



United Nations Environment Programme
Industry and Environment

UNEP IE

Cleaner Production in Leather Tanning

A Workbook for Trainers



UNEP

Cleaner Production in Leather Tanning

A Workbook for Trainers

First Edition • March 1996



UNEP

**UNITED NATIONS ENVIRONMENT PROGRAMME
INDUSTRY AND ENVIRONMENT**

39-43, QUAI ANDRE CITROEN
75739 PARIS CEDEX 15 - FRANCE

TEL : (33) 01 44 37 14 50

FAX : (33) 01 44 37 14 74

E-MAIL : unepie@unep.fr

<http://www.unepie.org/home.html>





Cleaner Production in Leather Tanning

A Workbook for Trainers

This package is one of a series that provides practical support material to teachers and trainers wishing to commence or enrich their curriculum with up-to-date approaches in environmental management.

It is based on extended experience with training workshops by UNEP and other agencies, and is now being made available for wider use in all regions throughout the world.

Acknowledgements

The first version of this trainers workbook was prepared in 1994 by F. Balkau and J.W. Scheijgrond for UNEP IE.

Further additions were made by the British Leather Confederation (BLC) under contract to UNEP.

It was subsequently trialled in workshops and courses in several places, leading to subsequent revisions to produce this current document.

UNEP would like to thank the many individuals and organizations who contributed ideas and materials, or who assisted in reviews and redrafting. Particular thanks go to Chizuru Aoki, Garrette Clark, John Kryger, and Sybren de Hoo in UNEP's Cleaner Production Programme, as well as Colin Sutherland, Bob Boland, Deborah Hanlon and Don Huisingsh. The staff of the Central Leather Research Institute, India, reviewed parts of the package and made helpful comments.

Copyright © UNEP 1996

All rights reserved. No part of this publication may be produced, stored in a retrieval system or transmitted in any form or any means: electronic, electrostatic, magnetic tape, mechanical, photocopying, recording or otherwise, without permission in writing from the copyright holder.

First edition March 1996

The designations employed and the presentation of the material in this publication do not imply the expression of any opinion whatsoever on the part of the United Nations Environment Programme concerning the legal status of any country, territory, city or area or of its authorities, or concerning delimitation of its frontiers or boundaries. Moreover, the views expressed do not necessarily represent the decision or the stated policy of the United Nations Environment Programme, nor does citing of trade names or commercial processes constitute endorsement.

United Nations Publication

ISBN 92-807-1606-9

Table of Contents

Cleaner Production in Leather Tanning

| | | |
|----------|---|--------|
| | Evaluation Form..... | i |
| | Users Guide | iii |
| Part I | Introduction | |
| | 1.1 This package..... | I:4 |
| | 1.2 Contents of this package..... | I:4 |
| Part II | Organizing Effective Training Activities | |
| | 2.1 Introduction..... | II:3 |
| | 2.2 Notes on interactive workshop organization..... | II:4 |
| | 2.3 Some ideas for more effective communication | II:5 |
| | 2.4 Some personal suggestions for effective training..... | II:6 |
| | 2.5 Resource persons guide..... | II:7 |
| | 2.6 Suggestions for self study..... | II:9 |
| Part III | Description of the Leather Tanning and Finishing Process | |
| | 3.1 Summary..... | III:3 |
| | 3.2 Introduction..... | III:3 |
| | 3.3 The manufacturing process..... | III:4 |
| | 3.4 Waste characterization and impacts..... | III:7 |
| Part IV | Beamhouse Processing | |
| | 4.1 Introduction..... | IV:3 |
| | 4.2 Materials audit | IV:4 |
| | 4.3 Cleaner production..... | IV:13 |
| Part V | Tanning Process | |
| | 5.1 A tanning case study..... | V:3 |
| | 5.2 Answers to the work exercises..... | V:17 |
| Part VI | Leather Finishing | |
| | 6.1 Introduction to leather finishing | VI:3 |
| | 6.2 Leather finishing case study..... | VI:13 |
| | 6.3 Answers to the work exercises..... | VI:28 |
| | 6.4 Examples of chemicals used in leather finishing..... | VI:37 |
| Part VII | References | |
| | 7.1 Introduction..... | VII:3 |
| | 7.2 References on leather tanning and finishing..... | VII:4 |
| | 7.3 Centres of expertise on leather..... | VII:5 |
| | 7.4 Background material on cleaner production..... | VII:6 |
| | 7.5 Transparencies on cleaner production | VII:14 |
| | Annexes | |
| | I <i>Process Guidance Notes on Leather Finishing</i> | 3 |
| | II <i>Examples of Health and Safety Data Sheets for Chemicals</i> | 17 |
| | Appendices | |
| | I <i>Supporting Documents for this Package</i> | 3 |
| | II <i>List of Training Resource Packages available from UNEP IE</i> | 5 |
| | III <i>About UNEP Industry and Environment</i> | 7 |

Users Guide

This is a trainers support package, *not* a reference book. It does not give a systematic, comprehensive overview (there is not enough room to do this); rather, it focuses on some selected aspects that are central to the subject. The structure of the document allows further sections to be easily developed and added as additional modules.

The package is written for trainers to provide them with support material and ideas, rather than as a study book for students. The average trainee will only ever see a few pages or exercises reproduced from this document.

One of the purposes of this package is to provide some case studies and situation scenarios that can be used as a basis for interactive training and simulated decision-making. However, the exercises only explore a small part of the potential of the case studies, and trainers are strongly encouraged to develop further exercises or tasks.

The package is oriented at developing insights and decision-making skills. For teaching the factual knowledge base of the subject, trainers are referred to the reading lists in the bibliography.

Work exercises are predominantly based on interactive groupwork and a team approach to

problem-solving. Such work needs to be guided by a tutor who is a recognized expert in the field. This method allows the full complexity of real decision-making to be explored.

Where calculations are required, the exercises are more oriented towards throwing light on useful approaches or management decisions than simply finding the 'correct' answer. Trainers are strongly urged not to see this package merely as a set of arithmetic exercises.

In some instances, answers are indicated. The 'correct' answer depends on the context of the question. It is here that a tutor or external resource expert is useful.

Many trainers find this disturbing. They should remember that real decision-making depends on the wider circumstances surrounding the problem, and that a numerical answer which is politically or socially unacceptable, or administratively unworkable (even though accurate), is not in effect 'correct'.

The simulation of real life situations and decision-making that is the basis of this package makes it most suitable for senior students and trainees, and especially for professional training (or retraining) courses.

Do not forget to also refer to the package on *Cleaner Production* for teaching the underlying concepts and approaches in this workbook.

Finally, we must stress again that this package does not cover all aspects of the subject. Its prime purpose is to lead trainers into this field, and to help and encourage them to develop their own material, appropriately tailored to their specific learning situation. UNEP is prepared to work further with trainers who wish to extend this package into new directions, or go into greater depths on some subjects.

How to start a training activity based on this package

1 *Remember that this is a starters kit*, not a complete recipe book. Remember also that the workbook aims to develop insights and decision-making skills, not to convey knowledge or facts.

2 *Understand the needs of your trainees*. What insights or skills do you intend to develop? Define your learning objectives.

3 *Refresh your memory* by reading some of the background papers and studying the overhead transparencies. Write your own notes in the spaces provided.

4 *Identify some expert resource persons* who could be invited as tutors to help you in discussion sessions.

5 *Select some of the exercises* you wish to present to trainees.

6 *Examine carefully the case study or scenario* on which they are based. Be sure that you have at least one solution to the exercise that you can explain and defend.

7 *Develop other exercises* or questions yourself.

8 *Develop your own local case study* if you can, and use this instead of the one in the package.

9 *Prepare some background questions* and preliminary exercises for trainers to carry out before they start the workshop/course.

10 *In session, summarize the issues* for trainees using the overheads given, and others you may have. Discuss the problems and difficulties decision-makers face. Discuss where factual information can be found to help in decision-making.

11 *Commence the work sessions*, preferably in small groups, and preferably guided by

a tutor. Discuss and compare results. Be open to ideas and experiences from trainees, and discuss these.

12 *Return to the learning objectives*, and check that they have been achieved.

13 *Consider how to follow up* and reinforce the learning experience by establishing some ongoing projects, or periodic reunions.

Refer also to other packages and workbooks, where useful additional teaching material is found.

To facilitate using this package, the header of odd-numbered pages describes the contents of that particular section. This information is also repeated in the footer of even-numbered pages. You can track your progress through the package by referring to the calibrations on the bar across the bottom of odd-numbered pages:



The shading shows your current position in the text.



Part 1

Introduction

| | |
|---|------------|
| <i>1.1 This package.....</i> | I:4 |
| <i>1.2 Contents of this package</i> | I:4 |

1 Introduction

Many teaching institutions and individual trainers have difficulty in following the rapid evolution of environmental issues that are relevant to their courses.

This is particularly true when teaching subjects such as pollution and environmental management. And yet it is important that new graduates have a good knowledge of issues in which they may eventually provide consulting services or policy advice to governments and industry.

The fact that development and environment are interrelated means that it is more vital than ever that:

- *all professionals have a basic environmental literacy that helps them to incorporate environmental priorities into their specialized work, whatever their profession;*
- *specialized environmental courses are relevant to today's environmental agenda.*

In 1993, in response to these findings, UNEP, WHO, and ILO jointly initiated the programme on Training Approaches for Environmental Management in Industry. The programme aims to enhance the capacity of national institutions to offer local training on topics concerned with the prevention of industrial pollution.

In this context, trainers' packages have been prepared on different areas of environmental management. These packages are intended to help educators and trainers to develop their own workshops or curricula, or to integrate some of the ideas and information into already existing teaching programmes.

It is important to keep in mind that these training resource packages merely provide a first orientation to the topic.

In no way does the package constitute a 'course' in its own right.

1.1 This package

This package is a workbook that complements the trainer's package on '*Cleaner Production*'. For best results, both should be used together. In many cases, it would be useful to use the Cleaner Production material as an introduction to any curriculum-based material in this workbook.

The workbook is balanced between curriculum-based content (useful for technicians) and a more management systems approach (useful for supervisors and managers). In practice, both will be needed, and the trainer is urged to develop a

balanced curriculum in response to the needs of his/her audience. Any missing elements may be found in one of the other UNEP manuals, to be converted into training format based on the case studies and scenario included here.

Thus, the package is not static.

As feedback is received from users and technical specialists, the material will be modified and enriched.

Users are encouraged to report on their experiences in using this package, and to send in suggestions for improvements.

1.2 Contents of this package

This package is conceived principally to help trainers prepare a seminar, workshop, or extended course. It is not a course per se.

The package contains:

- suggestions and hints for *effective training*;
- a *short background* to the subject, drawn from other existing publications;
- *overhead transparencies* to introduce and illustrate the main ideas;
- *case studies* and situation reports and scenarios drawn from actual experience;

- *work exercises* and questions;
- *annexes* containing supplementary technical information to support some work exercises;
- *appendices* with further information about UNEP and its programmes.

Trainers are encouraged to extend the package by adding their own case studies and exercises, and expanding the subject coverage into new topics. For example, trainers in environmental health may wish to add some modules on occupational safety and ecotoxicity by building on the chemical information already presented.



Part 2

Organizing Effective Training Activities

| | | |
|------------|--|-------------|
| 2.1 | Introduction | II:3 |
| 2.2 | Notes on interactive workshop organization..... | II:4 |
| 2.3 | Some ideas for more effective communication | II:5 |
| 2.4 | Some personal suggestions for effective training..... | II:6 |
| 2.5 | Resource persons guide..... | II:7 |
| 2.6 | Suggestions for self study..... | II:9 |

2 Organizing Effective Training Activities

2.1 Introduction

Communication and organizational skills are just as important as a technical appreciation of the subject. Professional educators already understand this point, but teaching is a very individual matter, and interactive teaching can be very demanding on a busy person.

Here, we recall some of the key aspects of the learning process.

This text contains suggestions about:

- *how to ensure maximum effectiveness as a trainer*
- *how to organize effective training activities and presentations.*

We have provided this advice before consideration of the technical material, so that readers can remind themselves of the importance of the advice when choosing work exercises and training projects, later in this package.

Adults learn best when they are actively engaged. They remember 20% of what they hear, 40% of what they see, and 80% of what they discover for themselves.

Accordingly, this package relies on interactive teaching methods, using working exercises, case studies, and groupwork problem-solving, rather than on lecture format.

Interactive techniques are more complex to organize than simple lecture-giving, but they give better results. In particular, interactive methods are more likely to provide students with practical skills. This is important where skill development rather than factual knowledge is the objective. Lectures are better at providing factual knowledge than at developing skills.

For example, a workshop format is very effective in providing training on the effective use of management tools such as *Environmental Impact Assessment (EIA)*, or audits. For high level environmental management, both knowledge and skills are required, so the appropriate mixture of techniques should be used.

The notes in this Part are based on the experiences of UNEP IE and WHO in organizing workshops and other training sessions.

Personal advice on how to be an effective trainer is also given by several experienced trainers, who all use interactive training approaches.

2.2 Notes on interactive workshop organization

2.2.1 Workshops

Workshops provide a stimulating learning environment where people with a wide range of experiences and skills can join together to address practical problems beyond the ability of an individual to resolve.

Interactive workshops use a combination of several techniques to bring about a deeper and more pragmatic learning experience than is possible with a lecture-style format.

Workshops also provide excellent opportunities for exchanging personal experiences, problem-solving through panel sessions and direct consultations with experts, and discussing some of the complex situations which surround most environmental problems.

The UNEP/WHO workshop format incorporates the following elements:

- sending out pre-workshop reading material, with some simple exercises

- preparation of a country report by each participant before the workshop
- short introductory or overview lectures on key issues
- practical problem-solving work exercises on case studies
- feedback by experts and discussions on workshop exercises
- panel sessions (that is, question-answer dialogues) with experts
- individual study sessions, computer quizzes, and so on.
- structured oral presentations of country reports leading to a regional overview
- audiovisuals such as videos, films, and slides
- field visits where appropriate
- personal action planning by participants for follow-up activity.

2.2.2 Preparation

Sessions need to be carefully prepared, with participants knowing in advance what they will do or see. A proforma report form for country reports gives a common format to these sessions. Country reports should also try to link the issues with other sessions.

It cannot be overstressed how important it is that participants should be thoroughly prepared for the workshops, and that all the pre-workshop activities have been completed.

2.2.3 Organization

The organization of working group sessions also requires care. Groups should first meet informally, elect their own chairman, and then act as a permanent team in various workshop sessions. They are guided, but not instructed, by technical experts.

It is useful to finish the workshop by preparing personal action plans. Participants should develop and present their proposals for what they can initiate immediately on their return home. Such action includes:

- what they can achieve unassisted, *and*
- what else they could achieve if some assistance were available.

The role of resource experts as advisors is crucial. They should have sufficient experience to assist in all sessions and provide general advice on all subjects in workshops, discussion or panel sessions. They should not, however, dominate the workshops.

The five day format is ideal for covering all these requirements. If less than five days is taken, you can be sure that important issues will be left out. If more time is available, consider including social events and private study sessions, along with more extensive project work for the students.

2.3 Some ideas for more effective communication

If the training is to be successful, effective communication is essential – from recognition of the training need to the final evaluation of the event.

Without good communication, all manner of things can go wrong:

- the training is too early – or too late – to make any impact on performance
- trainees do not know what the training is about or what to expect
- the course is planned for a local public holiday

- trainees who are traditionally used to lectures are suddenly required to take part in discussion groups, which might feel alien to them.

Most of these issues can be anticipated and overcome by good communication between the course designers, writers, and event organizers and presenters on the one side, and the students and their organizations on the other.

Some simple communication considerations will help to improve outputs in training and avoid disasters.

Before the learning event

Find out:

- how the learners have been taught in the past
- the real needs and situation of the learners
- whether the facilities are adequate for the envisaged training
- whether the training has the support of senior people
- how success will be measured.

Make a project plan for the organizers, giving details of how the event will be organized. Send the plan to them, with details of the key dates and needs.

During the learning

- find out how relevant the topics are to the work situation of the participants
- start with the familiar oil can – not a video of an oil spill disaster
- communicate using topics, themes and issues in the local press
- store unanswered questions, and remember to answer them before the end
- keep notes for participants to bullet-point format
- ensure the participants keep notes for future reference – few read essays, or even articles
- if you are working in a foreign language, at least translate the slides.

After the learning event

- always communicate your thanks and best wishes
- inform participants on follow-up study procedures, and how the instructor can help to analyze the evaluations and inform the organizers of the results
- communicate to colleagues the results of the training and what can be learned from these results.

2.4 Some personal suggestions for effective training

The following suggestions come from four teachers with long experience in training. They are all different in character, and therefore in teaching approaches. However, they all believe in an enthusiasm for the subject which is critical when teaching students.

To be an effective educator/teacher:

- Provide an enjoyable learning situation that expands all of the participants' network.
- Model courses and teaching styles on examples that you think are outstanding. Ask yourself about the qualities of a good instructor or a good course, and follow the answers you come up with.
- Allow the subject matter to be discussed and discovered by students – not hammered in.
- Make courses relevant and interesting by understanding your audience. Ask them what they already know, and then plan for their needs. Incorporate ideas from the group in the course.
- Remember that no amount of style will substitute for a lack of substance.

Deborah Hanlon, Environmental Scientist
Office of Environmental Engineering
and Technology Demonstration, US EPA

The outstanding educator/teacher:

- Is fully acquainted with, and believes in, the educational merit of the subject matter.
- Utilizes clear and graphic illustrations to inform and motivate the students to learn.
- Utilizes learning approaches including multimedia, projects, interviews, questionnaires, debates, and similar interactive approaches to ensure full involvement of the students.
- Reacts positively to all questions – there are no Stupid Questions, only Stupid Answers.
- Remembers that positive reinforcement is a better motivational approach than criticism.
- Is available for private discussions with individual students or groups of students.

Don Huisingh, Environmental Consultant and Professor at
Erasmus University in Rotterdam
the Netherlands

To be efficient ('doing things right'), and effective ('doing the right things'):

- Think about helping people to learn, rather than teaching them.
- Seek learner feedback, and measure learning achieved with objective tests.
- Set learning time limits.
- Seek conscious and unconscious learning.
- Seek learning that endures, based on understanding and skills.

Bob Boland, Environmental Consultant, France

The best educator/teacher:

- Likes the learners, and has a true understanding of how they learn.
- Has the ability to communicate.
- Will change the training programme and the approach if necessary.
- Is still learning, and has recent applied experience of the subject being taught.
- Has the ability to organise events and to manage things.

Colin Sutherland, Educational Consultant, France

2.5 Resource persons guide

As this package relies heavily on interactive groupwork sessions, here are some guidelines on how to be an effective resource person.

In a case study-based training approach, the resource person serves more as a:

- facilitator of the group learning process
- technical adviser as needed,
and a
- catalyst of learning
rather than a:
 - lecturer
 - story-teller
- or*
- instructor.

Here are some guidelines on how to be an effective resource person.

1 Be sure that you have *read and understood thoroughly* the participant's notes before you meet your group. There's nothing like being prepared and more familiar with the case study scenario than the participants are!

2 Before every group work session, take time to visit your assigned meeting room and check the:

- **seating arrangements** There should be a large enough table surrounded by enough chairs for the participants and yourself
- **equipment and supplies** such as flipcharts, flipchart papers, marker pens, white/black board, board eraser, masking tape, transparency sheets, writing pads, ballpen/pencils, calculator, etc.
- **physical conditions of the room** There should be sufficient lighting, the room temperature should be comfortable, noise should be as low as possible, etc.

3 During the initial group meeting, it is important to set an *informal and friendly atmosphere*. It is suggested that you:

- **introduce yourself**, preferably asking everyone to call you by your first name, and then let everybody introduce himself/herself in a similar manner. *Do not waste time stating positions*

and respective organizations, etc., which should have been done on the first day anyway.

- then ask if the *objectives and purpose* of the exercise, which have been previously discussed in the plenary session, are clear to them.

Sample objectives are:

- identify and understand the options that SMEs can employ in their pollution prevention program
- evaluate the feasibility and suitability of these options in view of technical, environmental, financial, organizational, and social criteria and constraints.

It will be useful to know whether the majority of the group members have actually read the text provided, which states the background and the problem.

If they have not, then you will need to direct them to focus their attention first on what needs to be accomplished by the end of each part.

4 If your group gets involved in diverse issues, try to steer them back on the right track by *asking relevant questions*, rather than telling them what to do.

5 Give *technical assistance and supplementary information* as needed,

without 'spoon-feeding' the participants. However, do not lecture or dominate the group discussion process.

- 6** Although you need not stay with your group for 100% of the time, it is expected that you:
- *spend at least 80% of the time* with them during regular sessions. The crucial times are at the *beginning, middle*, and near the *end* of each groupwork session.
 - If they decide to work beyond the prescribed regular time, just make sure that they are on the right track; your presence during overtime is not mandatory, but voluntary.

7 There will be *critical parts* during the identification of options, followed by technical, environmental, and economic evaluation, where your technical advice will be most needed by your group.

The best way to assist the participants is by giving only the advantages and disadvantages of the options in question. Let them weigh these pros and cons and decide for themselves whether to take or drop the option.

8 If you encounter any question about the technical content of the material that you have not been briefed on, discuss it with the Team Leader and *agree on how to tackle the situation*. It may well be that the other resource

persons need to be duly advised on the particular question.

9 See to it that you *compare notes, exchange hints, and share strategies* with other resource persons so that you can assist one another, as well as gauge your group's progress in comparison with the others.

10 If tension or heated argument arises among your group members, try your best (with a sense of humor) to *defuse* it.

11 In the case of *absenteeism*, approach the person/persons in question and encourage them to participate.

12 If one or two group members are dominating the discussions or doing all the work, intervene and *encourage everyone to get involved*. In order to do this effectively, you need to be attuned to your group's 'culture' and trend of discussion.

13 Although *division of labor* is a time saving group work strategy, you must ensure that it is not done to the extent that there is no peer learning and discussion occurring. It is counter-productive for group members to work individually on these exercises.

14 The most productive, meaningful and fulfilling group work is when they get to accomplish what they have to do *as a team* – and have fun in the process!

2.6 Suggestions for self study

Although this package was designed to provide resources for trainers, the potential for self-study should not be ignored.

The package does not constitute a complete course on cleaner production in leather tanning, but can be seen as an introduction to be

supplemented by further reading and additional training materials listed in the Appendices, and perhaps by site visits and discussions with professionals.

The following approach is suggested for individual study.

- Read the *introduction*, but avoid any sections on organizing training events.
- Seek out the section containing *background papers* or *subject content*. Read through the whole section as narrative.
- Work through the pages offered to the trainer for *overhead projection*, and ensure you can relate the key points of each overhead to the text you have read.
- Look at the section on *exercises*. Identify those which lend themselves to individual work, and tackle them. Those exercises clearly constructed for teamwork, or requiring research, may not be appropriate.
- Refer back to the *narrative* text as and when you need to, to complete the exercises.
- Check your *answers* against those given in this resource pack. Where there are discrepancies, check through your own working to understand why the discrepancies appeared.
- Use the *Appendices* to plan your own further development.



Part 3

**Description of the
Leather Tanning and
Finishing Process**

| | |
|--|--------------|
| 3.1 Summary | III:3 |
| 3.2 Introduction | III:3 |
| 3.3 The manufacturing process | III:4 |
| 3.4 Waste characterization and impacts..... | III:7 |

3 Description of the Leather Tanning and Finishing Process

This part contains a short description of the leather tanning and finishing process. Material has been taken from unpublished reports prepared by the World Bank, the United Nations Industrial Development Organization (UNIDO), and the United Nations Environment Programme (UNEP). A more comprehensive description can be found by consulting the references listed in *Part VII* of this workbook.

3.1 Summary

The processing and preservation of animal hides and skins to make leather is one of the oldest industries in history and is highly versatile, producing a product for a wide variety of uses.

The tanning process is usually accomplished in three distinct phases:

1 the preparation of the hides (in a beamhouse)

2 the actual tanning to make leather (in the tanyard)

3 finishing the leather (in the post-tanning area).

For each of the three processes, technologies for relatively efficient use of material and process modification are available to minimize the wastes.

Waste minimization and process changes – i.e. the use of the cleaner production approach – are more cost effective than end-of-pipe waste treatment; therefore, cleaner production technologies and procedures should be the **first** goal in pollution control, and adoption of *effluent discharge standards* should be the **second**.

3.2 Introduction

During the tanning process, animal hides and skins are treated to remove non-structured proteins and fat, leaving an essentially pure collagen matrix that is preserved by tanning. This involves the impregnation of the skins with mineral, synthetic or vegetable tanning agents.

Small plants processing as few as a dozen hides a day can be economically viable if they are situated close to sources of hides, water and energy.

The potential environmental impacts of tanning can be significant. The industry produces toxic gases (hydrogen sulphide and solvent vapours), putrefying solid waste, and copious volumes of wastewater containing high concentrations of inorganic salts, heavy metals and organic substances in solution or suspension.

A wide range of technology options exists for waste minimization and the treatment of tannery wastes.

3.3 The manufacturing process

The conversion of cattle hides to leather accounts for the bulk of the tanning industry and is described here to illustrate the tanning process (see *Figure 3.1*).

Significant differences occur in the processing of pig, goat and sheep skins, and these variations are identified where appropriate.

3.3.1 Beamhouse processing

The following steps occur in cattle hide tanneries.

- Incoming hides are soaked in water for 16–24 hours to remove blood, dirt and salt, and to hydrate dried hides. The hides may be soaked in pits or rotating drums in which the water is changed frequently. During the next stage, the hides are immersed in a lime and sodium sulphide solution for 12–18 hours to loosen and

remove the hair. The hair may either be removed mechanically or by pulping in a drum.

- During the next step, the hides are treated with lime to open up the collagen structure by removing interstitial material. After liming, the hides are scraped mechanically to strip excess flesh from the underside.

3.3.2 Tanyard processing

The first steps in the tanyard are deliming and bating. The hides are typically treated with ammonium sulphate or ammonium chloride to remove the lime. Following this, hides may be bated using a protein-digesting enzyme solution to break down any unwanted protein.

Two tanning processes may be used for cattle hides, pigskins or sheepskins:

Chrome tanning

A tanning solution of (trivalent) chromium salts is used. Hides are pre-treated, usually in revolving wooden drums, by 'pickling' in salt and sulphuric acid for several hours to prevent subsequent precipitation of chromium salts.

Chromium salts are then added, and after several hours, the chromium is fixed into the hides by increasing the pH of the solution by means of adding an alkali such as sodium carbonate. The exhausted chrome liquor is then discharged as wastewater or recycled.

Processed hides are stored for 24 hours for further absorption and fixing. They either remain

on site or are transported to another location (as 'wet-blue') for post-tan processing such as dyeing and fat liquoring.

Vegetable tanning

A tanning solution is prepared from bark, wood, fruits, pods or roots that contain tannin.

Hides are submerged over a period of three weeks to six months (depending on the type of leather required) in a series of pits containing vegetable tanning solutions of increasing strength. The weakest solution is usually discharged daily as wastewater.

Vegetable tanning of sheepskins is uncommon.

A wide range of alternative tanning materials is available for the primary tan or for complementary tanning. These include synthetic tans, aluminium, titanium and zirconium, salts and aldehydes; cod oil is used in the production of chamois leather.

Aluminium is unsuitable as a primary tan since it is not sufficiently resistant to water and perspiration. Titanium and zirconium tanned leathers would not be suitable for modern shoemaking processes.

Figure 3.1

Process diagram of tanning and finishing

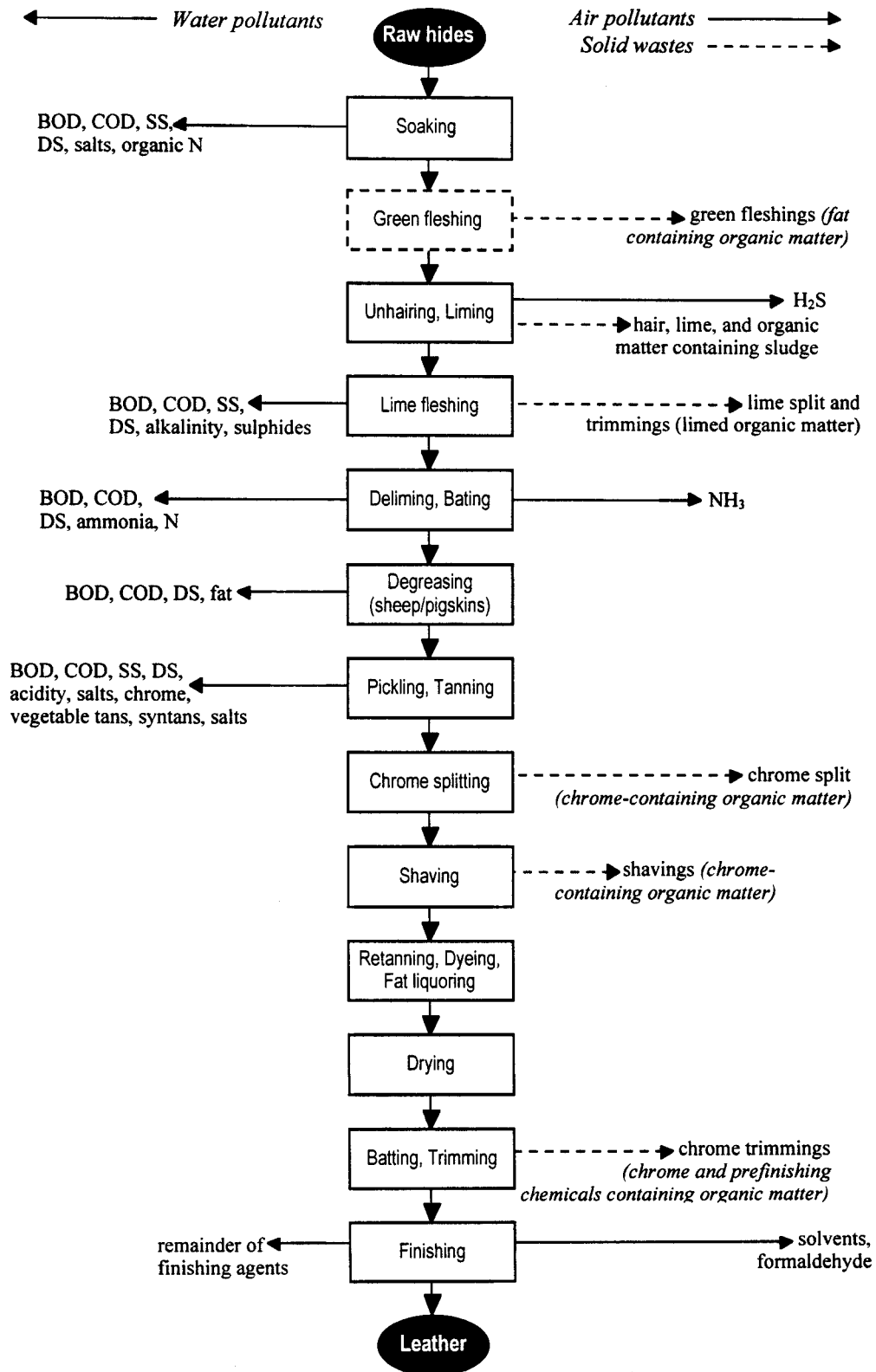

3.3.3 Post-tan processing

To produce finished leather, the hides must pass through a series of post-tan processes, which may include *retanning*, *dyeing* and *fat-liquoring*.

Retanning modifies the characteristics of the leather (such as texture). The retanning of pigskins is generally uncommon. The hides also may be immersed in *dye* to obtain coloured leather.

During *fat-liquoring*, the tanned leather is treated with preparations of natural and/or synthetic oils to replace the natural oils lost during processing.

After post-tan processing, the hides are dried and pressed; to create the correct shape and surface texture, they may also be trimmed, split, shaved and buffed. A decorative and protective surface coating may also be applied (the 'finishing' process).

3.4 Waste characterization and impacts

Waste materials come directly from the hides and skins themselves and also from chemicals added during various stages in the tanning process. The volume and composition of the wastes produced varies according to the nature of the process, individual plant operations, and the skins and hides used.

3.4.1 Solid waste

Large quantities of hair, flesh, blood clots and dirt are generated during soaking, de-hairing, liming and fleshing, though the quantity will depend on the animal species and breed, and on slaughterhouse practices.

Generally, only 20% of the raw material used is transformed into the final product.

Very often the raw hides are made more amenable to handling by trimming off irregularities. Sludges can be produced during the treatment of the mixed effluent streams and of the separated effluent streams from liming and tanning. Dust may arise from the buffing operation or in the form of fly ash or crystallized salt

Table 3.1
Typical quantities of solid waste produced in leather tanning

| Component | Amount of waste (kg) per 1000kg wet, salted hide |
|----------------------------|--|
| Trimmings | 120 |
| Fleshings | 70-230 |
| Chrome shavings | 99 |
| Chrome split waste | 115 |
| Buffing dust | 2 |
| Finished trimmings | 32 |
| Solids in treatment sludge | 120 |
| Total | 688-848 |

Source: UK DOE 1977



Part 4

Beamhouse Processing

| | |
|------------------------------------|--------------|
| 4.1 Introduction | IV:3 |
| 4.2 Materials audit..... | IV:4 |
| 4.3 Cleaner production..... | IV:13 |

4 Beamhouse Processing

4.1 Introduction

Fresh hides have to undergo preliminary treatment (*curing*) before they can be transported to the tannery.

Although the skin of a living animal is protected against putrefaction (rotting), from the moment of slaughter, the protection ceases and bacterial action may set in, causing a breakdown of the skin. This putrefaction is commonly prevented by sprinkling salt onto the flesh side of each hide; the salt absorbs the water from the skin, and this brine then penetrates the hides, discouraging bacteria. This method of

preservation can be compared to the way in which salt was used to cure meat before refrigeration had been invented. The amount of salt used is around 25% of the raw hide weight. In this wet-salted state, the hides are stable and can be transported to the tannery.

Before actual tanning can commence, the hides or skins must undergo some further pre-treatment processes. These processes are associated with high water consumption and considerable environmental pollution, and are carried out in the 'beamhouse'.

The following exercises are based on a fictitious medium-sized tannery. They follow the processing of raw hides through to the point where they are ready for tanning. The hides are imported from another country.

The beamhouse which will prepare the hides has a number of wooden drums enabling the batch treatment of 40 tonnes of rawhide per day.

Beamhouse processing involves a range of chemicals, the prices of which can vary considerably from country to country. Typical costs for a selection of chemicals are as follows:

| Chemical | Cost (\$/tonne) |
|----------------------|-----------------|
| Salt | 120 |
| Sodium sulphide | 545 |
| Lime | 125 |
| Sodium hydrosulphide | 240 |
| Calcium hypochlorite | 50 |
| Ammonium sulphate | 315 |

4.2 Materials audit

The first series of exercises will consider materials audits of the processes by establishing the flow of materials to be managed.

Subsequently, the information will be used to investigate the different options for reducing material losses in the plant, leading to reduced

wastage and lower levels of pollution i.e. cleaner production.

In this section, we will consider the materials balance for the following processes:

- *soaking*
- *unhairing and liming*
- *fleshing and splitting*
- *deliming, bating and pickling.*

4.2.1 Soaking

The principal purpose of soaking is to rehydrate the hides ready for subsequent processing, and to remove the salt. In addition, this soaking in water removes dirt, dung and blood, and facilitates the removal of non-structural (non-collagenous) proteins, which would otherwise cause the tanned leather to be stiff.

The hides undergo two separate ten minute 'dirt soaks' to remove the majority of external contamination, followed by the main four-hour soak.

Each individual soak uses a 200% float (float being the liquor), expressed as per weight of hides processed.

After washing out the salt, the hides are once again extremely vulnerable to putrefaction, and so a biocide has to be added.

In addition, surfactants (wetting agents) are added to help dissolve dung and dirt, and soaking enzymes are added to aid the degradation.

Overall, the soaking process removes and washes out the following quantities of pollutants:

| | |
|---------------|---------|
| Solids | 7400 kg |
| COD | 1600 kg |
| BOD | 400 kg |

These quantities represent 44%, 30% and 23% respectively of the cumulative amounts discharged from the entire beamhouse process.



1 (i) What volume of effluent is produced from soaking?

(ii) What is the solids loading of the combined soak liquor effluent?

mg/l

(iii) What is the COD of the soak liquor effluent?

mg/l

Answers to this question are on page IV:10



2 Supposing all the added salt is removed from the hides during soaking:

(i) What quantity will the effluent contain?

(ii) What will its approximate concentration be?

Answers to this question are on page IV:10

3 Read through the *curing* and *soaking* stages:

(i) Of the above pollutants, what should we be able to avoid by introducing a process of change?

(ii) Suggest an alternative process (the text holds a clue):

(iii) How might the total water usage for soaking be reduced?

(iv) What would the new volume be?

(v) Are there any disadvantages to this?

Answers to this question are on page IV:10

4.2.2 Unhairing and liming

Having removed much of the external contamination together with some of the non structural proteins, the rehydrated and softened hides are ready for unhairing and liming. This stage removes the hair and epidermis, and further reduces the content of non-structural (inter-fibrillary) proteins.

At this particular plant, the hides (nominal weight 40 tonnes) are treated with 3% sodium sulphide (containing 25% sulphide) and 2% hydrated lime (calcium hydroxide) in a 200% float.

Drumming is carried out for 18 hours, during which time the sulphide breaks down (pulses) the keratin-based structures (hair and epidermis). The purpose of the hydrated lime is to buffer the float to a high pH (12.8-13.0), which causes the hides to swell, opening up the collagen fibre network and thereby softening the hide and facilitating the removal of the non-structural proteins. The hides absorb approximately 1% of their own weight in calcium hydroxide. In order to act as a buffer, the lime is added in excess, having a solubility of only 1.6g per litre at the liming temperature used.

This stage is completed in the form of two separate ten minute washes, each using a 250% float with 5% salt to prevent over-swelling of the already swollen hides.

Effluent analysis of the spent (combined) liquors showed that a further 44% of the beamhouse solids are removed at this stage, together with a further 65% of the total COD and 70% of the total BOD. A significant proportion of this organic pollution is derived from the degraded keratin comprising the hair and epidermis.



- 4 (i) What is the total volume of effluent produced from the unhairing and liming stage?

- (ii) What quantity of calcium hydroxide (lime) has been added?

Answers to this question are on page IV:10

- 5 How much of the calcium hydroxide can be expected to be present in the spent lime liquor as inorganic solids?

The answer to this question is on page IV:10

- 6 (i) What quantity of salt will the effluent contain?

- (ii) What other major pollutant is present, and in what quantity?

Answers to this question are on page IV:10

4.2.3 Fleshing and splitting

The flesh side of the hides still have excess fat, flesh and connective tissue attached, which must now be removed prior to further drum processing. The hides are individually fed through a fleshing machine consisting of a set of revolving cylinders designed to cut and scrape away the unwanted material. As the fleshed hides exit the rear of the through-feed machine, some of the rough edges are cut off, producing further waste in the form of limed trimmings.

The beamhouse manager has estimated that 15% of the raw hide weight comprises fleshings, whilst a further 12% is lost as limed trimmings.

The swollen, fleshed hides are in an appropriate state for splitting into two layers, to give a 'grain split' and a 'flesh split'. Unlike the original hide, the grain split is now of uniform thickness, and undergoes further processing to produce leather.

The uneven flesh splits are sold to a pet food manufacturer.

From the original 40 tonnes of raw salted hide, the beamhouse manager now has 20 tonnes of limed grain splits for further processing, and subsequent water and chemical quantities are calculated on this weight.



7 What mass of solid waste is produced at the fleshing stage?

The answer to this question is on page IV:10

4.2.4 Deliming, bating and pickling

The lime in the hides is no longer required, and must be removed before chrome tanning, which occurs in acidic solution. Reduction in the pH of the hides, which returns them to their natural thickness, is carried out in two separate stages, the first being referred to as deliming. Bating is carried out as part of the same process (in the delime float), and uses enzymes to digest and dissolve some of the remaining non structural proteins.

At this tannery, deliming is carried out using 2% by weight of ammonium sulphate in a 100% float. The ammonium sulphate ($27.3\% \text{NH}_4^+$) acts as a weak acid, buffering the float and hides to a pH of approximately 9.0, and gently reducing the thickness of the hides. At the same time, the calcium salts and sulphide are washed out of the skin; it is essential that these are removed before the pH is reduced further. Sulphide ions absorbed in the hides would be liberated to form toxic hydrogen sulphide gas in acidic conditions, and the calcium ions could be precipitated as insoluble calcium sulphate, subsequently ruining the quality of the leather.

Following deliming and bating, the float is drained and the hides are washed in a 300% float

with 5% salt; the salt prevents the hides from absorbing water and suddenly swelling again.

The beamhouse manager has ascertained that the deliming and bating stage frees the hide of the remaining complement of organic solids, COD and BOD discharged from the entire beamhouse process.

Tanning (not covered by this module) occurs at a pH of less than 4. Deliming has brought the hides down to a pH of 9, so they must be prepared for tanning by pickling, which brings about the second stage of their pH adjustment.

Pickling utilizes a 100% float containing formic and sulphuric acids. Salt must again be added (to 8% of hide weight) in order to prevent acid swelling and the damage that would ensue.



8 What volume of effluent arises from the deliming and pickling stage?

Answers to this question are on page IV:10

9 Only 50% of the ammoniacal nitrogen (ammonium salt) added to the limed hides is eventually discharged in the beamhouse effluent, with none being taken up by the hides.

(i) What mass is discharged in the effluent?

(ii) What happens to the remainder? Is this a problem? (*Hint: the ammonium salt behaves as a weak acid, losing a proton in alkaline solution:*)

Answers to this question are on page IV:10

10 Only 50% of the ammoniacal nitrogen (ammonium salt) added to the limed hides is eventually discharged in the beamhouse effluent, with none being taken up by the hides.

(i) What mass is discharged in the effluent?

(ii) What happens to the remainder? Is this a problem?

(*Hint: the ammonium salt behaves as a weak acid, losing a proton in alkaline solution.*)

Note to the trainer: You may wish to develop additional exercises and questions based on the data given here.

Answers to this question are on page IV:11

4.2.5 The overall materials audit for beamhouse processing



- 11 *i)* What is the total volume of effluent produced in the beamhouse per tonne of salted raw hide processed?

| |
|--|
| |
|--|

- (ii)* For the table below, fill in the individual and total masses for organic solids, COD and BOD pollution resulting from the hides during beamhouse processing. You will need to refer to each individual section for this part of the audit:

| | Solids | | COD | | BOD | |
|-----------------------------|--------|---------|-----|---------|-----|---------|
| | % | mass/kg | % | mass/kg | % | mass/kg |
| <i>Soaking</i> | | | | | | |
| <i>Unhairing and liming</i> | | | | | | |
| <i>Deliming</i> | | | | | | |
| Total | | | | | | |

- (iii)* Finally, an audit summary. For one tonne of rawhide processed in the beamhouse, list the total quantity of each individual discharge:

| | |
|--|--|
| <i>Effluent</i> | |
| <i>Lime (total)</i> | |
| <i>Solids (organic)</i> | |
| <i>COD</i> | |
| <i>BOD</i> | |
| <i>Salt</i> | |
| <i>Sulphide</i> | |
| <i>Fleshings</i> | |
| <i>Trimnings</i> | |
| <i>Ammoniacal nitrogen in effluent</i> | |
| <i>Gaseous ammonia</i> | |

Answers to this question are on page IV:11

4.2.6 Answers to the materials audit work exercises

Soaking

Question 1 page vi:4

- (i) The volume of effluent produced from soaking is $40 \times 3 \times 200\%$ 240m^3
 (ii) The solids loading of the combined soak liquor effluent is
 $7400\text{kg} + 240\text{m}^3$ $30\ 833\text{mg/l}$
 (iii) The COD of the soak liquor effluent is $1600\ \text{kg} + 240\ \text{m}^3$ $6\ 667\text{mg/l}$

Question 2 page vi:5

- (i) If all the added salt is removed from the hides during soaking, the quantity of salt contained by the effluent is 25% of $40\ \text{tonnes}$ $10\ 000\text{kg}$
 (ii) Its approximate concentration will be $10\ 000\text{kg}$ in 240m^3 $41\ 667\text{mg/l}$

Question 3 page vi:5

- (i) Salt.
 (ii) Refrigeration would eliminate the use and subsequent discharge of 10 tonnes of salt.
 (iii), (iv), (v) The answer will be given in the Cleaner Production stage.

Unhairing and liming

Question 4 page vi:6

- (i) The total amount of effluent produced from the unhairing and liming stage is:
 $200\% \text{ float} + 250\% \text{ float} + 250\% \text{ float} = 80\text{m}^3 + 100\text{m}^3 + 100\text{m}^3 = 280\text{m}^3$
 (ii) The quantity of lime added is equal to 2% on raw hide weight:
 $0.02 \times 40\ \text{tonnes} = 800\text{kg}$

Question 5 page vi:6

Of the 800kg of calcium hydroxide added, the hides absorb $40\ 000 \times 1.0\% = 400\text{kg}$
 The solubility is 1.6g/l, therefore $80\ 000 \times 1.6\text{g} = 128\text{kg}$ is *dissolved*.
 This leaves $800 - 400 - 128 = 272\text{kg}$ calcium hydroxide undissolved as inorganic solids in the spent lime liquor (34% of the offer).

Question 6 page vi:6

- (i) The salt contained by the effluent is equal to $0.05 \times 40 \times 2 = 4\ \text{tonnes}$.
 (ii) Sulphide is the other major pollutant, with a quantity of:
 $40\ 000\text{kg} \times 0.03 \times 0.25 = 300\text{kg}$

Fleshing and splitting

Question 7 page vi:7

Fleshings $40\ 000\text{kg} \times 0.15$ $6\ 000\text{kg}$
 Trimmings $40\ 000\text{kg} \times 0.12$ $4\ 800\text{kg}$
Total solid waste = 10 800kg

Deliming, bating and pickling

Question 8 page vi:8

The volume of effluent arising from the deliming and pickling stage is:
 $20 \times 100\% + 20 \times 300\% + 20 \times 100\% = 100\text{m}^3$

Question 9 page vi:8

- (i) Offer of ammonium sulphate is 2% of hide weight = $0.02 \times 20\ 000\text{kg}$ 400kg
 Of this, 27% is ammoniacal nitrogen = $0.27 \times 400\text{kg}$ 108kg of NH_4^+
 Of this, 50% is discharged to effluent 54kg

Question 9 *continued*

(ii) Ammonium sulphate undergoes the following reaction with calcium hydroxide:

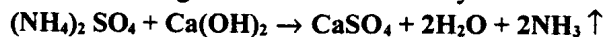

The remaining 50% of the ammoniacal nitrogen is thus liberated to the atmosphere as ammonia gas. This is hazardous, and may present a health and safety risk.

Question 10 *page vi:8*

(i) The hazardous lime liquor pollutant is a very toxic hydrogen sulphide gas.

(ii) In the absence of a special pretreatment of the spent lime liquor before mixing with the spent tanning liquor, very toxic hydrogen sulphide gas is liberated by the following reaction:

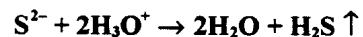

The overall materials audit for beamhouse processing

Question 11 *page vi:9*

(i) For 40 tonnes, effluent volume is as follows:

| | |
|---------------------------------------|--|
| Soaking | 240m ³ |
| Unhairing and liming | 280m ³ |
| Delimiting, bating and pickling | 100m ³ |
| Total | 620m ³ |
| | 15.5m ³ per tonne of raw hide |

(ii) We are given the percentages discharged from soaking and liming processes, and are told that the delimiting process yields the remainder.

By difference, therefore, the delimiting stage yields the following:

Solids: 12%, COD: 5%, BOD: 7%

Now, from the soaking figures, dividing the given mass of each pollutant by its percentage gives the mass relating to 1%.

Multiplying this figure by the individual percentage figures for liming and delimiting gives the masses discharged for the three pollutants.

The figures are tabulated below, with the calculated masses in brackets.

| | Solids | | COD | | BOD | |
|-----------------------------|--------|----------|-----|---------|-----|---------|
| | % | mass/kg | % | mass/kg | % | mass/kg |
| Soaking | 44 | 7 400 | 30 | 1 600 | 23 | 400 |
| Unhairing and liming | 44 | (7 400) | 65 | (3 467) | 70 | (1 217) |
| Delimiting | (12) | (2 018) | (5) | (266) | (7) | (122) |
| Total | 100 | (16 818) | 100 | (5 333) | 100 | (1 739) |

The overall materials audit for beamhouse processing continued

Question 11 continued

(iii) For one tonne of rawhide processed in the beamhouse, the total quantities of each individual discharge are as follows:

| | | |
|--|---|--|
| Effluent | 15.5m ³ | from question 11(i) |
| Lime (total) | 20kg | from question 4(ii) |
| Solids (organic) | 420.5kg | from question 11(i) |
| COD | 133.3kg | |
| BOD | 43.5kg | from question 11(i) |
| Salt | 250kg + 100kg + 20 000 x 0.05 + 40 + 20 000 x 0.05 + 40 = 415kg | from question 2(ii) from question 6(i) delime wash pickling |
| Sulphide | 7.5kg | from question 6(ii) |
| Fleshings | 150kg | |
| Trimnings | 120kg | from question 7 |
| Ammoniacal nitrogen in effluent | 54kg | from question 9(i) |
| Gaseous ammonia | 54kg | from question 9(i) |

4.3 Cleaner production

Increasing environmental pressures have forced the tannery management to devise a system of cleaner production within the beamhouse.

This series of exercises will be used to investigate the different options available in the beamhouse to reduce material losses and wastage in order to reduce pollution levels.

In this section, we will consider the materials balance for the following processes:

- *Raw material preservation*
- *Unhairing and liming*
- *Splitting*
- *Deliming bating and pickling*

These will be followed by an overall pollution summary.

4.3.1 Raw material preservation

The audit of the original process has shown that a total of 415kg of salt is used in the processing of one tonne of salted raw hides, and the management therefore decide to start by addressing this problem. A local abattoir with chilling facilities is located, and freshly chilled hides are transported to the tannery in refrigerated lorries. The hides are processed immediately.

Soaking

For each dirt soak and the main soak, the same volumes are used as previously.

However, it has been identified that the majority of external contamination is removed during the two dirt soaks.

It is therefore decided that the main soak liquor should be recycled, using the spent liquor for

one of the subsequent dirt soaks in the next batch of rawstock.

Green fleshing

To enable a cleaner unhairing and liming process, the hides are now fleshed directly after soaking.

The same quantity of fleshing results.



12 (i) What is the economic value of the salt saved per day?

(ii) Chilling has the important environmental benefit of eliminating salt from the spent (used) soak liquors. What disadvantages might be associated with this preservation technique?

(iii) Refer to *Section 4.2.1: Soaking*, on page VI:4. By recycling the main soak liquor, what reduction in water consumption is achieved?

(iv) What disadvantage might be associated with recycling the soak liquor?

(v) How might this be inhibited?

Answers to this question are on page IV:20



Supplementary Question

Hides may also be preserved using bactericides.

(i) What are some of the substances employed?

(ii) What are some consequences of using bactericides?

(iii) Where can you find further information on this technique?

(iv) Where can you find further information on the toxicity of bactericides?

4.3.2 Unhairing and liming

The unhairing and liming stage has been shown to be the major contributor to pollution in the beamhouse, removing the epidermis and hair by breaking them down to produce effluent pollutants (COD and BOD). 'Hair save' processing is a cleaner production method which manipulates the conditions of alkalinity and the reducing agent in such a way that the hair comes out of its hair follicle without being pulped. As the hair is not broken down, the suspended solids and BOD loading in the effluent is reduced.

Following small scale trials, it is decided to adopt a variation of the well-documented 'Sirolime' hair save process developed in Australia. This is a multistage process, to be implemented as follows.

Impregnation stage

The hides are drummed with 1% sodium hydrosulphide flake (containing 40% sulphide) in a 30% float for two hours, after which they are rapidly drained and washed in a 40% float (water only).

Hair protection stage

The aim is to remove the 'free' hydrosulphide associated externally with the hair and hide in the drum, leaving a sufficient concentration within the hair follicles so that the hair loosens when the hydrosulphide is 'activated' at a subsequent stage, but ensuring that the hair fibres themselves are not attacked.

The hides are drummed for 10 minutes in a 30% float containing the reducing agent (calcium hypochlorite) at a 2.5% offer.

Hair loosening and unhairing

The hydrosulphide within the follicles is 'activated' by adding lime to the existing float to 1% hide weight. After half an hour, water is added to increase the float from 30% to 60% and drumming is continued for a further hour, during

which time the removed hair is continuously screened out.

Residual hair removal

0.5% sodium sulphide (25% sulphide) and 1% lime are added to the existing float in order to remove residual hair from the hides.

The beamhouse utilizes four drums for unhairing (each has a capacity of ten tonnes rawhide). However, before the hair save process can be employed, these must be replaced by four purpose-built drums, each incorporating a special screening device needed to constantly filter out hair as it is removed from the hides. These sophisticated drums each cost US\$87 780 for the particular type chosen.

Four of the special screening drums are commissioned, and the new hair save process implemented. Analysis of the total mixed effluent resulting from this process shows the following effluent loadings:

- Solids42 692mg/l
- COD13 327mg/l
- BOD5 846mg/l

Materials audit



13 (i) What is the total volume of effluent produced during the 'hair save' unhairing and liming process?

(ii) What are the total mass of solids, COD and BOD discharged at this stage?

(iii) What is the relative difference to conventional unhairing and liming?

(iv) What quantities of sulphide and lime will be discharged from this process?

(v) How much have they been reduced compared to conventional unhairing/liming?

Answers to this question are on page IV:20

Financial audit

14 (i) What are the comparative daily chemical costs for the conventional and 'hair save' unhairing processes (based on 40 tonnes of rawhide per day)?

(ii) If the beamhouse operates for 220 days per year, what period of time would be required for the chemical cost savings to pay for the new screening drums?

(iii) Could this be considered an incentive to the adoption of hair save unhairing?

(iv) What other costs have to be taken into consideration?

Answers to this question are on page IV:21

General

15 What advantages and disadvantages can you identify for hair-save unhairing?

The answer to this question is on page IV:22

4.3.3 Splitting

The splitting procedure could have been carried out directly after green fleshing (before unhairing/liming), but the management decides to split in the limed state as it is more reliable.



16 In terms of process chemicals and pollution, what would have been the advantage of splitting immediately after green fleshing?

The answer to this question is on page IV:22

4.3.4 Deliming, bating and pickling

The use of ammonium sulphate or ammonium chloride as a weak acid in order to delime the hides has the advantage that the addition of excess to the float is unlikely to bring the pH much below 6.0; the strong buffering capability of the ammonium salt tends to maintain the pH at between 8.5 and 9.0, which is ideal for enzyme action during the subsequent bating process. However, we have seen that the use of ammonium salts results in ammoniacal nitrogen discharge in the effluent, together with ammonia gas discharge to the atmosphere (see question 9(i), page IV:8).

A cleaner production technique which avoids the use of ammonia is carbon dioxide deliming. Essentially, the gas is pumped into the drum headspace, allowing it to dissolve in the float. Carbonic acid is produced, and the float is buffered to pH = 7.

Although a different bating enzyme must be used (the pH is slightly lower), the float and subsequent process stages (washing and pickling) are unchanged.



17 (i) What is the environmental consequence of ammonium discharge in the effluent?

(ii) For a tannery operating conventional deliming, propose a method of preventing the discharge of ammonia gas to the workplace atmosphere:

(iii) Does your solution have any secondary environmental consequences?

The answers to this question are on page IV:22

Overall Pollution Audit Summary



- 18 Complete the overall pollution audit summary below for the cleaner production model assumed in the exercise. Assume that all reductions achieved by the cleaner production route have been indicated, with all other processes resulting in identical discharges.

Hint: It is easiest to work from the figures derived in question 11(ii) of this part, subtracting the savings obtained for cleaner processing to obtain the figures for the cleaner production column.

| Pollution from processing one tonne of rawhide | | | |
|--|-------------------------|--------------------|----------------------|
| Discharge/kg | Conventional production | Cleaner production | Percentage reduction |
| Effluent volume (m ³) | | | |
| Lime (total) | | | |
| Solids (inorganic) | | | |
| COD | | | |
| BOD | | | |
| Salt | | | |
| Sulphide | | | |
| Fleshings | | | |
| Trimnings | | | |
| Ammoniacal N in effluent | | | |
| Gaseous ammonia | | | |

The answer to this question is on page IV:23

4.3.5 Answers to the cleaner production work exercises

Raw material preservation

Question 12 page IV:14

- (i) The economic value of the salt saved per day is: $40 \times 415\text{kg} \dots\dots\dots 16.6 \text{ tonnes}$
 $16.6 \times \text{US\$}120 \dots\dots\dots \text{US\$ } 1\,992$
- (ii) The disadvantages of chilling are that it is a short term preservation method, and the hides must be processed immediately they are thawed. If no salt has been added, the 'green hides' are effectively 'live' – they have not been cured, and the cellular enzymes and bacteria remain highly active once thawing occurs. Another disadvantage is that a stock of raw hides can not be held at the tannery, which would cause problems over weekends or holiday periods. Refrigeration equipment can be purchased for use at the tannery to overcome this problem, but the capital cost is extremely high.
- (iii) $3 \times 80\text{m}^3$ soaks are used. By recycling the third, the total volume is effectively lowered from 240m^3 to 160m^3 (a reduction of 33%).
- (iv) The disadvantage associated with recycling the main soak liquor is that putrefaction has a higher chance of setting in; in recycling the water, we are also 'recycling' the bacteria that have not been destroyed by the biocide, enabling their concentration to build up.
- (v) To inhibit this effect, extra biocide must be added at each stage.

Unhairing and liming

Question 13 page IV:16

- (i) The total volume of effluent produced during the 'hair save' unhairing and liming process is:

| | | |
|--------------|----------------------|--------------------------|
| | $40\,000 \times 0.3$ | (impregnation) |
| + | $40\,000 \times 0.4$ | (wash) |
| + | $40\,000 \times 0.3$ | (hair protection) |
| + | $40\,000 \times 0.3$ | (unhairing) |
| Total | 52 000 litres | (52m³) |

- (ii) Effluent volume = 52 000 litres

Masses discharged are Solids..... 2 220kg
 COD 693kg
 BOD 304kg

- (iii) Comparing these figures with the appropriate masses obtained from the beamhouse audit in question 11(ii), we can see that the 'Sirolime' hair save process has resulted in the following reductions in discharge for the unhairing/liming stage:

| | | |
|---------------|--------------------------------------|----------------------|
| Solids | $1 - (2\,220 + 7\,400) \times 100\%$ | 70% reduction |
| COD | $1 - (693 + 3\,467) \times 100\%$ | 80% reduction |
| BOD | $1 - (304 + 1\,217) \times 100\%$ | 75% reduction |

Unhairing
and liming
continued

Question 13 continued

- (iv) (see Question 6.ii). The quantity of sulphide discharged from this process is:
- | | |
|---|--------------|
| 1% sodium hydrosulphide (impregnation stage) = $0.01 \times 40\,000\text{kg}$ | 400kg |
| 40% of this is sulphide | 160kg |
| 0.5% sodium sulphide (residual hair removal) = $0.005 \times 0.25 \times 40\,000$ | 50kg |
| Total sulphide | 210kg |
- The quantity of lime produced by this process is:
- | | |
|--------------------------------------|-------|
| $0.01 \times 40\,000\text{kg}$ | 400kg |
|--------------------------------------|-------|
- see question 4(ii)*
- (v) Sulphide reduction = $1 - (210 + 300) \times 100\%$ 30%
- Lime reduction = $1 - (400 + 800) \times 100\%$ 50%

Question 14 page IV:17

(i) Conventional costs

| | | |
|-----------------|----------------------------------|--------------|
| Sodium sulphide | $(40 + 100) \times 3$ | 1.2 tonne |
| | $1.2 \times \$545$ | \$654 |
| Lime | $(40 + 100) \times 2$ | 0.8 tonne |
| | $0.8 \times \$125$ | \$100 |
| | Total chemical cost | \$754 |

Hair save costs

| | | |
|----------------------|---|--------------|
| Sodium hydrosulphide | $40 + 100$ | 0.4 tonne |
| | $0.4 \times \$240$ | \$96 |
| Calcium hypochlorite | $40 + 100 \times 2.5$ | 1.0 tonne |
| | | \$50 |
| Lime | $40 + 100 = 0.4 \text{ tonne} \times 2$ | 0.8 tonne |
| | $0.8 \times \$125$ | \$100 |
| Sodium sulphide | $40 + 100 \times 0.5$ | 0.2 tonne |
| | $0.2 \times \$545$ | \$109 |
| | Total chemical cost | \$355 |

(ii) By changing to hair save unhairing, the chemical cost savings are:

$$\$754 - \$355 = \$399/\text{day}$$

$$\text{Yearly saving} = 220 \times \$399 = \$87\,780$$

This happens to be the cost of one screening drum, of which four were needed. The payback period is therefore **four years**.

(iii) Many companies require a payback of three years or less, and under these circumstances, the expenditure might be difficult to justify.

(iv) An additional consideration must be the reduction in effluent treatment charges resulting from the hair save process, compared to the added solid waste disposal costs for the recovered hair.

Unhairing
and liming
continued

Question 15 page IV:17

The *advantages* of 'hair save' unhairing are:

- 1 There is a large reduction in effluent COD and BOD loading.
- 2 There is a reduction in sulphide discharge.

The *disadvantages* are:

- 1 As the hair is no longer broken down, solid waste production increases. However, if a use could be found for the hair, e.g. as a slow release fertilizer, this would no longer represent a problem.
- 2 A far greater degree of process control is needed for a hair save system.

Splitting

Question 16 page IV:18

Following the splitting operation, only the 'grain split' (upper layer) is processed further. As the grain splits account for only 50% the original hide mass, all subsequent process stages would consume 50% less chemicals and result in 50% less pollution.

Deliming,
bating and
pickling

Question 17 page IV:18

(i) Ammoniacal nitrogen (ammonium) has a high oxygen demand and is toxic to aquatic life. It stimulates eutrophication, i.e. accelerated growth of plant life (algae and water weed), resulting in ecological imbalance. Heavy growths of these photosynthetic plants deoxygenates water further, and heavy growths of water weed can block the flow of rivers. Heavy growths of algae can be poisonous, block water purification systems, or accumulate on river banks, rot and become malodorous.

(ii) There are two possible solutions:

[a] Use of a weak acid instead of ammonium salts eliminates ammonia from the system.

[b] The second option is to use ammonium salts, and to remove the ammonia gas using gas scrubbing equipment containing recirculating acid.

(iii) [a] This is not associated with any secondary environmental consequences, but does need very strict process control in order to prevent the pH from dropping too low or too fast.

[b] The secondary environmental consequence is that liquid waste is produced.

Overall
pollution
audit
summary

Question 18 page IV:19

| Pollution from processing one tonne of rawhide | | | |
|--|-------------------------|--------------------|----------------------|
| Discharge/kg | Conventional production | Cleaner production | Percentage reduction |
| Effluent volume (m ³) | 15.5 | 7.8 | 50% |
| Lime (total) | 20 | 10 | 50% |
| Solids (inorganic) | 420.5 | 291 | 31% |
| COD | 133.3 | 63.9 | 52% |
| BOD | 43.5 | 20.7 | 52% |
| Salt | 415 | 165 | 60% |
| Sulphide | 7.5 | 5.25 | 30% |
| Fleshings * | 150 | 150 | 0 |
| Trimming * * | 120 | 120 | 0 |
| Ammoniacal N in effluent | 54 | 0 | 100% |
| Gaseous ammonia | 54 | 0 | 100% |

* Overall, the cleaner production process is associated with an *increase* in solid waste due to recovered hair (5-10% of rawhide weight).



Part 5

Tanning Process

| | | |
|------------|--|-------------|
| 5.1 | A tanning case study | v:3 |
| 5.2 | Answers to the work exercises | v:17 |

5 The Tanning Process

5.1 A tanning case study

This exercise examines a tannery which processes 40 tonnes of hides a day using a chrome-tan process. In order to meet new effluent regulations, the tannery has to upgrade several aspects of its operation.

The exercise will focus on the chrome effluent problem. The new regulations require an effluent standard of:

- *less than 5mg/l for discharge to sewer and*
- *less than 1mg/l for discharge to local streams.*

The upgrading also provides an opportunity to reduce operating costs at the tannery. By reducing the wastage of chrome in the effluent, the tannery hopes to reduce the \$2 000 a day it currently spends on chrome tanning agent. Chrome accounts for a large portion of the total chemicals costs in the beamhouse and tanyard.

This exercise will follow the waste audit procedure given in the UNEP/UNIDO *Audit and Reduction Manual for Industrial Emissions and*

Wastes. Technical information on Cleaner Production options for the tannery can be found in UNEP/UNIDO's Technical Report No. 4 *Tanneries and the Environment*.

The exercise follows the audit steps recommended in the Manual.

First, we examine the consumption of chrome tanning agent in the plant.

A number of alternatives – such as modified tanning agents, recycling, and chrome recovery – are then studied, and relative cost saving and effectiveness in meeting effluent standards are calculated.

These options are then compared to the cost of a treatment plant.

Please note that the figures used in this exercise do not represent an actual situation. They are ballpark figures drawn from various documents, and have been adjusted to make the calculations easier. Actual figures are, in any case, highly situation-specific.

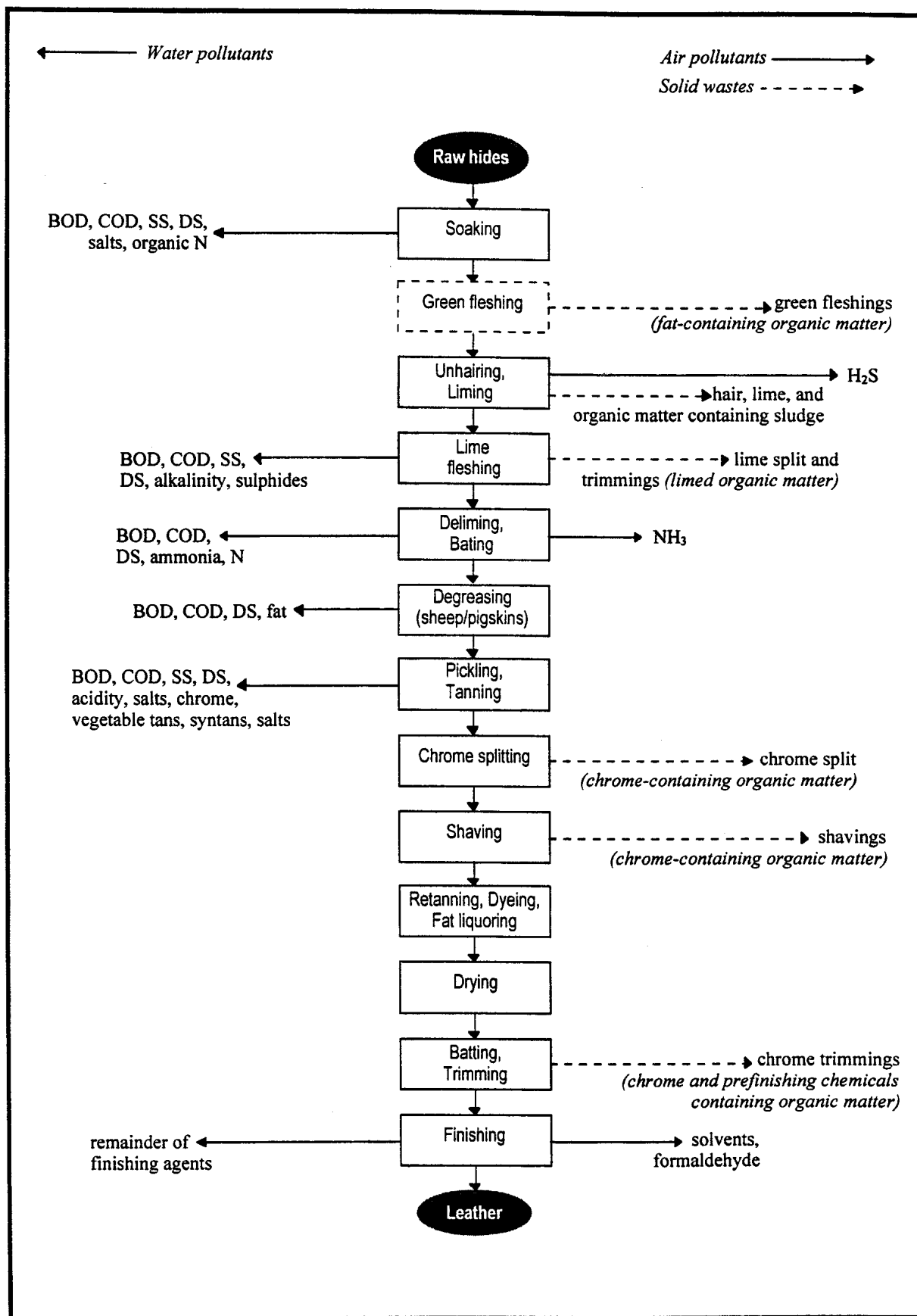
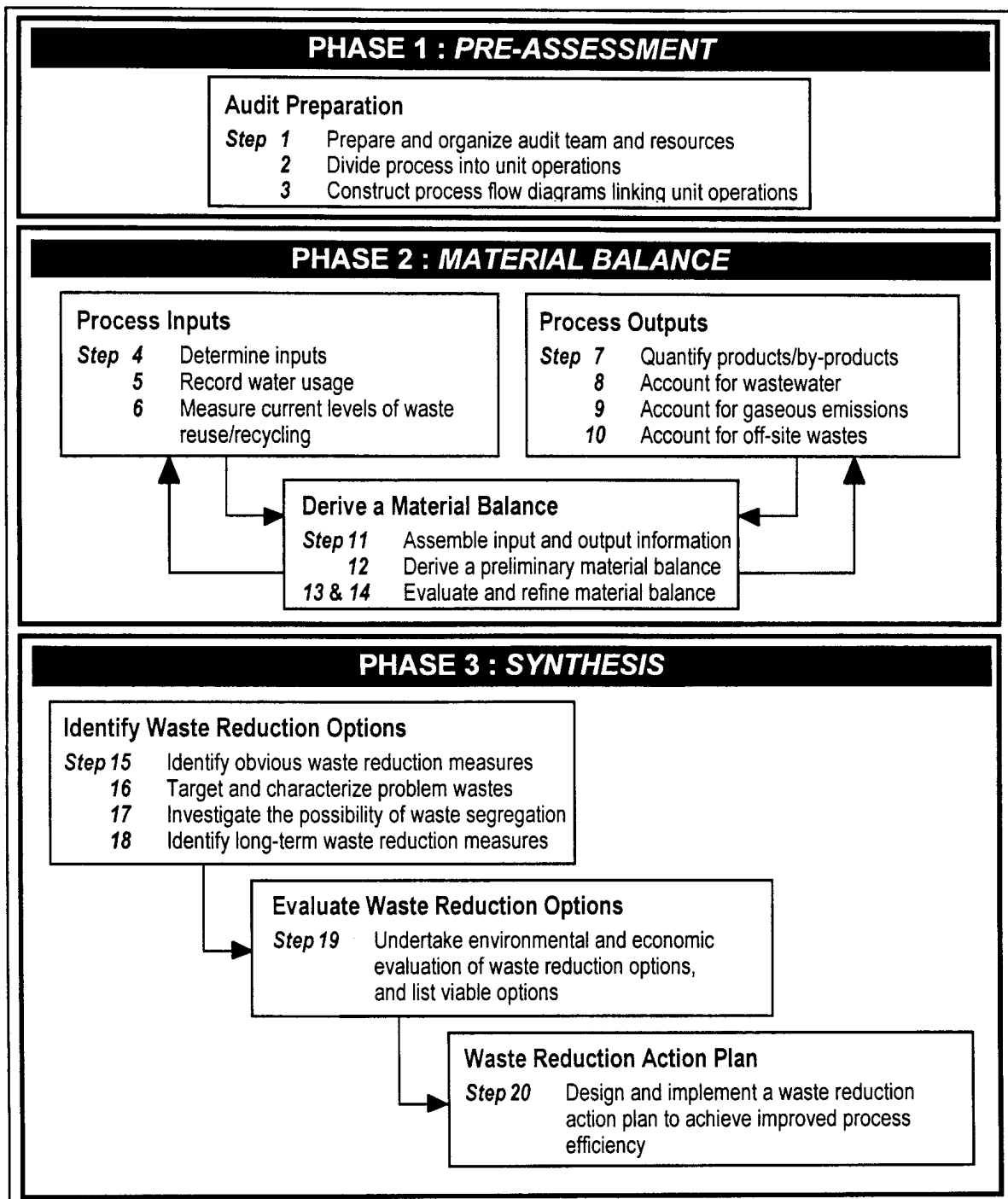

Figure 5.1 Schematic of the tanning process



5.1.1 Part I: Pre-assessment

- Refer to the diagram on page 123 of the Audit Manual.
- Refer to pages 69–74 of the Manual for plant specific details.
- Refer to Chapters 3 and 5.2 of the Tannery Guide.

Step 1: Audit team

Assume this has been done. You are it!

Steps 2 & 3: Unit Operations and Process Diagram

Refer to page 60 of the Manual. The diagram is reproduced here as *Figure 5.1 Schematic of the tanning process* on page v:5. Note where chrome chemicals enter the process, and where they leave.

5.1.2 Part II: Material balance

Steps 4, 5 & 6: Process Inputs (Cr)

Refer to pages 61, 62, 64 and 70 of the Audit Manual, and pages 21–27 of the Tannery Guide.

The key figures to note are:

| | |
|-------------------------|--|
| Hides processed | 40 tonnes/day fresh hides 35 tonnes/day fleshed hide |
| Process water (tannage) | 30m ³ /day |
| Rinse water (tannage) | 100m ³ /day |
| Total plant water | 1800m ³ /day |
| Tanolin (16% Cr) | 2076 kg/day (ca 322kg Cr/day) (ca 8kg Cr/tonne of fresh hides) |

There is no recycling of waters or solids.

Cost of materials:

| | |
|--------------------------------|----------------------------------|
| Water for tanning | (10c/m ³) \$17/day |
| Tanolin (\$1000/t) @ 16% Cr | \$2 000/day (ca \$7/kg of Cr) |

Expected absorption rate of Tanolin is 70% (i.e. 30% is wasted)

Steps 7, 8, 9 & 10: Process Outputs

Refer to pages 65, 66, 69 & 70 of Audit Manual, and pages 22–25 of Tannery Guide.

The key figures to note are:

| | |
|---|--|
| Chrome leather | 7 tonnes/day |
| Trimmings and shavings (after Cr tannage) | 7 tonnes/day <i>refer to p69 of Audit Manual and p25 of Tannery Guide</i> |
| Containing together Tanning liquors ¹ | 225kg/day of Cr 90kg/day of Cr (33m ³ /day @ 2 500mg/l) |
| Tanning rinsewaters | 7kg/day of Cr (2 000m ³ /day @ 1.5mg/l) |
| Total plant wastewater | 1 800m ³ /day |

¹ These waste streams account for the 30% of Tanolin that is not 'taken up' by the hide, and hence is releasor and washwater.



1 What is the concentration of chrome in:

(i) the spent tanning liquor?

(ii) the effluent from the tanning stage (*liquor and rinsewater*)?

(iii) the total combined plant wastewater discharge?

Answers on page v:17

2 Analysis shows that the concentration of chrome in the total combined plant wastewater is 70mg/l.

Give two reasons to explain the difference:

Answers on page v:17

Steps 11, 12, & 13: Materials Balance

Some simple flow charts for the process are shown below.

(i) Where the chrome goes

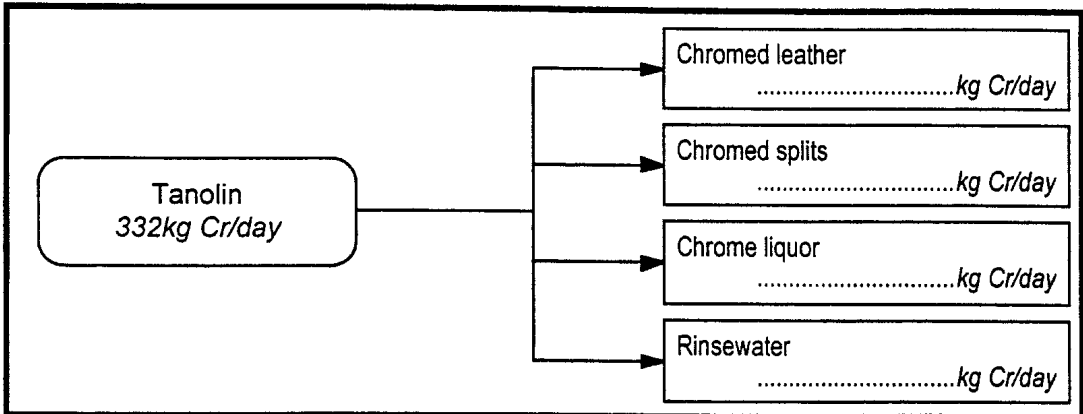

(ii) Where the water goes in the tanning stage

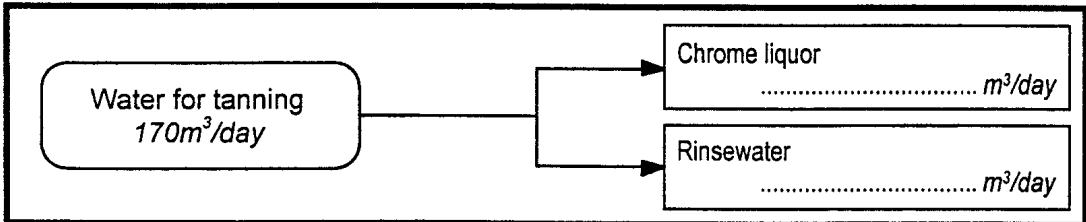

(iii) Where the hide goes

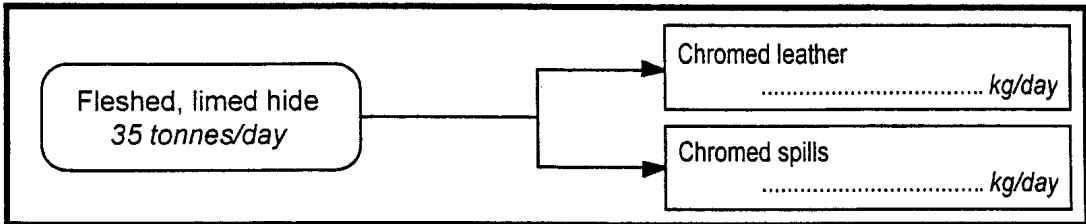

Check that the input/output balances correctly.

5.1.3 Part III: Synthesis

Step 15: Obvious Waste Reduction Measures

Refer to page 72 of the Audit Manual, and pages 36 and 37 of the Tannery Guide.

One of the simplest measures is **reduction in water use**. In many plants, a great deal of water is wasted with no process benefit. *More efficient rinsing* can also save a lot of water.



- 3 If a 50% reduction in rinsewater can be achieved with a batch rinsing system, how much water would be saved in the tanning process?

m^3/day

Answer on page V:17

- 4 How would this affect the concentration of chrome in:

(i) the rinsewater?

(ii) the plant's combined wastewater stream?

(iii) What is the direct cost saving achieved?

\$

Answers on page V:17

- 5 Another option to reduce the usage of water is through low float processing. What are the environmental benefits?

Answer on page V:18

Other obvious reduction measures include:

- reduced use of washwater in the factory and, importantly,
- action to reduce chemical spills

- ensuring containers are completely empty and
 - rinsing of containers to recover chemicals.
- However, we will not calculate these here.

5.1.4 Step 16: Identify problem wastes



6 From Steps 11–14, identify and give figures for –

(i) significant economic losses of chrome:

(ii) important sources of chromium wastewater that lead to difficulties with regulatory standards:

(iii) the most significant loss of water:

Answers on page V:18

5.1.5 Step 17: Waste segregation

At the moment all wastewaters enter the same drain for discharge.



7 (i) What is the chromium concentration in the combined effluent?

(ii) What are the possibilities for waste segregation?

(iii) What benefit would segregation have?

Answers on page V:18

5.1.6 Steps 18 & 19: Waste reduction measures

From Chapter 5.2, page 39–42, we learn that a number of options exist to reduce the chrome problem (apart from treatment, which is expensive).

Simply stated, these options are:

Option A

- Use high exhaustion chrome formulation instead of Tanolin.

This allows 90% chrome fixation in the leather, instead of the present 70%.



- 8 (i) What is the cost saving to the tannery? (Assume here the same price for this formulation*):

\$ /day

To what extent will this reduce the chrome in:

- (ii) the total effluent from the plant?

..... mg/l

- (iii) the effluent from the tanning stage?

..... mg/l

- (iv) the spent tanning liquor?

..... mg/l

- (v) What percentage of chrome fixation is required to ensure regulatory compliance?

**In fact, the high fixation formulation is about 30% more expensive.*

Answers on page v: 18

Note that high exhaustion tanning agents have the chrome in complexed form. Any remaining liquors are difficult to treat by normal

precipitation, and you should assume that unused complexed chrome is completely discharged to the drain.

Option B

- **Recover spent chrome** by collecting relevant effluents, and precipitating unused chrome for subsequent re-use (see page 40 of the Tannery Guide). Assume a 95% recovery rate. Assume the cost of this process is 30% of the cost of buying new Tanolin (on a chrome content basis). Ignore the capital cost of recovery plant for this exercise.



9 (i) What is the cost saving to the company?

\$..... /day

To what extent will this reduce the chrome in:

(ii) the effluent from the tanning stage?

..... mg/l

(iii) the total effluent from the plant?

..... mg/l

Answers on page v:19

Option C

- **Recycle the spent tanning liquor** to pickle or as make-up for subsequent tannage. Assume 67% of liquor can be recycled like this (see page 40 of the Tannery Guide). Assume capital costs for replumbing and pumps is negligible.



10 (i) What is the cost saving to the company?

\$..... /day

To what extent will this reduce the chrome in:

(ii) the remaining tanning liquors discharged?

.....

(iii) the entire effluent from the tanning stage?

..... mg/l

(iii) the total effluent from the plant?

..... mg/l

Answers on page v:19



11 (i) Compare options A, B, and C:

| Option | A | B | C |
|--|---|---|---|
| • Cost saving/day (\$) | | | |
| • Chrome in spent tanning liquor (mg/l) | | | |
| • Chrome in total tanning effluent (mg/l) | | | |
| • Chrome in final effluent from plant (mg/l) | | | |

(ii) Which option would you advise, and why?

Answers on page V:19

Option D

Here, we quickly look at *solid waste*.

A lot of chrome goes into trimmings and shavings when the tanned leather is cut to size. If the leather could be cut to size and shaved before tanning, then this chrome would be saved. However, untanned hide cannot be shaved.

A compromise is to give hide a *pre-tan* with, say, an aluminium tanning agent, to stabilize the hide. It is then trimmed and split.

The shaved hides (minus wastage) are then chrome tanned.

- Why not use aluminium tannage all the way through?

For the answer to this question, see page 44 of the Tannery Guide.

To investigate this option, recall that, in *Steps 7–10*, we found that:

- for 7 tonnes of leather/day, as much as 7 tonnes/day of trimmings and shavings are produced in this plant.

- The chrome content is the same at:

The answer is 7kg/t.

A further aspect is that chrome shavings cannot be re-used as fertilizer or animal feed ...

- Why not?

... and have to be dumped.

Now we will look at the effects of this option.



12 (i) What is the cost saving of this option, assuming process costs are the same?

\$ /day

(ii) What cost recovery is made if the non-chrome shavings are sold as animal feed for 10c/kg?

\$ /day

(iii) What is the effect of this option on the amount of chrome in the tannage wastewater?

(iv) What is the effect of this option on the level of chrome in the combined plant effluent?

Answers on page v:19

5.1.7 Step 20: Action Plan

Some of the above options could be *combined* to achieve even greater cost savings and reduced chrome levels in effluent.



13 (i) Propose the best combination of the above, assuming that no treatment of effluent occurs:

Option Calculate cost savings and final effluent level of chrome.

Cost savings: \$/day

Final effluent level: mg/l Cr

(ii) Assuming that some treatment will probably still be necessary, what combination would you propose?

(iii) Use of 2 000kg/day of Tanolin results in the release of 14 000kg of Na_2SO_4 . How does this influence your decision about the best option?

Answers on page V:20

Finally, we will quickly compare the reduction options with the conventional alternative of an effluent treatment plant.

Some notional figures for a chrome removal plant are:

- Capital cost..... \$20 000 with 100m³/d capacity (minimum \$50 000)
- Operating cost..... \$1 500/tonne of Cr removed (including transport and disposal costs of sludge).

A number of calculations are possible. Amortizing the capital cost requires a guess at interest rates, repayment periods and so on, which is too complicated here.

However, if you do want to include this calculation, assume that the loan is over 1 000 days, and interest doubles the capital cost.



14 (i) What is the cost of chrome removal from the tannery in its original condition (i.e. no reduction measures), assuming no flow segregation occurs?

| | |
|------------------------|---------------|
| <i>Capital cost:</i> | \$ |
| <i>Operating cost:</i> | \$ /day |

(ii) What is the cost of treating just the chrome liquor?

| | |
|------------------------|---------------|
| <i>Capital cost:</i> | \$ |
| <i>Operating cost:</i> | \$ /day |

(iii) What is the operating cost for treating the remaining high strength liquors from:

| | |
|------------------|---------------|
| <i>Option A?</i> | \$ /day |
| <i>Option B?</i> | \$ /day |
| <i>Option C?</i> | \$ /day |

The answers to these questions are on page v:21

5.2 Answers to the work exercises

5.2.1 Process Outputs

Question 1

page v:7

(i) The concentration of chrome in the spent tanning liquor is 3 000mg/l (90kg in 30m³).

(ii) The concentration in the effluent from the tanning stage is liquor plus tanning rinsewater. Process waste (tanning liquors) is 30m³/d. Effluent volume for tannage rinse is not measured, but can be calculated from water input for process minus strong liquors, i.e. 170 – 30 = 140m³.

Together, they contain a total of 97kg/day of chrome, as shown in the process outputs.

Chrome concentration is thus $97 \times 106 \text{ mg} / 170 \times 103 \text{ l} = 570 \text{ mg/l}$.

(iii) Chrome in total plant wastewater discharge is total chrome x total volume:

$$97 \times 106 / 1800 \times 103 = 54 \text{ mg/l}$$

Question 2

page v:7

Tannery effluent normally contains chrome-containing leather fibres, which will increase the total chrome concentrations in the final effluent. Another reason can be the uptake of chrome during tanning (assumed 70%). Uptake is strongly dependent on the type of tanning applied. A material balance should therefore be supported by sampling and analysis. Retaining is often done with chrome, which contributes to the chrome level in the final effluent.

5.2.2 Obvious Waste Reduction Measures

Question 3

page v:9

With a 50% reduction in rinsewater consumption, the saving in water is half the 140m³ used for tannage rinsing as shown in the process inputs, i.e. 70m³.

Question 4

page v:9

(i) The concentration of chrome in the rinsewater would be double the concentration produced traditionally: i.e. 100 mg/l.

(ii) The plant's overall water consumption would reduce by 70m³/d if only the tanning rinses were reduced.

Accordingly, there would only be a very slight reduction in total chrome concentration – but if *all* rinses in the factory were reduced by 50%, then the water savings would be much higher.

We can assume that most of the effluent volume is due to rinsing of various stages of processing, so a saving of up to, say, 800m³ could theoretically be achieved – although in practice, the volume would be less. As the amount of chrome used has not changed, the chrome concentration would then be around $97 \text{ kg} / 1000 \text{ m}^3 = 97 \text{ mg/l}$, higher than before.

(iii) Direct cost savings are due to reduced water use – i.e. 70m³ during tanning, or 800m³ overall, giving \$7 and \$80 savings respectively per day.

Other important cost savings can be expected from downscaling recycling systems and the effluent treatment plant. Some minor savings in reduced pumping costs, etc. would also occur.

Question 5
page V:9

Although low float processing in itself will hardly reduce the pollution load, it can improve the uptake of chemicals. A reduction of hot water consumption also entails reduced energy consumption.

5.2.3 Problem Wastes

Question 6
page V:10

(i) Significant economic losses of chrome occur in the discharge of tanning liquors ($97\text{kg/d} \times \$7/\text{kg} = \$679/\text{day}$ lost chemical), and especially the $(7000 \times 1.61\%) \times \$7/\text{kg}$ of chrome lost in trimmings and shavings per day. ($\$784/\text{day}$ equivalent).

Only a third of the chrome goes into useful leather.

(ii) Important chrome sources that lead to regulatory problems are:

[a] the discharge of spent process liquors which are very high in chrome ($3\,000\text{mg/l}$)

and

[b] chrome rinsewaters which are less concentrated but still a problem ($7\text{kg Cr}/1\,400\text{m}^3 = 50\text{mg/l}$).

(iii) The most significant loss of water occurs in rinsing, although this is inferred rather than stated for the entire factory. In the actual tanning process, the rinsewater discharge of 140m^3 is much higher than the process liquor at 30m^3 .

5.2.4 Waste Segregation

Question 7
page V:10

(i) Chromium content in combined effluent was earlier given as 54mg/l .

(ii) The possibilities of waste segregation should be good, given that the tanning stage is a discrete batch process, and the volumes are relatively low.

(iii) The benefit would be that only a relatively small volume – around $170\text{m}^3/\text{d}$ or less – would have to be treated for chrome removal, instead of the entire $1\,800\text{m}^3/\text{d}$ of total wastewater.

More significantly, the high strength process liquor ($30\text{m}^3/\text{d}$) could be economically recovered. Accordingly, the benefits include both *lower treatment costs* and some *cost recovery*.

5.2.5 Waste Reduction

Question 8
page V:11

Option A

(i) The cost savings depend a little on what is included. Certainly, reducing chrome loss from 30% to 10% will save 20% of $\$2\,000 = \$400/\text{day}$, if the cost of the formulation is the same. When the 30% higher cost of high exhaustion chrome is included, there will be no net cost saving if all unused chrome is discharged.

This shows why many tanners prefer to recycle high exhaustion chrome.

(ii) The chrome loss has been reduced to 10% of 322kg , i.e. $32 \times 1\,000/1\,800 = 18\text{mg/l}$, but still too high to be discharged without treatment.

(iii) In the tanning stage, the concentration will be reduced to $32 \times 1\,000/170 = 188\text{mg/l}$.

(iv) The spent tanning liquor will contain $1\,000\text{mg/l}$ chrome.

Question 8
continued

(v) All in all, just changing to high exhaustion chrome will reduce effluent concentrations, but not enough to ensure regulatory compliance.

Discharge to sewer requires a chrome level in the final effluent of $> 5\text{mg/l}$. With a total volume of $180\text{m}^3/\text{d}$. This means a discharge of g kg chrome which is equivalent with an uptake of $>97.2\%$.

Question 9
page V:12

Option B

(i) By recovering chrome from liquors and tanning rinses, 95% of the 97kg currently wasted can be recovered, i.e. 92kg. At 70% of new chrome cost, this represents a saving of \$450.

(ii) Chrome in tanning-stage effluent is reduced to zero, but some chrome is instead discharged from the recovery unit. Assuming about the same volume of liquid in this unit, we can simply assume 5% of the former value of 570mg/l; i.e. 28mg/l.

(iii) Chrome in total effluent from the plant is reduced to 2.7mg/l, acceptable for discharge to sewer (you will recall that this was 5mg/l), and nearly sufficient for discharge to surface water.

Question 10
page V:12

Option C

(i) If 67% of chrome float can be recycled to pickle, only 67% of the 90kg/d of liquor will be saved, i.e. $60\text{kg} \times \$7 = \420 .

(ii) The chrome level in the tanning liquors that are discharged will *remain the same*, because they cannot be recycled. Only the volume is reduced.

(iii) The chrome level in the effluent from the tanning stage will be reduced to $30 + 7\text{kg}/140 + 10\text{m}^3 =$ approximately 247mg/l.

(iv) The effluent from the plant will be reduced to $37\text{kg}/1800 = 21\text{mg/l}$.

This is still too strong to be discharged under the new regulations.

Question 11
page V:13

(i)

| Option | A | B | C |
|--|-------|-----|-------|
| • Cost saving/day (\$) | — | 450 | 420 |
| • Chrome in spent tanning liquor (mg/l) | 1 000 | 0 | 3 000 |
| • Chrome in total tanning effluent (mg/l) | 188 | 28 | 247 |
| • Chrome in final effluent from plant (mg/l) | 18 | 2.7 | 21 |

(ii) The most beneficial option for the tannery would be *Option B*. Chrome is significantly reduced in the effluent and the cost savings are the highest.

Question 12
page V:14

Option D

A total aluminium tannage gives a slightly different leather quality to chrome tanned leather. Using aluminium only for a pre-tan step avoids most of this problem. Also, aluminium tanned shavings are not toxic to animals, so they have some residual value as feed.

(i) By using an aluminium pre-tan step, the saving in chrome is $7\text{t} \times 16\text{kg/t} \times \$7 = \$784/\text{d}$. The cost of aluminium has still to be subtracted from this to calculate net savings.

Question 12
continued

(ii) The 7 tonnes of shavings can be sold for 10c/kg = \$700/d. This is perhaps somewhat utopian, but it does illustrate the possibilities.

(iii) The effect on chrome content in tannage wastewater depends partly on the reduction in the amount of chrome needed for final tannage. No data is given on this.

If we assume that the same amount is still required per m² of hide, then the chrome concentration is the same as that of the normal tannage effluent, i.e. the 570mg/l calculated earlier.

(iv) The total amount discharged by the tannery is, of course, reduced in proportion to the surface area (or mass) of hide that remains after trimming, i.e. 7/14 = 50% of the original.

Assuming that most of the plant effluent comes from beamhouse and pre-tan, then the change in total wastewater from the plant is not much changed (only 50% of 170m³ = 85m³ less, which is roughly 95%). The level of chrome in the final effluent is then reduced approximately by the amount avoided in use, i.e. 50% less, to around 27mg/l.

5.2.6 Action Plan

Question 13
page V:15

(i) Because the cost of high-exhaustion chrome is considerable, a simple useful option is to carry out aluminium pre-tan and trim before concluding with a normal chrome tan, plus recovering and recycling any remaining liquors for pickling.

This can reduce chrome consumption by ensuring none is wasted in splits, and that almost total re-use is made of strong effluents.

For the *first* batch, chrome consumption is reduced by 50% – i.e. to 161kg/d – thus saving \$1 000. Thirty percent of this remaining chrome is still left as waste liquor and rinsewater, which can be recycled to 95% level – a quantity of 46kg/d.

This recovered chrome can be used for the second batch at a cost of 30% of new chrome, i.e. around \$2/kg.

For the *second* batch, only 115kg of new chrome at \$7/kg is needed (\$805), plus 46kg of recycled chrome at \$2 = \$92. The total for the second and subsequent batches is thus \$897 instead of \$1 000.

So further savings are \$103/d, and the total savings are \$1 103/d. We ignore for simplicity the savings from any chrome recycled for pickling, regarding this more as effluent discharge avoidance.

If recovery can be carried out indefinitely (although it cannot, because other salts build up), the final level of chrome in effluent is determined by the remaining wastage of the 5% of float and rinsewater that cannot be recovered. This amounts to 5% of the reduced chrome needed for tannage, i.e. 5% of 48kg/d = 2.4kg/d. In the final total effluent, this will be 1.3mg/l.

(ii) If treatment is still necessary, then the use of high exhaustion chrome should be avoided. The same tanning combination as above would be appropriate.

(iii) If the discharge of large quantities of sulphate is a problem (e.g. to sewer systems), then the use of tanolin should be reduced as much as possible. The above combination of aluminium pre-tan and splitting before final tan, plus chrome recovery is very helpful in reducing tanolin consumption. Maximum use of spent float liquors for recycle to pickling could further avoid some sulphate releases.

5.2.7 Disposal options

Question 14

page v:16

(i) The original configuration of discharges was 97kg/d of chrome to effluent. The volume of wastewater is 1 800m³/d. To treat combined wastewaters requires a huge capital cost of \$360 000, and only \$145.5/d operating cost.

(ii) If only tannage liquor (or effluent) is treated, the capital cost reduces to the minimum of \$50 000, with the same operating cost.

(iii) The cost of treating *Option A* tannage effluent is $1/3 \times \$145.5 = \$7/d$.

For treating effluents from *Option B*, the cost is $0.05 \times \$14505 = \$48/d$.

For *Option C*, the cost is $0.33 \times \$145.5 = \$48/d$.

These cost reductions are not significant compared to capital costs for a treatment plant, nor to savings achieved by reducing chemical consumption.



Part 6

Leather Finishing

| | | |
|------------|---|--------------|
| 6.1 | Introduction to leather finishing | VI:3 |
| 6.2 | Leather finishing case study | VI:13 |
| 6.3 | Answers to the work exercises | VI:28 |
| 6.4 | Examples of chemicals used in leather finishing..... | VI:37 |

6 Leather Finishing

6.1 Introduction to leather finishing

Leather is seldom used without a surface coating and the finishing process refers to the application of the coating to the leather.

The nature and amount of finish applied to the leather depends on the leather itself and its intended market. High grade full grain leathers are lightly finished, sufficient to protect the surface without obscuring the grain. At the other end of the scale leather in which the grain has

been removed by buffing will be heavily finished with a pigmented base coat to give colour and a top coat on which a simulated grain pattern may be embossed by plating.

Since there is no detailed explanation of the leather finishing process in the technical guide *Tanneries and the Environment*, some additional technical background information is included in the first part of this section as a basis for the subsequent exercises.

In the following section, we will consider:

- Finishing materials
- Application methods
 - Effect of organic solvents on the environment
 - Environmental legislation on VOC emissions in the leather industry
 - Control of solvent emission to the atmosphere
 - Change of application methods
 - Water-based finishing systems
 - The importance of the base coat
 - Health and safety in the workplace
 - Summary

The second part of this section is a *Leather Finishing Case Study* in which you will be asked to use the information given in the first section to answer a number of questions dealing with a medium sized tannery producing 10 000m²

a week of corrected grain side leather (mainly yellow and red).

Annexes I and II contain, respectively, process guidance notes and health and safety data sheets.

6.1.1 Finishing materials

Finishing materials may be classified into two main groups:

- **binders:** such as waxes, proteins or synthetic polymers
- **additives:** such as pigments to give colour, or surface modifiers.

Binders

Waxes and coatings made from proteins such as casein and albumen are used mainly on vegetable tanned leathers. The material is applied to the surface and is then polished by glazing or burnishing.

Most leather is finished by the application of solutions or suspensions of synthetic polymers which may incorporate dyes or pigments or other additives.

A leather finish will usually consist of three layers:

- the **ground coat** to seal the leather surface or to promote adhesion of the subsequent coats, but not always necessary;
- the **base coat** which will carry the dyes or pigments to give the required colour;
- the **top coat** which will give the required surface texture and abrasion resistance.

In general, the first two coats will be water-based and contain acrylic or polyurethane polymers, or mixtures of both. The **top coat** could be polyurethane, nitrocellulose or cellulose acetobutyrate polymers in solution in an organic solvent or organic solvent/water mixtures.

Pigments

Organic and inorganic pigments are used to colour the finish. Chemical dyestuffs may also be used, but there is little difference between these and organic pigments as regards health and safety.

However, differences do exist between dyestuffs and organic pigments with respect to performance characteristics.

Inorganic types include iron oxides, lead chromates, chrome green, cadmium sulphide, ultramarine, titanium dioxide, carbon black and metallic pigments such as aluminium, bronze, copper, plus a subtype which is usually called an extender pigment.

Solvent-free top coats are now available; these are generally similar in polymer type to base coats, but may also involve the use of crosslinkers to improve the wet fastness properties. Crosslinkers are reactive chemicals that must be handled with care, and are hazardous with respect to health and safety.

Acrylic resins are the most commonly used resins in leather finishing.

Nitrocellulose and cellulose aceto-butyrate polymers are the most widely used solution polymers; they provide extremely flexible films and give high performance top coats with excellent aesthetic characteristics.

However, the solvents used are very volatile and present a health and safety risk, as well as being detrimental to the environment.

To counter this, emulsions of these resins have been produced where the resin is dissolved in a high-flash point solvent and the solution dispersed in water to give a so-called lacquer emulsion but the amount of solvent used can give emissions higher than permitted levels.

Organic types include mono azo, diazo, toners, lakes, phthalocynaine, metal complex and vat pigments.

The characteristic properties of a pigment depend on the type. Inorganic pigments are usually dull in colour, have excellent light fastness, thermal stability, high opacity, resistance to bleeding, resistance to chemicals and are easier to disperse. Organic pigments are brightly coloured, variable in light fastness and heat stability. They have poor opacity, variable resistance to bleeding and chemicals and are more difficult to disperse. Examples of chemicals used in leather finishing are shown in Section 6.4. Some Materials Safety Data Sheets are shown in Annex II.

Fastness properties are often reflected in price: cheaper organic pigments exhibit poor properties and very expensive ones can satisfy the highest demands made of them.

Inorganic pigments containing lead chromate and cadmium sulphide were the biggest cause of

concern with respect to health and safety, both of these metals being considered toxic. These pigments cover a range of colours from yellow to red and their use is now highly restricted in Europe. The replacement organic pigments do not yet have equivalent performance.

6.1.2 Application methods

There are four methods used in the leather industry to apply finishes:

- *Pad coating*
- *Curtain coating*
- *Spraying*
- *Roller coating*

Pad coating

Pad coats are usually applied by means of a plush pad – a wooden board covered with a soft velvet-like cloth. It is done by hand and is,

therefore, labour intensive but it does ensure that the finish is worked well into the leather and evenly applied across the hide.

Spray application

The most common method of applying the finish is by the use of a fine jet in the atomising part of a spray gun. This applies the finish to the leather in finely dispersed form. Compressed air is normally used to produce the necessary pressure. Spray application is usually

carried out by multigun machines, although some small scale work may be applied by a hand-held gun. Spraying can be wasteful in several ways:

- by overspray at the edges
- by overspray between the pieces
- the spray bouncing back.

Curtain coating

Curtain coating involves applying the finish to leather in the form of a liquid curtain.

Gap machines are particularly useful for applying heavy coats of finish, but their use in the industry is limited.

Roller coating

With this application technique, the finish is applied by passing the leather between two cylinders, one of which is coated with the finish which is transferred to the leather.

There are two types of roller coating:

- **forward**
- and
- **reverse.**

In *reverse coating*, the application roller revolves in the opposite direction to the feed roller. This can give higher levels of finish

application and better adhesion, but can also cause feed problems with softer leathers.

This application technique is becoming more widely used, and the type of machine used depends on the application.

Base coats, impregnations, solvent and water-based top coats can be applied by roller coating. Because higher concentrations of resins can be used than with spraying, a 60-70% lower proportion of diluents is achieved.

6.1.3 Effect of organic solvents on the environment

The best top coats are those in which organic solvents are used. They give stronger, more flexible, more water resistant coatings, but incur an environmental risk.

Many organic solvents, particularly those with boiling points less than 125°C, are classified as *Volatile Organic Compounds (VOCs)*.

VOCs are a large family of carbon-containing compounds. When they are emitted or evaporate into the atmosphere, they can take part in photochemical reactions in the air to produce smog.

Concern about VOCs

There is national and international concern about VOCs for four main reasons:

- 1) some of them contribute to stratospheric ozone depletion;
- 2) some of them are toxic or carcinogenic;
- 3) most of them make an indirect contribution to global warming; and
- 4) most of them contribute, in varying degrees, to the formation of ground level ozone.

This last factor is the main reason for concern with VOCs. Ground level ozone adversely affects human and animal health, and can damage vegetation and materials.

Measures to reduce these emissions are already in hand.

The major sources of VOCs are:

- road transport
- industry
- the use of solvents.

Catalysts on cars will reduce their VOC emissions leaving industrial VOC emissions as the next significant source to target for reductions.

Many countries, including the European Union Countries, have laws restricting the use of organic solvents, and imposing strict limits on the amount and concentrations of VOCs that can be discharged from a factory. This trend is expected to continue.

Environmental legislation on VOC emissions in the leather industry

The mass emission figure for volatile organic compounds should be calculated using the following information:

- (a) total quantity of leather coated (m^2),
- (b) coating material usage,
- (c) organic solvent content of coatings,
- (d) diluent organic solvent usage,
- (e) total cleaning solvent usage.

The mass emission of volatile organic compounds per m^2 of leather coated, calculated in accordance with the above, should not exceed:

- (a) $185g/m^2$ for new processes,
- (b) $185g/m^2$ for existing processes from 1 April 1995
and
- (c) $75g/m^2$ for all processes from 1 April 1999.

Where it is necessary to install equipment to meet these limits, emissions limits are as follows:

| | * Maximum concentration mg/m^3 | Maximum volume | Minimum usage at which limits apply |
|---------|----------------------------------|--------------------------------------|-------------------------------------|
| Germany | 150 | 3 g/h | 50 kg/h |
| UK | Solvent | 75 g/m ² | 5 t/yr |
| | Particulate | 50 | — |
| USA | | 0.725 kg solvent per litre of finish | various |

* Expressed as total carbon excluding particulate matter.

Legislation on the use of organic solvents is complex with a variety of methods of imposing limits, some based on usage alone, some on emission concentration limits, and others based on a combination of both.

The most clearly stated, and enforced, are those in Germany and the UK, and the most useful reference document for the control of organic solvents in the leather industry is the *A Guidance Note PG6/22(92)* issued by the Department of the Environment.

6.1.4 Control of solvent emission to the atmosphere

There are three ways of reducing the amount of organic solvent emitted to the atmosphere:

- **Arrestment** (installing plant to remove the solvent from the air flow)
- **Change of application** method (roller coating uses less solvent than spray coating)
- **Water-based finishing systems**

Arrestment is expensive, requiring large capital investment. Moreover, changing the application method to get more efficient use of the finish still leaves the problem of solvent emission from the drier.

The most effective method is the substitution of organic solvents by water, either partially or completely, though partial substitution may not be sufficient to meet the legislative limits.

Arrestment methods

Various methods are available to reduce the emission of solvent vapours. The choice of technique will depend on a number of parameters relating to the nature and scale of the process.

Arrestment methods can be divided into two groups:

- *Arrestment with solvent recovery*
- *Arrestment without solvent recovery.*

Arrestment with solvent recovery

Absorption (scrubbers)

The exhaust gases are passed through a water curtain. Operating costs can be low, whilst recovery yields are high, provided air temperatures are near ambient and solvent vapour concentrations are high (50g/m^3). Mixtures of solvents can give problems.

Adsorption

The solvent is adsorbed onto an activated solid, usually carbon, then desorbed for recovery. This method can provide high yields for vapour concentrations ranging from 1g/m^3 to 50g/m^3 and is applicable for a large range of flow rates.

Condensation

Solvents are condensed out of the air stream by cooling to low temperatures.

This technique is only suitable for high vapour concentrations and low flow rates of less than $3000\text{m}^3/\text{h}$.

Arrestment without solvent recovery

Biotreatment

Exhaust gases can be fed into a bed in which micro-organisms destroy the solvent. This technique requires large areas and is suitable mainly for low concentrations of solvent components.

Incineration

Exhaust gases are fed into combustion chambers at temperatures of $750\text{-}1200^\circ\text{C}$ where they are converted into CO_2 and H_2O . This method can be expensive in fuel usage.

Catalytic incineration reduces the temperature required to about $200\text{-}500^\circ\text{C}$ and reduces the fuel requirements significantly.

However, higher capital cost are incurred than conventional thermal incineration, and it is generally unsuitable for leather finishing systems because the resin particles in the stream poison the catalyst.

Change of application methods

The most obvious way of reducing solvent usage is to use roller coating application rather than spraying. The finishing system has a much higher solids content and therefore less solvent usage per unit area of leather.

Roller coating also uses the finishing materials more efficiently as there is no bounce back or overspray wastage.

However, although roller coating reduces emissions of VOCs at the application stage, the

problem is merely transferred to the drying stage (if solvents are used). Roller coating is also not suitable for certain leathers (very thin leathers, for example), and is not believed to give a quality of finish comparable to that achieved with spraying.

As a compromise, new spraying methods have been developed to meet the need for more efficient use of finishing materials. The term '*transfer efficiency*' is used as a measurement of the efficiency of the application system.

6.1.5 Transfer efficiency

Transfer efficiency is the percentage of applied finish which is deposited on the leather. The formula is:

$$\text{Transfer efficiency} = \frac{\text{weight of finish deposited}}{\text{weight of finish sprayed}} \times 100$$

Conventional high pressure guns have a transfer efficiency of 35-45%.

Techniques developed to improve the transfer efficiency include:

- *Air assisted airless guns* (with transfer efficiency of 40-70%)

- *High volume low pressure (HVLP) guns* (transfer efficiency 50-75%)

It should be noted that improving the efficiency not only reduces the impact on the environment, but also reduces finishing costs.

6.1.6 Water-based finishing systems

It is important to note that the need to replace organic solvents refers mainly to top coats. It is unusual to use organic solvents for base coats. The best solution to the problem of organic solvents is to use aqueous systems.

Aqueous systems for top coats can be divided into two groups:

- *Low solvent systems*
- *Solvent free systems*

Low solvent systems

Low solvent systems are generally emulsion lacquers containing between 10% and 30% organic solvent.

The emulsifiers used, however, remain in the top coat film after drying and can reduce the wet

fastness compared to solvent systems. The solvent content can still be high enough to present problems with VOC emissions, and they do not always meet the concentration limits.

Solvent free systems

Solvent free top coat resins present the most effective method of reducing emissions of VOCs to the atmosphere.

Acrylates and polyurethanes are prepared as solvent free aqueous emulsions, and these resins

are lightfast, resistant to ageing, have excellent rubfastness and waterproof properties.

By choosing the appropriate resins and additives, finishing systems can meet the requirements of all types of leather: clothing, shoe upper, upholstery and automotive.

The main problem in water-based top coats is the water itself, rather than the properties of the resins which can be used.

Water has poor flow properties, particularly when applied to a non-absorbent base coat, forming droplets on the surface, rather than a coherent film.

Therefore, much heavier deposits are required to achieve a continuous film and to produce

equivalent performance to a solvent based top coat. The heavier deposits detract from the feel and appearance of the leather.

Higher molecular weight polymers tend to give better fastness properties. Performance is also increased by the addition of crosslinkers which improve the resistance to water by reacting with the hydrophilic groups in the polymer which aid water penetration. Crosslinkers may also bond the base and top coats, improving inter-coat adhesion.

It is also important that all the finish is completely dried since water left in the finish film acts as a plasticiser, and interferes with the formation of the final film.

6.1.7 The importance of the base coat

Because good wet-rub fastness can be achieved with organic solvents, this quality was never considered to be important in base coats.

However, the wet-rub fastness of water-based top coats is generally inferior to that of solvent-based top coats.

In this case, then, the wet-rub fastness of the base coat is important and needs to be as high as possible to compensate for the loss of performance of the top coat.

When switching to aqueous top coats, the base coat must be regarded as an integral part of the formulation.

6.1.8 Health and safety in the workplace

Hazards in the workplace

These may be classified as:

| | | |
|------------------|---------------------|---|
| Common hazards | <i>general</i> | – cuts, burns, falls, back injuries. |
| | <i>carelessness</i> | – horseplay, ignoring warning signs, leaving equipment on, untidiness, lack of maintenance. |
| Specific hazards | <i>machinery</i> | – noise, moving parts. |
| | <i>substances</i> | – toxicity, fire. |

Removal and reduction of hazards

To assess a hazard it must first be recognised.

The recognition of a hazard is a first and major step towards preventing an accident.

Common hazards

The risk from common hazards is mainly dependent upon human behaviour, and the workplace is only as safe as the most dangerous person working in it. This is largely an issue for training and maintenance.

Specific hazards

Machinery moving parts

Training in the correct use of modern machinery should remove hazards from moving parts. Older machinery should be assessed to see if extra guarding is required.

Machinery noise

Noise levels should be monitored to see if they are increasing or if ear protection is required. High noise levels may be an indication of loose

parts or wear on machinery. Regular checking and maintenance of machinery is required to reduce risk.

Substances

Substances such as finishing materials will not all produce the same hazards. The health and safety data sheets should be consulted and the appropriate action taken as regards handling, mixing, storage and use. (Some examples of HSDSs are in *Annex II*).

Certain potentially harmful substances have occupational exposure limits which are, in the UK, published on an annual basis by the Health and Safety Executive (Guidance Note EH 40). The tables are in three sections:

a Maximum Exposure Limits (MEL). These are limits set out in the COSHH Regulations and must not be exceeded.

b Occupational Exposure Standards (OES). This section covers the majority of substances and gives recommended limits.

c Changes to Recommended Limits. This is a form of advance notice relating to changed or additional recommended limits.

The *Occupational Exposure Limits* are updated annually and the latest edition should be consulted for the actual levels.

Many countries have similar regulations covering safety in the workplace.

Waste disposal

The treatment and disposal of wastes is dependent upon the toxicity of the substances concerned. The EEC law dealing with this is called the *Directive on Pollution Caused by Certain Dangerous Substances, Discharged into the Aquatic Environment of the Community (76/464/EEC)*.

Water quality is protected by eliminating pollution from substances on a black list, and reducing pollution from substances on a grey list. Substances on the black list are selected for high toxicity, persistence in the environment and bio-accumulation, e.g., cadmium. Substances on the grey list are considered less toxic, but some may soon be transferred to the black list, e.g., lead and chromium.

The production of waste should be kept to a minimum, but some waste will always be left over from finishing or cleaning. Aqueous and solvent wastes must be kept separate. However, the solvent used in finishing is not chlorinated. If it was, it would also need to be kept separate from non-chlorinated waste solvents.

All waste is best removed by a competent licensed waste disposal contractor. Solvent waste may be recovered or incinerated, whilst aqueous waste needs treatment by flocculation and sedimentation, followed by filtration and incineration or landfill. Any waste containing black or grey list materials is subject to special disposal regulations.

Protective equipment

Clothing

Most general types of clothing are acceptable. However, a fully enclosed type of shoe should be worn in preference to sandals, and care should be taken with ties and jewellery when operating machinery.

If overalls or other types of protective clothing are worn it is important that it is kept in good repair, as torn or ragged overalls can present a danger.

Boots with safety toecaps should be worn in situations where heavy objects represent a hazard.

Eye protection

The three types of eye protectors are:

- 1 Plastic rimmed safety spectacles with side shields.
- 2 Plastic safety goggles. These offer better protection against splashes from the side.
- 3 Full face shields which protect the face as well as the eyes.

Hand protection

Certain solvents and other materials encourage the development of dermatitis. Barrier creams provide protection against oils and general chemicals, etc. Disposable gloves allow the wearer to retain good dexterity but have relatively poor solvent resistance. Household gloves may also disintegrate or be permeable to certain solvents. Several types of solvent-resistant gloves exist, e.g., Neoprene, polyvinyl alcohol and nitrile. Selection is dependent upon the type of solvents being handled.

Hearing protection

Disposable earplugs are made from glass down, plastic coated glass down and polyurethane foam, while reusable earplugs are made from semi rigid plastic or rubber. Reusable earplugs need to be washed frequently.

Ear muffs consist of rigid cups to cover the ears, held in position by a sprung head band. The cups have acoustic seals of polyurethane foam or a liquid filled annular sac.

Respiratory protective equipment

Respirators purify the air by drawing it through a filter which removes most of the contamination, whereas breathing apparatus supplies clean air from an uncontaminated source.

There are five basic types of respirator:

1 Filtering face respirator

The face piece covers the whole of the nose and mouth and is made of filtering material which removes respirable size particles. (These should not be confused with nuisance dust masks which simply remove larger particles).

2 Half mask respirator

A rubber or plastic face piece covers the nose and mouth and has replaceable filter cartridges.

3 Full face respirator

A rubber or plastic face piece covers the eyes, nose and mouth and has replaceable filter canisters.

4 Powdered air purifying respirator

Air is drawn through a filter and then blown into a half mask or full face piece at a slight positive pressure to prevent inward leakage of contaminated air.

5 Powdered visor respirator

The fan and filters are mounted in a helmet and the purified air is blown down behind a protective visor past the wearer's face.

Filters are available for protection against harmful dusts and fibres and also for removing gases and vapours. It is important that respirators are never used in oxygen-deficient atmospheres.

The British Standard *BS 4275* gives guidance on the selection, use and maintenance of respiratory protective equipment.

Emergency training

In the case of chemical accidents the ideal first aid treatments for individual materials are given on the material safety data sheets and should be consulted prior to using the materials.

The information below is a general guide to treatments.

Any person treating a chemical casualty should always bear in mind his or her own safety. There may, for example, be toxic fumes remaining in the area or the casualty may be so contaminated as to constitute a hazard to a first aider. In such cases, gloves may have to be worn.

Medical attention should always be obtained in the following cases:

1. All accidents involving the eyes
2. All cases involving ingestion of toxic chemicals
3. All cases when doubt exists.

Full information regarding the accident and the chemicals involved should always be given to the hospital or doctor concerned.

General treatments

Splashes on the skin

Flood the affected area with large quantities of running water. Removal of insoluble agents will be facilitated by cleaning the contaminated area with soap. Remove all contaminated clothing, taking care not to contaminate yourself in the process.

Splashes in the eyes

Flood the eye thoroughly with large quantities of gently running water from a tap or an eyewash bottle. Continue for at least ten minutes. Ensure the water bathes the eyeball by gently prising

open the eyelids and keeping them apart until the treatment is completed.

Inhalation accidents

Remove the casualty from the danger area and loosen clothing. If the casualty is unconscious, place in the recovery position (i.e., lying on the front with the head to one side and tilted backwards) and monitor breathing. If breathing

has stopped, apply artificial respiration by the mouth to mouth method.

Ingestion of toxic chemicals

If the chemical has been confined to the mouth, give large quantities of water as a mouth wash but ensure the mouth wash is not swallowed. Do not induce vomiting as this may worsen the situation, particularly when corrosives or solvents are involved.

Fire prevention

Flammable vapours

These must be kept to a minimum by only using solvents under conditions where the fumes are efficiently extracted.

Flammable liquids

These must be stored in an appropriate place as given on the data sheets. Waste must be correctly disposed of, never poured down the sink.

Fire exits and alarms

All staff should ensure that they know the locations of the fire alarms and exits, which should never be blocked or obstructed.

Fire drill

Any person discovering a fire should sound the alarm by breaking the glass on the nearest alarm point. This must be done before any attempt is made to extinguish the fire.

If it is safe to do so, make an attempt to extinguish the fire using an appropriate extinguisher.

If this is not immediately successful then the fire should be left, but doors should be closed in an attempt to restrict its spread.

6.1.9 Summary

- Arrestment methods for removing VOCs from exhaust gases are expensive to install and run.
- New spray gun technology and roller coating reduce organic solvent wastage and emissions to atmosphere.
- Water-based top coats offer the most effective means of reducing solvent emission.
- Water-based top coats can meet many of the performance standards of solvent top coats, but require different formulation and application procedures.
- Safety in the workplace requires attention to many factors of plant operation and personal protection.

6.2 Leather finishing case study

We will now consider a medium-size tannery producing 10 000m² a week of corrected grain side leather mainly in yellow and red colours.

The main methods of application currently used are curtain coating for the impregnation layer, padding for the first base coat layer, and spraying for the subsequent base coat layers and the top coat.

The formulations used for each coat are:

| | Parts | Cost by weight (US \$/kg) |
|--|-------|------------------------------|
| Impregnation system (curtain coat x 1) | | |
| Acrylic resin emulsion 1 (40% solids) | 200 | 2 |
| Methoxy propanol (100% solvent) | 100 | 1 |
| Water | 700 | — |
| Base coat (pad x 1, spray x 2) | | |
| Acrylic resin emulsion 2 (40% solids) | 250 | 2 |
| Lead chromate pigment suspension (30% solids) | 150 | 2 |
| Wax modifier | 50 | 2.5 |
| Water | 550 | — |
| Top coat (spray x 2) | | |
| 40% Nitrocellulose solution (40% solids, 60% solvent) | 300 | 3 |
| Methoxy propanol (100% solvent) | 695 | 1 |
| Silicone oil | 5 | 5 |

6.2.1 Process details

Curtain coating

Weir-type machine applying 215g/m² wet weight of impregnant to the leather.

Wastage approximately 3% including material lost during cleaning.

Padding

Applied by hand: giving 95g/m² wet weight of finish to the leather (subsequent pad coats, if applied, would give approximately 60g/m², since the coated leather is less absorbent).

Wastage approximately 6% including cleaning.

Spraying

Four head conventional reciprocating spraying machines set at optimum to deliver 363g/min per

gun to give a coating of 33g/m² wet weight on leather.

Transfer efficiency = 35%

$$= \frac{\text{weight of finish deposited}}{\text{weight of finish sprayed}} \times 100$$

Throughput of leather 750m²/h.

Exhaust gases discharged through a water curtain to atmosphere at an air flow of 15 000m³/h. Efficiency of particulate capture 95%, of solvent capture of 20%.

Assume equal delivery for base and top spray coats.

6.2.2 Questions



1 Calculate the amount of solvent used per square metre of leather during:

(i) impregnation

(ii) top coat application

The answers to this question are on page VI:28

2 (i) What is the total solvent usage per week during application?

(ii) Are there any other sources of solvent emission?

Two coats of base coat are applied by spraying.

(iii) What are the cost and environmental implications?

(iv) What changes would you suggest?

The answers to this question are on page VI:28



3 (i) Which component of the base coat presents a risk to health?

(ii) What might this be replaced by?

(iii) In what way will this replacement affect performance, and how may this be overcome? (assume equal cost for replacement materials)

The answers to this question are on page VI:29

4 (i) • Calculate the total weight of resins, pigment and solvents used in a week's production based on estimates given.

• Identify the amounts of resin, pigment and solvent wasted in a week.

Use the table on the following page to record your results.

(ii) Can you suggest a simple record-keeping procedure to monitor usage?

The answers to this question are on page VI:29

Question IV:4 (i) Material Usage 1

| | RESIN | | | SOLVENT | | | PIGMENT | | |
|------------------------------|----------------|---------------|--------------|----------------|---------------|--------------|----------------|---------------|--------------|
| | <i>applied</i> | <i>wasted</i> | <i>total</i> | <i>applied</i> | <i>wasted</i> | <i>total</i> | <i>applied</i> | <i>wasted</i> | <i>total</i> |
| Impregnation | | | | | | | | | |
| Base coat | | | | | | | | | |
| Padding | | | | | | | | | |
| Spray 1 | | | | | | | | | |
| Spray 2 | | | | | | | | | |
| Top coat | | | | | | | | | |
| Spray 1 | | | | | | | | | |
| Spray 2 | | | | | | | | | |
| Total g/m² | | | | | | | | | |
| Total/Week kg | | | | | | | | | |



- 5 (i) Assuming that 80% of the solvent used in the top coat application is exhausted through the vent of the spray cabinet, what is the estimated concentration of organic solvent in the exhaust gases during top coat application?

Organic solvents in emissions are measured as total carbon and, in general, this figure is about 60% of the organic solvent concentration.

- (ii) Is this concentration likely to comply with legislation in Germany or the UK?

- (iii) Comment on the water curtain as a method of reducing solvent discharge into the atmosphere.

The answers to this question are on page VI:31

The answers to the questions in the previous section should have shown that the finishing department in this tannery has excessive emissions of solvent. The main concern over organic solvents in the atmosphere is that they react with nitrogen oxides in the air and interfere with the destruction of ozone in the lower atmosphere. They also form dangerous compounds through free radical oxidation reactions.



6 *optional*

- (i) Can you suggest mechanisms by which these chemical effects occur?

- (ii) What is the effect on the lower atmosphere?

The answers to this question are on page VI:31

The tannery in this example will have to take measures to reduce its solvent emissions significantly. There are three possible courses of action:

- *Arrestment*
- *More efficient application methods*
- *Elimination of the use of solvents*



7 On the basis of the figures given, the best cost option would be the adsorption plant. Considering the adsorption plant and using the information given below, would it be more economical to dispose of or regenerate the waste solvent:

(i) assuming 100% efficiency?

(ii) assuming 50% efficiency?

The answers to this question are on page VI:31

Arrestment

There are several methods of arrestment, and the choice of method depends on a number of factors. A full analysis is beyond the scope of this exercise, but for a typical tannery, only two need be considered:

• *Adsorption*

These methods have been shown to be effective at the exhaust air flow rates (10000-20000m³/hr) and VOC concentrations (500-5000mg/m³) encountered in tanneries.

Adsorption

Uses active carbon, generally, to remove the solvent from the air stream. Over a period of time, the carbon becomes saturated and needs to be regenerated. This is done by raising the temperature of the carbon filter bed releasing the solvent, which is then removed by the carrier gas, usually steam.

The main concern about organic solvents in the workplace is the toxicity/carcinogenicity of many

• *Incineration*

of these products with respect to the health and safety of the personnel.

Incineration

The polluted air is passed into a furnace large enough and at a high enough temperature to ensure the complete oxidative breakdown of the organic solvents.

Large amounts of fuel are required to keep the temperature high enough.

Catalyzed incineration, in which a lower temperature may be used, is unsuitable for finishing shops because any resin or pigment particles would destroy the activity of the catalyst.

The capital and running costs for an adsorption plant, and two incinerators, one with a heat exchanger are given below.

**Arrestment
plant costs**

| | |
|---|-------------------------|
| Air flow | 15 000m ³ /h |
| VOC concentration | 3 000mg/m ³ |
| <i>Plant in operation for 2 000 h/year. Depreciation over 10 years straight line.</i> | |
| Cost of capital | 15% p.a. |
| Cost of disposal of recovered solvent | \$105/t |
| Cost of regeneration of recovered solvent | \$250/t |

| | Adsorption US \$ | Incinerator US \$ | Incinerator with heat exchange US \$ |
|-----------------------------|---------------------|----------------------|---|
| <i>Installed cost</i> | 180 000 | 93 000 | 250 000 |
| <i>Annual costs</i> | | | |
| <i>Carbon replacement</i> | 1 040 | — | — |
| <i>Steam</i> | 5 600 | — | — |
| <i>Electricity</i> | 4 800 | — | — |
| <i>Fuel costs</i> | —95 000 | 29 000 | |
| <i>Labour/maintenance</i> | 6 000 | 8 000 | 8 000 |
| <i>Depreciation</i> | 18 000 | 9 300 | 25 000 |
| <i>Cost of capital</i> | 27 000 | 13 950 | 37 500 |
| Total (annual costs) | 62 440 | 126 250 | 99 500 |

More efficient application methods

We have already dealt with this in the second application of the base coat by replacing the spray application with a pad application.



8 (i) What other steps in the process can be improved?

(ii) What would be the impact of improving transfer efficiency from 35% to 65% upon the solvent emission levels of the top coats?

(iii) Would it bring the emission concentration within the limits?

(iv) Would any other more efficient method of application bring the concentrations within the limits?

The answers to this question are on page VI:32

Reducing or replacing the solvent

Two approaches are available:

- *Nitrocellulose lacquer emulsion* in which the solvent content is as low as 15%
- *Solvent free systems*

A simple lacquer emulsion formulation is:

| | |
|---|------|
| 20% nitrocellulose emulsion (solvent content 15%) | 500 |
| Water | 500 |
| Solvent content | 7.5% |



- 9 Assume this lacquer emulsion is applied at 33g/m^2 with a spray machine operating at a transfer efficiency of 60%.

What is the effect on solvent emission concentrations?

The answer to this question is on page VI:32

Although this shows a considerable improvement in the emission concentrations from this model tannery, the concentrations are still too high for UK limits.

The only way to ensure that the concentrations fall within both UK and German limits is to use solvent-free or virtually solvent-free finishing systems.

There are a range of polymers now available as water-based emulsions, and these are mainly acrylic and polyurethane resins.

Theoretically, these resins have the necessary chemical and physical properties to meet all the requirements of a finish top coat.



- 10 (i) Can you think of any problems that could arise from the use of waterborne top coats?

(ii) Suggest possible solutions to these problems and their environmental and cost impacts:

The answers to this question are on page VI:32

Because of these problems, solvent-free coats have to be applied at a greater thickness than solvent-based coats.

Water-base formulation

| | Wt | Cost (US\$/kg) |
|-------------------|-----|----------------|
| 40% Acrylic resin | 350 | 4 |
| Organic solvent | 15 | 1 |
| Water | 635 | — |

Two coats applied by spray at a weight of 55g/m² at a transfer efficiency of 45%.



11 (i) Calculate and compare the total weekly cost for top coats using the water-based formulation as above and the original solvent formulation system.

(ii) Calculate emission concentrations of solvent in exhaust gases using the water-based system. Express your answer as total carbon.

(iii) Is this now within the control limits?

The answers to this question are on page VI:33



- 12 (i) Based on the exercises carried out, what strategy would you adopt to reduce solvent usage and emission concentrations?

- (ii) Using the material safety data sheets, compare the flash points and storage conditions of solvent-based top coats, lacquer emulsion and aqueous top coats.

- (iii) Suggest a reason for the differences between the two nitrocellulose emulsions.

- (iv) What extra storage precautions are required for the high water content top coats?

The answers to this question are on page VI:34



13 (i) Define the following:

| | |
|---------|-------|
| TWA | |
| TLV | |
| MEL | |
| OEL | |
| OES | |
| LD50 | |
| UN No. | |
| CAS No. | |

(ii) What should you conclude from the following, given on a safety data sheet?

| |
|--------------------------------------|
| Personal Protective Equipment |
| Respiratory protection: |
| Hand protection: X |
| Eye protection: X |
| Other: |

The answers to this question are on page VI:35



- 14 When using finishing materials, as a general rule, protective equipment should consist of safety glasses, gloves and overalls, worn with sensible footwear. However, the safety data sheets for each material should be checked and the protective equipment adjusted accordingly.

(i) Under what circumstances should respiratory equipment be used, and what types are available?

(ii) When should safety glasses be replaced, and by what other equipment?

(iii) Why are household rubber gloves not suitable for use with all finishing materials?

(iv) What is the first aid treatment for eye and skin contact with a crosslinker?

(v) Complete the following:

In relation to solvents and solvent-based materials, inhalation of vapours may produce:

H

and finally,

D

U

NB: solvents can also be absorbed through the skin

(vi) What is the first aid treatment for ingestion of an aqueous acrylic emulsion?

NB: When seeking medical advice, it is often beneficial to have the safety data sheet at hand, but do not waste time searching for it. These should be referred to before accidents happen, to prevent accidents.

The answers to this question are on page VI:35



15 (i) Ethylene glycol monoethyl ether (cellosolve) was used for many years as a diluent for solvent-based top coats. However, it has now fallen out of general use and has been replaced by methoxy propanol. Why?

Waste products must be separated into two types.

(ii) What are these two types?

(iii) Why are they kept separate?

(vi) What processes are normally used to dispose of them?

(v) What side effects does incineration of solvents have on the environment?

The answers to this question are on page VI:36



16 Two side effects of replacing solvent-based top coats with water-based top coats are:

- **Increased energy cost** from longer drying times or higher drying temperatures.
- **Increased waste solids** in the effluent from applying greater amounts at higher temperatures.

(i) Calculate and compare the waste solids in the solvent and water-based top coat systems going into the effluent each week.

(ii) How much more effluent would be produced if the water-based top coat systems transfer was 35%, equal to that of the solvent systems, and not 45%?

Note: disposal of solid and liquid effluent is subject to limits and limitations and the accompanying cost.

(iii) (Optional) When seeking to reduce health hazards within a workplace, the idea of the Hierarchy of Controls can be a useful concept. Place the following control measures in a hierarchy you consider the most appropriate (i.e. in order of priority):

| | |
|--|---|
| | <i>Local exhaust ventilation</i> |
| | <i>Personal protection</i> (e.g. masks, gloves etc.) |
| | <i>Substitution</i> (e.g. water-based for solvent-based) |
| | <i>Good housekeeping and personal hygiene</i> |
| | <i>Segregation</i> (keep people away from process when running) |
| | <i>Reduced time exposure</i> |

The answers to this question are on page VI:36

6.3 Answers to the work exercises

Question 1
page VI:14

(i) Solvent emissions during impregnation:

- Weight applied215g/m²
- Wastage 3%.....6.6g/m²
- Total221.6g/m²
- Solvent content 10% 22.2gm²

(ii) Solvent emissions during top coat application:

Spray application

- Weight applied33g/m²
- Transfer efficiency 35%
- Weight sprayed = 33 + 0.3594.3g/m²

Solvent content of top coat

- Nitrocellulose solution 60%..... 180gm
- Solvent 695gm
- Total 875gm
- Solvent content..... 87.5%
- Solvent used82.5g/m²

Two top coats are applied

- Total solvent used in top coat application..... 165g/m²
- Total solvent usage187.2g/m²

Question 2
page VI:14

- (i) • Solvent usage during application187.2g/m²
- Leather production..... 10 000m²/week
 - Solvent consumption per week..... 1872kg

(ii) Yes. Spray lines using organic solutions of lacquers must be cleaned using organic solvents. It is estimated that about 10% of solvent usage is used in cleaning.

(iii) Two spray coats are necessary to give the required weight of application....66g/m²
This could be achieved by one pad coat.
Spray application gives 33g/m² on the leather.

At 35% transfer efficiency:

- Amount sprayed = 33 x (100 + 35).....94.3g/m²
- Wastage = 61.3 x 2 122.6g/m²

Cost of base coat:

| | Wt US | | \$/kg |
|--------------------------|-------------|-------|------------|
| • Acrylic resin emulsion | 250 | x 2 | 500 |
| • Lead chromate pigment | 150 | x 2 | 300 |
| • Wax modifier | 50 | x 2.5 | 125 |
| • Water | 550 | | — |
| Totals | 1000 | | 925 |

Cost per kg = US\$0.925

Cost of waste = (US\$0.925 x 122.6) + 1000 per m² = \$0.1134/m²\$1134 per week

An extra drying step would also be necessary, as well as double handling costs. The efficiency of padding is given as 94% to give an application weight of 66g/m².

Weight used = 70g/m²

Cost = \$37

Question 2
Continued

(iv) Application of the second base coat layer by padding would reduce costs of wastage significantly. Waste acrylic resin and pigment from the spray coat application would be captured by the water curtain spray on the spray booth. This would then have to be disposed of as sludge.

Question 3
page VI:15

(i) The base coat contains 4.5% *lead chromate pigment*.

Lead is a known health hazard and the chromium is present as Cr(VI) a known carcinogen.

(ii) The lead chromate may be replaced by an organic pigment.

(iii) However, organic pigments have less covering power, and a spray coat application may be necessary to give the covering power. From *Question 4*, it can be seen that this would cost \$872 per week. There would also be an increase in particulate emissions to the atmosphere, solids in effluent and energy usage.

- Amount sprayed for 33g/m² deposited 33 x (100 ÷ 35)
- For 10 000m² of leather, weight sprayed in kg:
- 33 x [(100 ÷ 35) x (10 000 ÷ 1 000)] 943kg
 - Cost per kg (see *Question 2.iii*)..... \$0.925/kg
- Therefore total cost = 943 x 0.925 \$872

Question 4
page VI:15

(i) Calculations
Impregnation

Total resin applied:

- 215 x [(103 ÷ 100) x (200 ÷ 1000) x (40 ÷ 100)]..... 17.72g/m²
- Resin wasted: 17.72 x (3 ÷ 100) 0.53g/m²
- Resin applied: 17.72 – 0.53 17.19g/m²

Total solvent applied:

- 215 x [(103 ÷ 100) x (100 ÷ 1000)]..... 22.15g/m²
- Solvent wasted: 22.15 x (3 ÷ 100) 0.66g/m²
- Solvent applied: 22.15 – 0.66 21.49g/m²

Base coat

Padding

Total resin applied:

- 95 x [(106 ÷ 100) x (250 ÷ 1000) x (40 ÷ 100)]..... 10.07g/m²
- Resin wasted: 10.07 x (6 ÷ 100) 0.60g/m²
- Resin applied: 10.07 – 0.60 9.47g/m²

Total pigment applied:

- 95 x [(106 ÷ 100) x (150 ÷ 1000) x (30 ÷ 100)]..... 4.53g/m²
- Pigment wasted: 4.53 x (6 ÷ 100) 0.27g/m²
- Pigment applied: 4.53 – 0.27 4.26g/m²

Spraying

Total resin applied:

- 33 x [(106 ÷ 35) x (250 ÷ 1000) x (40 ÷ 100)]..... 9.43g/m²
- Resin wasted: 9.43 x (65 ÷ 100) 6.13g/m²
- Resin applied: 9.43 – 6.13 3.30g/m²

Total pigment applied:

- 33 x [(100 ÷ 35) x (150 ÷ 1000) x (30 ÷ 100)]..... 4.24g/m²
- Pigment wasted: 4.24 x (65 ÷ 100) 2.76g/m²
- Pigment applied: 4.24 – 2.76 1.48g/m²

Question 4
Continued

Top coat

Total resin (lacquer) applied:

- 215 x [(103 + 100) x (200 + 1000) x (40 + 100)]17.72g/m²
- Resin (lacquer) wasted: 17.72 x (3 + 100)0.53g/m²
- Resin (lacquer) applied: 17.72 – 0.5317.19g/m²

Total solvent applied: total solvent in 1000g of top coat

- 695 + [300 x (60 + 100)] 875g
- 33 x (100 + 35) x (875 + 1000)82.50g/m²
- Total solvent wasted: 82.5 x (65 + 100)53.63g/m²
- Total solvent applied: 82.50 – 53.6328.87g/m²

These results can now be inserted in the table:

| | RESIN | | | SOLVENT | | | PIGMENT | | |
|------------------------|---------|--------|-------|---------|--------|--------|---------|--------|-------|
| | applied | wasted | total | applied | wasted | total | applied | wasted | total |
| Impregnation | 17.19 | 0.53 | 17.72 | 21.49 | 0.66 | 22.15 | — | — | — |
| Base coat | | | | | | | | | |
| Padding | 9.47 | 0.60 | 10.07 | — | — | — | 4.26 | 0.27 | 4.53 |
| Spray 1 | 3.30 | 6.13 | 9.43 | — | — | — | 1.48 | 2.76 | 4.24 |
| Spray 2 | 3.30 | 6.13 | 9.43 | — | — | — | 1.48 | 2.76 | 4.24 |
| Top coat | | | | | | | | | |
| Spray 1 | 3.96 | 7.35 | 11.31 | 28.87 | 53.63 | 82.50 | — | — | — |
| Spray 2 | 3.96 | 7.35 | 11.31 | 28.87 | 53.63 | 82.50 | — | — | — |
| Total g/m ² | 41.18 | 28.09 | 69.27 | 79.23 | 107.92 | 187.15 | 7.22 | 5.79 | 13.01 |
| Total/Week kg | 412 | 281 | 693 | 792 | 1079 | 1872 | 72 | 58 | 130 |

(ii) This is a simple table to monitor usage.

| Solvent Usage Record | | | |
|---|-------------|------------------|----------------|
| Product | Amount used | *Solvent content | Solvent used |
| Impregnation resin | | | |
| Top coat A | | | |
| Top coat B | | | |
| Top coat C | | | |
| Cleaner | | | |
| Amount of leather produced per week | | | m ² |
| Solvent usage per m ² of leather | | | |

* supplied by manufacturer

These figures should be compared each week to identify any increases.

Question 5
page VI:17

- (i) • Rates of leather through spray chamber 750m²/h
 • Amount sprayed per m² (see answer to Question 1.ii) 94.3g
 • Amount sprayed per hour 70.725kg
 (of which 87.5% solvent from top coat formation)
 • Amount of solvent used per hour 61.884kg
 (of which 80% is exhausted)
 • Discharge through exhaust per hour 49.50
 (49 500 000mg)
 • Flow of air through exhaust..... 15 000m³/h
 • Concentration of solvent in exhaust = 49 500 000 ÷ 15 000..... 3300mg/m³
- (ii) • German limit 150mg/m³
 • UK limit..... 50mg/m³
 • Concentration of total carbon in exhaust = 3300 x (60 ÷ 100) 1980mg/m³
- (iii) The water curtain removes only 20% of the solvent from the exhaust gases. It cannot be considered a true arrestment method, such as incineration or adsorption.

Question 6
page VI:17

- (i) Ozone is generated and destroyed in the lower atmosphere by the following mechanism:

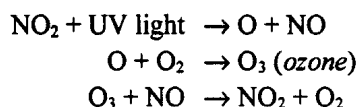

- (ii) In this way, the concentration of ozone at street level is kept low (*NB*: Do not confuse with the ozone layer in the upper atmosphere.)

Organic solvents interfere with this cycle, reacting with the nitric oxides to give peroxyacyl nitrates (CH₃ CO O NO₂). These are dangerous to health.

This reaction removes NO from the air, allowing O₃ to build up. This is dangerous to health. The mixture produced gives photochemical smog.

Question 7
page VI:18

- (i) • Amount of solvent used each year:
 15 000 x (3000 ÷ 1 000 000) x 2000 90 000kg
 • Cost of disposal at \$105/t: 105 x 90 \$9450
 • Cost of new solvent at \$1000/t: 1000 x 90 \$90 000
 • Total cost \$99 450
 • Cost of regeneration at \$250/t (100% efficient): 250 x 90 \$22 500
Regeneration is far more economical.
- (ii) • Cost of regeneration (50% efficient) \$22 500
 • Cost of additional new solvent: 100 x 45 \$45 000
 • Total cost \$67 500
Regeneration is still more economical.

Question 8

page VI:20

(i) The most obvious room for improvement lies in the application of the top coat.

There are two possibilities:

- *more efficient spray guns* (high volume, low pressure)
- *replace spray application with a roller coater.*

(ii) Since the transfer efficiency has increased, the total amount sprayed to achieve a coating of 33g/m^2 may be decreased.

- New weight sprayed: $(33 + 0.66)$ 50g/m^2
(previously $(33 + 0.35) = 94.3\text{g/m}^2$)
- Rate of leather through spray chamber $750\text{m}^2/\text{h}$
- Amount sprayed per hour (in kg): $750 \times (50 + 1000)$ 37.5kg
- Amount of solvent used per hour (solvent content 87.5%: see *Question 1.ii*)
 0.875×37.5 32.81kg
– of which 80% is exhausted 26.25kg
(26 250 000 mg)
- Flow of air through exhaust..... $15\,000\text{m}^3/\text{h}$
- Concentration in exhaust: $26\,250\,000 + 15\,000$ 1750mg/m^3
- Concentration of total carbon in exhaust: $1\,750 \times (60 + 100)$ 1050mg/m^3

(iii) This is still not within the control limits: German limit 150mg/m^3
UK limit 50mg/m^3

(iv) No. As long as the finish contains substantial amounts of solvent, the solvent must be evaporated off. Reducing the amount of waste and evaporation in the spray booth would transfer the problem to the exhaust from the drier.

Question 9

page VI:21

- Application weight 33g/m^2
 - Transfer efficiency 60%
 - New total weight applied: $33 \times (100 + 60)$ 55g/m^2
 - Rate of leather through spray chamber $750\text{m}^2/\text{h}$
 - Amount sprayed per hour: $750 \times (55 + 1\,000)$ 41.25kg
- Solvent content is 15 % of 500g in 1000g (15 + 200)
- Amount of solvent sprayed per hour: $41.25 \times (15 + 200)$ 3.09kg
 - If 80% exhausted 2.48kg
(2 480 000mg)
 - Flow of air through exhaust..... $15\,000\text{m}^3/\text{h}$
 - Concentration of solvent in exhaust: $2\,480\,000 + 15\,000$ 165mg/m^3
 - Concentration of total carbon in exhaust: $165 \times (60 + 100)$ 99mg/m^3

*This is within the German limit (150mg/m^3) but not the UK limit (50mg/m^3).***Question 10**

page VI:21

(i) Problems arise from two factors:

- The polymers are present as discrete separate particles and film formation is difficult.
- Water does not flow out into a smooth coherent film like organic solvents, due to its high surface tension.

(ii) The partial answer to both problems is to *add a coalescing agent and flow modifiers*. These are often organic solvents.

Surfactants may also be used, but these reduce the water resistance of the coatings.

Question 11
page VI:22

- (i) **Cost of water-based top coat**
- Weight applied..... 55g/m^2
 - Transfer efficiency..... 45%
 - Weight sprayed: $55 \times (100 + 45)$ 122g/m^2
 - Resin content:** $(350 + 1000) \times 122$ 43g/m^2
 - Two coats:** 86g/m^2
 - Usage per week ($10\,000\text{ m}^2$)..... 860kg
 - Cost per kg..... $\$4$
 - Weekly cost..... $\$3\,440$
 - Solvent content:** $(15 + 1000) \times 122$ 1.8g/m^2
 - Two coats:** 3.7g/m^2
 - Usage per week ($10\,000\text{ m}^2$)..... 37kg
 - Cost per kg..... $\$1$
 - Weekly cost..... $\$37$
 - Total weekly cost of water-based top coat:** $3\,440 + 37$ $\$3\,477$

Cost of solvent-based top coat

- Weight applied..... 33g/m^2
- Transfer efficiency..... 35%
- Weight sprayed: $(33 + 35) \times 100$ 94g/m^2
- Lacquer content:** $(300 + 1000) \times 94$ 28g/m^2
- Two coats:** 56g/m^2
- Usage per week ($10\,000\text{ m}^2$)..... 560kg
- Cost per kg..... $\$3$
- Weekly cost..... $\$1\,680$
- Solvent content:** $(695 + 1000) \times 94$ 65g/m^2
- Two coats:** 130g/m^2
- Usage per week ($10\,000\text{ m}^2$)..... 9.4kg
- Cost per kg..... $\$5$
- Weekly cost..... $\$47$
- Total weekly cost of solvent-based top coat:** $47 + 1\,300 + 1\,680$ $\$3\,027$

(ii) **Calculation of solvent content in exhaust using water-based system**

- Weight of top coat sprayed..... 122g/m^2
- Rate of leather through spray chamber..... $750\text{m}^2/\text{h}$
- Amount sprayed per hour (in kg): $750 + (122 + 1\,000)$ 91.5kg
- Amount of solvent used per hour: $91.5 \times (15 + 1\,000)$ 1.4kg
- of which 80% is exhausted..... 1.1kg
- (1 100 000mg)**
- Flow of air through exhaust..... $15\,000\text{m}^3/\text{h}$
- Concentration in exhaust: $1\,100\,000 \div 15\,000$ 73mg/m^3
- Concentration of total carbon: $73 \times (60 + 100)$ 44mg/m^3

(iii) This is within the German limit (150mg/m^3) and the UK limit (50mg/m^3).

The cost of the water-based top coat system is slightly higher than the solvent-based system, but expensive arrestment methods are no longer required.

Question 12

page VI:23

- (i) 1 Install system for recording solvent usage.
 2 Monitor solvent usage regularly.
 3 Investigate any increases.
 4 Replace where possible any spray application by a more efficient method.
 5 Improve efficiency of existing spraying machines:
- optimize spray pattern
 - regular checks and maintenance
 - optimize spray pressure
 - reduce re-work.
- 6 Investigate alternative low solvent or solvent-free systems for top coats.
 Remember the base coat may have to be changed as well.)
- (ii) Solvent top coats
- Enkralac clear*
- Flash point 35°C.
 - Store in separate area away from sources of ignition.
- Polyurethane M*
- Flash point 36°C.
 - Keep containers closed, store in a cool dry area away from sources of ignition, with adequate ventilation.
- Lacquer emulsion top coats
- Corial EM finish F*
- Flash point 62°C.
 - Keep tightly closed, protect from heat and freezing.
- LS 8433*
- Flash point 44°C.
 - Store in a cool, well-ventilated place, away from sources of ignition and heat. Keep containers closed.
- Aqueous top coats
- Aqualen Tops 2001 and 2002*
- Flash point none.
 - Keep container tightly closed, store product away from heat and freezing. Take care of good aeration.
- (iii) The two nitrocellulose emulsions differ greatly in flash point. LS 8433 requires similar storage conditions to the solvent top lacquers. This shows that there are differences in solvent type and content between the lacquer emulsions.
- (iv) Aqueous top coats and emulsions of high water content also need to be stored with protection from freezing, to maintain the product in a stable and useable condition.

Question 13
page VI:24

- (i) TWA Time weighted averages.
 TLV Threshold limit value.
 VOC Volatile organic compound.
 MEL Maximum exposure limits.
 OEL Occupational exposure limits.
 OES Occupational exposure standard (in COSHH Regulations) to replace OEL control limit.
 LD50 Result of acute toxicity test. Lethal dose (e.g. rat, oral) to kill 50% of the rats, the chemical being taken by mouth.
 UN No. United Nations number.
 CAS No. Chemical Abstracts Services registry number (USA)

NB: Exposure levels within the workplace are commonly measured by:

- 'Grab Sampling' (short-term exposure: minutes rather than hours) e.g. Draeger tube and sampling pump
or
- 'Badge Tests' (long-term exposure, hours) e.g. adsorption of solvent vapours onto an activated carbon 'badge' worn by the operator within the breathing zone.

(ii) Crosses on data sheets can be misleading as they indicate a positive requirement. Thus for this product, the manufacturer is stating that eye and hand protection are required. Since 'respiratory' and 'other' are left blank, this must be taken to indicate that, at the time when the data sheet was compiled, the manufacturer knew no reason for the use of respiratory or other protection when using the product.

Question 14
page VI:25

(i) Respiratory equipment should be used when spray finishing by hand, using crosslinkers or solvents without adequate localized extraction.

Several types of respiratory equipment are available:

- filtering face respirator
- half mask respirator
- full face respirator
- powered air purifying respirator
- powered visor respirator

Selection of the type of respirator must be made in accordance with materials being used – e.g. when hand spraying a finish containing a crosslinker, a self-contained breathing apparatus should be used.

(ii) Safety glasses should be replaced by goggles when working in areas where protection is required from dust and vapours and not just from splashes.

(iii) Household rubber gloves do not offer adequate protection when using solvents. They will disintegrate in certain solvents, or the solvent will penetrate the rubber. Solvent resistant gloves should be obtained.

(iv) The treatment for eye contact with a crosslinker is to wash the affected eye for at least 15 minutes under running water with the eyelids open, and then consult an eye specialist.

The treatment for skin contact with a crosslinker is to remove contaminated clothing and wash the skin with soap and water. Seek medical advice if the operator feels unwell.

(v) Inhalation of vapours produces *headaches*, *dizziness* and finally *unconsciousness*.

Question 14
Continued

- (vi) The first aid treatment for inhalation of solvent vapours is:
- to remove the patient into fresh air
 - keep them quiet
and
 - seek medical aid if exposure is prolonged, or distress is felt.
- In extreme cases, if breathing has stopped, remove the casualty to a safe area, commence artificial respiration and seek medical attention.

Question 15
page VI:26

- (i) Although methoxy propanol has a lower flash point (35°C) compared to cellosolve (49°C), in other respects it is far safer. Methoxy propanol is moderately irritating to the eyes, nose and throat, whereas cellosolve causes immediate pain to the eye, can take up to 24 hours to clear up, and is generally a more severe irritant.
- Cellosolve is not used now because of its toxic effect at very low levels on the blood, liver, kidneys, central nervous system, and the reproductive systems of both sexes. It can also be absorbed through the skin. Finally, cellosolve can react with oxidizing agents, causing explosions.
- (ii) The two types of waste product that must be kept separate are *solvent-based* and *aqueous*.
- (iii) They are kept separate by the different methods of disposal carried out by waste disposal contractors. Solvent waste is often incinerated. Aqueous waste is treated by flocculation and sedimentation prior to filtration, followed by either landfill or incineration.
- Incineration of solvents produces water and carbon dioxide. The carbon dioxide increases global warming via the greenhouse effect.

Question 16
page VI:27

- (i) Figures for usage per week are taken from *Question 11*:
- *Solvent-based top coat* (T.E. = 35%, solids = 40%): usage per week..... 560kg
Dry weight wasted: $560 \times [(65 \div 100) \times (40 \div 100)]$ 146kg
 - *Water-based top coat* (T.E. = 45%, solids = 40%): usage per week..... 860kg
Dry weight wasted: $860 \times [(55 \div 100) \times (40 \div 100)]$ 189kg
- (ii) Extra 43kg of effluent solids each week.
If T.E. = 35% equal to the solvent system then:
 $860 \times [(65 \div 100) \times (40 \div 100)]$ 224kg
Extra 78kg of effluent solids each week.
- (iii) The following is the commonly accepted hierarchy of controls:
- *Substitution*
 - *Segregation*
 - *Local exhaust ventilation*
 - *Good housekeeping and personal hygiene*
 - *Reduced time exposure*
 - *Personal protection*
- All these measures are very important and must be given careful consideration. For instance, although *personal protection* is last on list, the provision of suitable equipment is nonetheless vital.
- The point of the hierarchy is that we would seek to remove risks where possible, rather than address symptom – prevention rather than cure.*
- In practice, combinations of the control measures are often required.

6.4 Examples of chemicals used in leather finishing

6.4.1 Polymer and crosslinker examples

| Top coats | |
|----------------------------|---|
| Enkralac Clear | solvent-based nitro cellulose |
| Polyurethane lacquer M | solvent based polyurethane |
| Corial EM Finish F | nitro cellulose emulsion |
| LS 8433 | nitro cellulose emulsion |
| Aqualen Top 2001 | aqueous acrylic: can be crosslinked |
| Aqualen Top 2002 | aqueous polyurethane: can be crosslinked |
| Crosslinkers for top coats | |
| Astacin Hardener IC | |
| Aqualen AKU | |
| Crossliner 487 | |
| Base coat resins | |
| Encryl N | aqueous acrylic |
| RU 4385 | aqueous polyurethane |
| Enkrathane M2 | aqueous polyurethane: can be crosslinked for base or top coat use |

6.4.2 Solvent examples

| | |
|--------------|--|
| Ester | n-Butyl Acetate |
| Alcohol | Butanol n-Butyl alcohol |
| Ketone | Methyl Ethyl Ketone |
| Glycol ether | Ethylene Glycol Monoethyl Ether 2-ethoxy ethanol |
| | Methoxy propanol |
| Hydrocarbon | Xylene |



Part 7

References

| | | |
|------------|---|---------------|
| 7.1 | Introduction | VII:3 |
| 7.2 | References on leather tanning and finishing..... | VII:4 |
| 7.3 | Centres of expertise on leather | VII:5 |
| 7.4 | Background material on cleaner production | VII:6 |
| 7.5 | Transparencies on cleaner production | VII:14 |

7 References

7.1 Introduction

The references on leather tanning have been taken from the UNEP/UNIDO Technical Report No. 4 *Tanneries and the Environment*. The references on cleaner production have been taken from the UNEP IE training resource package *Cleaner Production*. For further information on this training resource package and a more extensive list of references on cleaner production contact UNEP IE, Paris.

7.2 References on leather tanning and finishing

- UNIDO [1979] *Information Sources on Leather and Leather Product Industries*. United Nations.
- Urwick Technology Management Ltd [1977] *Environmental Impacts and Policies for the EEC Tanning Industry*. Graham and Trotman Ltd, for the Commission of the European Communities.
- Ahmad, J. (Ed.) [1982] *Environmental Guidelines for the Hides and Skin Industry*. Environmental Guideline Series. Nairobi: UNEP.
- Carre, M.C.; Vulliermet, A.; Vulliermet, B. [1983] *Environmental and Tannery*. Lyon, France: Centre Technique du Cuir.
- Department of Environment [1978] *Wastes from Tanning, Leather Dressing and Fellmongering*. Waste Management Paper No. 17. London: HMSO
- ESCAP [1982] *Industrial Pollution Control Guidelines Part VII: Tanning Industry*. Environment and Development Series. Bangkok: United Nations.
- Lollard, R.M. [1985] *Issues and Opportunities in Tannery Chromium Management*. Boston, USA: L.I.A.
- Sykes, R.L.; Corning, D.R. [1987] 'Pollution Abatement and Control in the Leather Industry' in *Industry and Environment* 10(2)pp9-22. UNEP/IEO.
- Covington, A.D. [1989] 'Ecological Pressures Force Change: Alternative Tanning Techniques' in *World Leather* 1(8)pp10-14.
- Howie, I. [1989] 'The Wet-White Option' in *World Leather* 2(4)pp110-115.
- Spahrman, J. [1979] 'Direct and Indirect Recycling of Tannery Waste Water' in *Journal of the American Leather Chemical Association* 74(11)pp418-421.
- Vulliermet, B. [1980] 'Improvements of the Mass and Energy Balances in the Tanning Industry' in *Journal of the American Leather Chemical Association* 75(7)pp233-286.

7.2.1 General leather finishing

- Prof.E. Heidemann [1993] *Fundamentals of Leather Manufacturing* Chapter 18. Edward Roether KG.
- BASF *Leather Finishers Manual*.

7.2.2 Application methods

- J. Biles; N. Di Candilo, P. Gehlaus; W. Prentiss [1985] *JALCA* 80 284.
- Helmut Will [1985] *JALCA* 80 293.
- BASF [1990] *Leather in Asia* Oct-Dec 28.
- Devilbiss Rausburg [1991] *World Leather* Aug-Sept 32.
- G. Maritan; G. Tadiello [1994] *World Leather* June-July 31.

7.2.3 Water based coatings

- J.J. Biles; N.J. Di Candilo; W.C. Prentiss [1987] *JALCA* 82 65.
- F.A. Pules [1990] *World Leather* April-May 56.
- F.A.D. Pulles [1990] *PLTJ* July-Sept 71.
- J. Biles [1990] *JALCA* 85 163.
- W. Wenzel [1991] *JALCA* 86 442.
- G. Ecbert [1991] *Leather* August 14.
- H. Will; K. Fischer [1991] *JALCA* 86 49.
- C.J. Gill [1992] *JALCA* 87 82.
- C.J. Gill [1991] *JALCA* 86 42.
- C.J. Gill [1993] *JALCA* 88 197.
- F. Zsilavec [1993] *Leather* October 17.
- G. Tadiello [1993] *Leather Manufacturer* Oct.

7.3 Centres of expertise on leather

BLC The Leather Technology Centre

Leather Trade House, Kings Park Road
Moulton Park, Northampton NN3 6JD
United Kingdom

Tel 00 44 1604 494 131

Fax 00 44 1604 648 220

Centro de Investigacion de

Tecnologia del Cuero (CITEC)

(Leather Technical Research
Centre)

Camino Centenario 505 & 508,
1897 Gonnet, Argentina

Tel 00 54 84 1876 La Plata

Fax 00 54 84 0244

CSIRO

Leather Research Centre

Bayview Avenue, Private Bag 10
Clayton, VIC 3168, Australia

Tel 00 61 3 542 22 44

Fax 00 61 3 542 23 66

Centro Tecnológico de Couro (SENAI)

(Centre of Leather Technology of SENAI)

Rua Gregorio De Mattos 111

93600-000 Estancian Velha, RS, Brazil

Tel 00 55 56 11 610

Fax 00 55 51 56 11 864

Centre Technique Cuir

Chaussure Maroquinerie (CTC)

(Leather Technical Centre)

Parc Scientifique Tony Garnier

4 rue Hermann Frenkel, F-69367

Lyon Cedex 7, France

Tel 00 33 04 72 76 10 10

Fax 00 33 04 72 76 10 00

Westdeutsche Gerberschule Reutlingen (WGR)

West German Tanners School of Reutlingen

Postfach 29 44, D-72719 Reutlingen, Germany

Tel 00 49 71 21 16 23-0/35

Fax 00 49 71 21 16 23 11

Central Leather Research Institute (CLRI)

Adayar, Madras 600 020, India

Tel 00 91 44 412 868

Fax 00 91 44 491 1589

Secja Garbarska przy Polskim

Towarzystwie Chemicznym

(Tanner's Section of Polish Chemical Society)

c/o Leather Research Institute, Zgierska 73

PL-90960, Lodz, Poland

Tel 00 48 42 576 210

Fax 00 48 42 57 62 75

Leather Industries Research Laboratory

University of Cincinnati, PO Box 210 014

Cincinnati OH 45221-0014, USA

Tel 00 1 513 556 1200

Fax 00 1 513 556 2377

Shanghai Leather Industry Research Institute

No. 747 Xie Tu Road

200023 Shanghai, China

Tel 00 359 21 43 14 614

United Nations Industrial

Development Organization (UNIDO)

Agro Based Industries Branch

Industrial Sectors & Environment Division

Vienna International Centre, PO Box 300

A-1400 Vienna, Austria

Tel 00 43 1 21131

Fax 00 43 209 7662

7.4 Background material on cleaner production

7.4.1 Publications available from UNEP

Audit and Reduction Manual for Industrial Emissions and Wastes [1991] UNEP IE and UNIDO. Technical Report No 7.

The manual is a practical working document intended for use within industry.

It can be used by:

- factory personnel at all levels interested in upgrading their own processes
- consultants reporting to an industrial client
- government personnel reviewing existing factory operations.

127pp., price: FF200/US\$40.

Cleaner Production Worldwide [1993]

This publication aims to show through examples that by applying Cleaner Production, industry and consumers anywhere in the world can gain environmental benefits while reducing costs. Free of charge.

Climate Change and Energy Efficiency in Industry [1990] (a joint UNEP IE-IPIECA publication). 64pp., free of charge.

Government Strategies and Policies for Cleaner Production [1994]

This report explains how cleaner production leads to economic benefits as well as environmental ones, and why it is the best way of fulfilling Agenda 21. It offers advice on effective strategies and describes some of the instruments that governments and large industries can use when implementing cleaner production policies. 32pp.

Storage of Hazardous Materials [1990]

Practical guidelines for the safe storage and warehousing of hazardous materials to encourage safer practices in both developed and developing countries. Technical Report No 3, price: FF180.

Tanneries and the Environment [1991]

Technical Report No. 4

119pp., price: FF200/US\$40.

7.4.2 Some background documents on the environment

Saving Our Planet: challenges and hopes [1992]

M.K. Tolba (Executive Director of UNEP).

ISBN 0 412 47370 4.

This book analyses the changes that have occurred in the environment in the past two decades. It focuses not only on the state of the environment, but also on the interactions between development activities and the environment. It highlights the main responses since 1972 to protect the environment.

Published by: Chapman & Hall,

2-6 Boundary Row, London SE1 8HN, UK.

Environmental Data Report 1993-1994 [1993]

United Nations Environment Programme.

ISBN 0 631 19043 0.

This report is updated biennially and provides the best available data and information on a wide

range of environmental topics, including pollution, health, natural resources, population and settlements, energy, wastes and disasters.

Published by: Blackwell Publishers,

108 Cowley Road, Oxford OX4 1JF, UK.

Chemical Pollution: a global overview [1992]

United Nations Environment Programme.

This book overviews the origins and impacts of pollution around the world, caused by selected chemical pollutants and wastes.

Published by: UNEP, Nairobi.

The Earth Summit's Agenda for Change: a plain language version of Agenda 21 and the other Rio Agreements [1993] M. Keating. ISBN 2 940070 00 8.

This publication is aimed at facilitating access to the very important material contained in Agenda 21.

Published by:

The Centre for Our Common Future,
52 rue des Paquis, 1201 Geneva, Switzerland.

Beyond the Limits: *global collapse or a sustainable future?* [1992] D.H. Meadows;
D.L. Meadows; J. Randers. ISBN 1 85383 131 X.

Using World 3, a computer model, to project the future, and by varying the basic global policy assumptions, a range of possible outcomes is described. It is shown that a sustainable society is technically and economically feasible, if growth in material consumption and population are ceased and there is an increase in the efficiency of our use of materials and energy.

Published by: Earthscan Publications Ltd.,
120 Pentonville Road, London N1 9JN, UK.
Changing Course: a global business perspective on development and the environment [1992]
S. Schmidheiny. ISBN 0 262 69153 1.

This book provides an analysis of how the business community can adapt and contribute to the crucial goal of sustainable development, combining the objectives of environmental protection and economic growth.

Published by: Massachusetts Institute of
Technology (MIT) Press, Cambridge,
Massachusetts 02142, USA.

Blueprint for Green Management: creating your company's own environmental action plan [1995]
G. Winter. ISBN 0 07 709015 2.

This book is a handbook of industrial ecology with numerous checklists for practical use and a concrete example of the Integrated System of Environmental Business Management (the so-called Winter Model), supported by the Commission of the European Communities.

Published by:

McGraw-Hill Book Company (UK) Ltd.
Life Cycle Assessment: what it is and how to do it [1996] UNEP IE

This report is in two parts. The first, *Life Cycle Assessment: what it is*, is concerned with the concept of LCA, how it is currently practised and how it is expected to develop. It also places LCA in the broader perspective of other tools for environmental analysis such as environmental impact assessment, risk analysis and technology assessment.

The second part of the volume, *Life Cycle Assessment: how to use it*, examines the several steps involved in making an LCA in a simplified but systematic manner. It illustrates the problems involved and the kind of results that can be produced by working through a real LCA that has been used to assess the environmental impact of different low fat spreads.

Further information: UNEP IE, Paris, France.

7.4.3 Books and manuals on cleaner production

The United States Environmental Protection Agency (US EPA) publishes many cleaner production (US EPA uses pollution prevention) documents. Most of them are free.

Further information: **Pollution Prevention Information Clearinghouse**, US EPA,
401 M Street, SW. PM-211A, Washington D.C. 20460, USA.
Tel. (1 202) 260 1023; Fax. (1 202) 260 0178.

Curriculum for toxics use reduction planners
[1994] Sixth edition.

The curriculum is designed to encourage participants to re-examine conventional approaches to production management and environmental protection. The manual is intended to serve as the basis for an advanced educational program for the training of Toxics

Use Reduction Planners. The targeted audience are technically experienced professionals and production managers.

Further information: Toxic Use Reduction
Institute, University of Massachusetts at Lowell.
One University Ave., Lowell,
Massachusetts 01854.

Facility Pollution Prevention Guide [1992].

The guide is written for those who are responsible for implementing pollution prevention in their facilities. It is intended to help small- to medium sized production facilities develop broad-based, multimedia pollution prevention programmes. It describes how to identify, assess, and implement opportunities for preventing pollution and how to stimulate the ongoing search for such opportunities.

Further information: US Environmental Protection Agency, Office of research and Development, Washington, DC 20460. Document number: EPA/600/R-92/088.

Hazardous Waste Minimization [1990]

H. M. Freeman.

This book is designed to assist individuals in private companies and public agencies in identifying and pursuing options for waste minimization.

Published by: McGraw-Hill Publishing Company. ISBN 0 07 022043 3.

Pollution Prevention: Homework & design problems for engineering curricula [1992]

D. T. Allen, N. Bakshani, K. Sinclair Rosselot.

The book is designed to be integrated into existing courses leading to chemical and other undergraduate engineering degrees. However, the manual has proved useful to others in industry and environmental fields, as well.

Published by American Institute of Chemical Engineers Center for Waste Reduction Technologies.

ISBN 0-8169-058-1-9.

Available from: AIChExpress Service Center, 2345 East 47th Street, New York, NY 10017-2395, 1-800-ALChemE; fax: 212 705 8400.

Prepare [1991] Editors: S. de Hoo, H. Brezet, M. Crul, H. Dieleman.

The *Prepare* box includes a video, a manual for the Prevention of Waste and Emissions, Prevention of waste and emission worksheets, and the Prepare Experience binder. The package focuses on exploring the opportunities to prevent waste and emissions that are present within existing companies. It is a source of ideas for the development and bringing into practice of a waste and emission prevention programme. Published by the Dutch Ministry of Economic Affairs.

Available from: SDU/DOP, Rooseveltstraat 52-56, 2321 BM Leiden, The Netherlands. Tel. (31 71) 352 500.

Prosperity without Pollution: the prevention strategy for industry and consumers [1991]

J. S. Hirschhorn, K.I. Oldenburg.

This book explains why only the preventive environmental strategy can work, because growing population, consumption, and industrialization cripple current remedial efforts.

Published by: Van Nostrand Reinhold; 115 Fifth Avenue, New York, NY 10003. ISBN 0 442 00225 4.

Training Course: Ecologically Sustainable Industrial Development.

This training kit contains ten separately bound Learning Units, a video cassette with seven films, two floppy discs, an audio cassette and, for supplementary reading, two booklets and a manual. The training course is designed for UNIDO staff, but it is suitable for all staff of the United Nations as well as for anyone interested in industrial development.

Available from: UNIDO, Environment Coordination Group, P.O. Box 300, A-1400 Vienna, Austria.

7.4.4 Journals and newsletters

Cleaner Production The Newsletter of the UNEP IE network dedicated to promoting cleaner production. Appears twice a year. Subscription free. For subscription, write to UNEP IE, Paris, France.

EIA Newsletter Newsletter on activities and development in the field of Environmental Impact Assessment. It is written for, and by, participants in an EIA network which covers 72 countries. *Subscription information:* EIA Centre, Department of Planning and Landscape, University of Manchester, Manchester M13 9PL, United Kingdom.

Environmental Technology Assessment

Newsletter of the Environmental Technology Assessment (EnTA) Programme of UNEP IE.

The newsletter is produced twice a year.

Further information: UNEP IE, Paris, France.

Green Product Design Newsletter of the section for environmental product development, Faculty of Industrial Design Engineering, Delft University of Technology. *Subscription information:* Green Product Design, Jaffalaan 9, 2628 BX, Delft, The Netherlands. *Tel* (31 15) 782 738; *Fax* (31 15) 782 956.

Industry and Environment Quarterly review, which provides a forum for the exchange of research and experience, presenting articles written by and for industry managers, government officials and researchers in the field of sustainable development.

Subscription: US\$45/year (surface mail), US\$55/year (air mail). UNEP IE.

For subscription, write to UN Bookshop/Sales Unit, Palais des Nations, CS 1211 Geneva 1^W, Switzerland.

Journal of Cleaner Production A quarterly journal devoted to technologies, concepts, and policies for pollution prevention, waste minimization and Cleaner Production. Subscription: £125 (Europe), £135 (rest of world). *Further information:* Turpin Distribution Services Ltd, Blackhorse Road, Letchworth, Herts, SG6 1HN, UK.

Journal of Clean Technology and Environmental Sciences A quarterly international journal devoted to pollution prevention and clean technology. Published by the International Association for Clean Technology, which aims

to promote the research and application of clean technologies and methodologies. Annual membership of IACT includes a subscription to the journal of Clean Technology and Environmental Science, the IACT Newsletter, and access to the IACT Information Network (85 US to 250 US). *Further information:* IACT Secretariat, Rechte Wienzeile 29/3, A 1040 Vienna, Austria. *Tel* (43 1) 567 487; *Fax* (43 1) 314 182.

Loss Prevention Bulletin Appears six times per year. Contains articles and case histories from process industries throughout the world.

Subscription: £50 per year for universities.

Subscription information: The Editor, Loss Prevention Bulletin, Institute of Chemical Engineers, 165-171 Railway Terrace, Rugby, CV21 3HQ, England.

Pollution Prevention European Edition. A journal for the protection of the Environment, which is published seven times a year. Published by: MacDonald Communications, Inc. Subscription US\$90/year. *Further information:* Pollution Prevention, 90 Long Lane, Rickmansworth, Herts WD3 2YG, UK.

Pollution Prevention News Quarterly newsletter of the US Environmental Protection Agency. To be added on the mailing list, write: Pollution Prevention News, US EPA, 401 M Street SW (MC 7409), Washington, DC 20460, USA.

Pollution Prevention Review Quarterly journal aimed at a wide range of readers. Each issue contains topics of current interest in pollution prevention, covering such areas as education, model programs, implementation techniques, and regulatory developments. *Subscription information:* Executive Enterprises Publications Co., Inc., 22 West 21st Street, 10th Floor, New York NY 10010 6904.

Tel (1 212) 645 7880, extension 208.

The Hazardous Solid Waste Minimization & Recycling Report Monthly newsletter on pollution prevention published by Government Institutes, Inc. *Subscription:* US\$252/year. *Subscription information:* Government Institutes, Inc., 4 Research Place, Suite 200, Rockville, MD 20850, USA.

Waste Notes A publication of the Centre for Waste Reduction Technologies (CWRT) of the American Institute of Chemical Engineers. *Subscription information:* Centre for Waste Reduction Technologies, 345 East 47th Street, New York, NY 10017-2395. *Fax* (1 212) 752 3297.

Waste Reduction Bulletin A monthly periodical for industry promoting hazardous waste reduction. *Subscription information:* Ontario Waste Management Corporation (OWMC), 2 Bloor St. West, 11th Floor, Toronto, ON, M4W 3E2, Canada.

7.4.5 Databases and information sources

Central European Environmental Data Request Facility (CEDAR) International Society for Environmental Protection.

CEDAR provides the environmental and scientific community in Central and Eastern Europe (CEE) with state of the art access to environmental information located throughout the world.

Marxergasse 3/20, A-1030, Vienna, Austria.
Tel (43-1) 715 58 79; fax (43-1) 715 28 29.

The Centre for Environmental Management and Planning (CEMP) undertakes research, training, consultancy and the provision of environmental information services on many aspects of environmental management and impact assessment.

Further information: CEMP, AURIS Environmental Division, 23 St Machar Drive, Old Aberdeen, AB2 1RY, Scotland, UK.
Tel (44 224) 272 483; fax (44 224) 487 658.

Environmental Impact

Assessment Centre (EIA Centre)

The Centre's functions are:

- to undertake research and other studies relating to EIA
- to undertake, and assist others to undertake, EIA educational and training programmes
- to provide advice to those engaged in implementing EIA.

Further information: EIA Centre, Department of Town and Country Planning, University of Manchester, Manchester, M13 9PL.

The Global Environmental Technology Network (GETNET) is a network established by the World Health Organization (WHO).

The activities of the network include:

- information exchange
- development of training activities
- research promotion

– intersectoral cooperation.

Further information: Environmental Technology Division of Environmental Health, World Health Organization, 1211 Geneva 27, Switzerland.

Tel (41-22) 791 375 4; *Fax* (41-22) 791 07 46.

International Association For Impact Assessment (IAIA)

Further information: IAIA Executive Office, PO Box 70, Belhaven, NC 27810, USA.

Tel (1 919) 964 2338; *fax* (1 919) 964 2211.

Industrial and Technological Information Bank (INTIB) is the United Nations Industry and Development Organization's clearinghouse.

Its main task is to provide industry in developing countries with the necessary background for sound technological and business decisions. INTIB has information on clean technology and industrial energy saving, as well as other relevant data.

Further information: Chief, Industrial and Technological Information Bank, UNIDO, PO Box 300, A-1400, Vienna, Austria.

International Register of Potentially Toxic Chemicals (IRPTC) is an international Clearinghouse for scientific, technical and regulatory information for assessment and control of chemical hazards.

It operates a global network for exchange of information, operates a databank and provides a query response service.

Further information: The Director, IRPTC/UNEP, Palais des Nations, 1211 Geneva 10, Switzerland.

Tel (41-22) 798 8400/5850;
fax (41-22) 733 2673.

Organization for Economic Cooperation and Development (OECD) is active in environment economics, management and research and has many publications.

It has a programme on technology and the environment that focuses on the promotion of cleaner technology.

OECD, 2 rue André Pascal, F-75775 Paris, Cedex 16, France. Tel (33-1) 45 24 82 00; Fax (33-1) 45 24 85 00.

Ontario Waste Management Corporation (OWMC)
Waste Characterization Database.
2 Bloor St. West, 11th floor, Toronto, ON, M4W 3E2, Canada.

7.4.6 Audiovisuals

A number of videos are available concerning Cleaner Production and waste prevention. Most of these have been produced for specific national programmes in Canada, the Netherlands, the USA and elsewhere. Their use in general programmes on Cleaner Production must take these national origins into account.

Films marked with an asterix () are available for viewing only at UNEP IE in Paris.*

An Introduction to Leather (*No 51)

Language English *Year* 1996

Length 18.5 minutes

Distributed by: British Leather Confederation, Leather Trade House, Moulton Park, Northampton NN8 1JD.

Tel (44-604) 494 131; Fax (44-604) 648 220.

Summary: This video introduces the non-specialized audience into the different phases of leather tanning, from the beamhouse to leather finishing.

Cleaner Production: the bottom line

Language English *Year* 1994

Length 15 minutes

Produced by: The Australian National University, Instructional Resources Unit, for the Commonwealth Environmental Protection Agency.

Distributed by: Public Affairs & Education Section, 40 Backall Street, Barton ACT 2600, PO Box E305, Queen Victoria Terrace, ACT 2600 Australia.

Tel (63-06) 274 1999; fax (63-06) 274 1666.

Cleaner Production: the green line

Length 15 minutes

See *Cleaner Production: the bottom line*.

Cleaner Technology: the way to a better environment

Language English *Year* 1992

Produced by: Lars Brydesen Film

Distributed by: Lars Brydesen Film, Lochersvej 15, 3100 Hornbaek, Danmark.

Tel (45-45) 22 002 84; Fax (45-45) 87 27 05.

Money Down the Drain (*Nos 83 & 138)

Language English *Year* 1986

Length 17 minutes

Produced and distributed by: Ontario Waste Management Corporation (OWMC), 2 Bloor St. West, 11th Floor, Toronto, ON, M4W 3E2, Canada.

Summary: This video presents four examples of Cleaner Production initiatives that reduce costs, too. Suitable for a technical audience.

Pollution Prevention (*No 162)

a) PPRB Research Programmes

b) *Less is More: pollution prevention is good business*

c) *In Partnership with Earth: the future of the environment*

d) *Beyond Business As Usual: meeting the challenge of hazardous waste*

e) *Rinsing Process Modifications for Metal Finishers*

Language English *Year* 1993

Length a) 23 minutes; b) 23 minutes

c) 60 minutes; d) 28 minutes 30 seconds

e) 30 minutes

Produced and distributed by: US EPA, Cincinnati, Ohio 45268

Summary: This videotape contains five pollution prevention films produced by various EPA organizations, and was put together by the Pollution Prevention Research Branch (PPRB) of the EPA's office of Research and Development. The films promote pollution prevention by highlighting selected success stories from both industry and the public sector.

The Competitive Edge (*No 84)

Language English *Length* 17 minutes

Produced by: OWMC Canada

Distributed by: Ontario Waste Management Corporation (OWMC), 2 Bloor St. West, 11th floor, Toronto, ON, M4W 3E2, Canada.

Summary: This video explains the purpose of and the major steps in a waste audit. Good teaching material. Specialist audience.

Waste Minimization

Language English *Year* 1994

Length 22 minutes

Produced and distributed by: Andrew Bailey and Cinewessex. Copies can be obtained from: Dr N. Johnson, CEST, 5 Berners Road, Islington, London N1 OPW.
Fax 44 171 354 4301.

Summary: This video shows the results of the world's largest waste minimization initiatives: Project Catalyst and the Aire and Calder Project.

For further film information, contact:

The Film Librarian, Audio Visual Unit, Information & Public Affairs (IPA),

UNEP PO Box 30552, Nairobi, Kenya

Tel: (254-2) 23 00 84/23 08 00

or

UNEP IE, Tour Mirabeau, 39-43 quai André Citroën,
75739 Paris Cedex 15, France

Tel: (33-1) 44 37 14 50; *Fax:* (33-1) 44 37 14 74.



IChemE has an international reputation for providing high quality, effective safety and environmental training solutions using video, slide, open learning and computer-based techniques. We draw on experts throughout industry, the regulatory bodies, the legal profession and academia to ensure that our training packages are both high quality and relevant.

7.4.7 Environmental packages

ENVIRONMENTAL AWARENESS

Package E02

Understanding is the key to effective environmental improvements - both through certified standards and effective policy implementation. This package gives a thorough grounding in environmental awareness. The case studies cover: environmental law; global issues; corporate issues; and waste minimization.

AQUEOUS EFFLUENTS

Volume 1: awareness and treatment strategies

Package E01

Engineers learn how to assess and deal with effluent problems; senior management gain a sound technical and legal grounding; and operators learn why compliance is important. Seven case studies demonstrate how effective treatment strategies save money whilst benefiting the environment. And the technical guidance covers: characterisation of effluents; treatment strategy; safety; unit operations; and costs.

Volume 2: measurement and monitoring

Package E013

Trainees learn how to measure and monitor effluents, ensuring compliance and reducing treatment costs.

AIR EMISSIONS

Volume 1: key issues

Package E03

This package provides comprehensive coverage of generic air pollution issues and technologies, backed up with detailed sections on sources and types of emissions, atmospheric chemistry, standards and legislation (UK and European).

Volume 2: monitoring and control

Package E012

This package follows on from AE Vol. 1: key issues, and provides detailed information on measurement and monitoring and control techniques, illustrated with comprehensive case studies. Sections on ambient monitoring, meteorology and air dispersion modelling help to provide a thorough grounding in the technical issues associated with air emissions.

ENERGY MANAGEMENT

Package E011

Energy efficiency affects the bottom line. Trainees learn the basic tools and techniques for effective energy management.

ENVIRONMENTAL AUDITING

Package E04

Trainees learn how to make audits more effective. In clearly defined sections, the package explains how to go about auditing a site, from defining the scope and objectives through on-site activities to reporting and follow-up work. Thirteen case studies and exercises, supported by over 120 slides, include: setting up an EMS; auditing for waste disposal, due diligence and effluence compliance; reporting audit findings; and discussion of photographs of bad practice.

ENVIRONMENTAL MANAGEMENT SYSTEMS

Package E05

If you already have an environmental management system, this package will help you gain commitment from your staff. If you are just developing a system, not only will you benefit from the training, but also benchmarking from the detailed case studies will save you time. And if you have still not decided which system to go for (if any), this package will help you make an informed decision.

ENVIRONMENTAL IMPACT ASSESSMENT

Package E06

This training package gives you a thorough grounding in the EIA process and techniques. Produced in conjunction with the Institute of Environmental Assessment, the package provides an effective means of training all staff concerned with EIAs. There are nine case studies provided by leading environmental consultancies. These introduce the practical aspects of the EIA process by examining projects involving a food processing plant, a sewage treatment works, a coastal defence scheme, a pipeline proposal, an oil refinery and a power station.

WASTE MINIMIZATION

Package E07

Approaches in the package vary from good housekeeping to complex techniques such as life cycle analysis. This training package shows how to go about it, from defining a strategy through to making sure it happens.

CONTAMINATED LAND

Package E08

Trainees learn why contaminated land is important, how and why a company should avoid contamination, and the pros and cons of the key remediation techniques. You will also learn how to use this knowledge to get the most out of the consultants you use.

For order form contact:

Mark Smith

Safety Health and Environment Department • Institution of Chemical Engineers
165-189 Railway Terrace • Rugby CV21 3HQ, UK

Tel +44 1788 578214 • Fax +44 1788 560833

7.5 Transparencies on cleaner production

In order to allow trainers to introduce the work exercises, a number of transparencies are included here. A more complete set can be found in the Trainers Package *Cleaner Production*.

Cleaner Production means ...

“The continuous application of an integrated preventive environmental strategy to processes and products so as to reduce risks to humans and the environment”

This definition of Cleaner Production is used by UNEP IE. It is based on the assumption that there is no such thing as clean production. Every production process results in some form of pollution. The Cleaner Production approach tries to continuously reduce the generation of pollution, at every stage of the life cycle.

There are also different definitions being used by other organizations.

Don't mistake Cleaner Production for *Waste Minimization*, *Pollution Prevention* and so on.

Cleaner Production puts a heavy emphasis on attitude change!

For *processes*, this means ...

- *conserving* raw materials and energy
- *eliminating* the use of toxic raw materials
- *reducing* the quantity and toxicity of all emissions and wastes before they leave a process

For *products*, this means ...

- *reducing* impacts along the entire life cycle, from raw material extraction to disposal.

This transparency explains in more detail what Cleaner Production means.

**Cleaner Production
lowers the *risks* to:**

- *the workers*
- *the community*
- *consumers of
products*
- *future generations*

This transparency, together with the two which follow, explains the benefits of Cleaner Production. These arguments are important to overcoming the barriers to convincing people to adopt Cleaner Production practices.

**Cleaner Production
lowers the *costs* of:**

- **production**
- **end-of-pipe
treatment**
- **health care**
- **cleaning up the
environment**

Demonstrating how Cleaner Production is cost effective, and can even reduce costs, is a powerful argument!

Cleaner Production *improves:*

- **process efficiency**
- **product quality**

Even when investment costs are *high*, the payback period can be *low*.

There is *no* payback period on end-of-pipe investments.

The cost argument can be supported by the efficiency and product quality argument. Cleaner Production makes economic sense.

Some important statistics ...

Over

50% of *waste*

can be avoided by
*simple management
measures* and *minor
process changes*

Over

65% of the *barriers*

to cleaner production
involve
*human motivation
and attitudes!*

The majority of the barriers have nothing to do with economics or cost effectiveness.

What is a Waste Audit?

A Waste Audit is ...

- an *analytical tool* designed to assure industrial managers that their organization is operating in an environmentally safe and economically efficient manner
- used to *document* the types and quantities of wastes generated by the firm
- a *systematic approach* to the identification and evaluation of various Cleaner Production options

The waste audit is a systematic approach to Cleaner Production. This assessment follows a specially developed procedure which is discussed in detail in the following transparencies. For more details of how the procedure works, refer to the UNEP/UNIDO Technical Report No. 7 *Audit and Reduction Manual for Industrial Emissions and Wastes*.

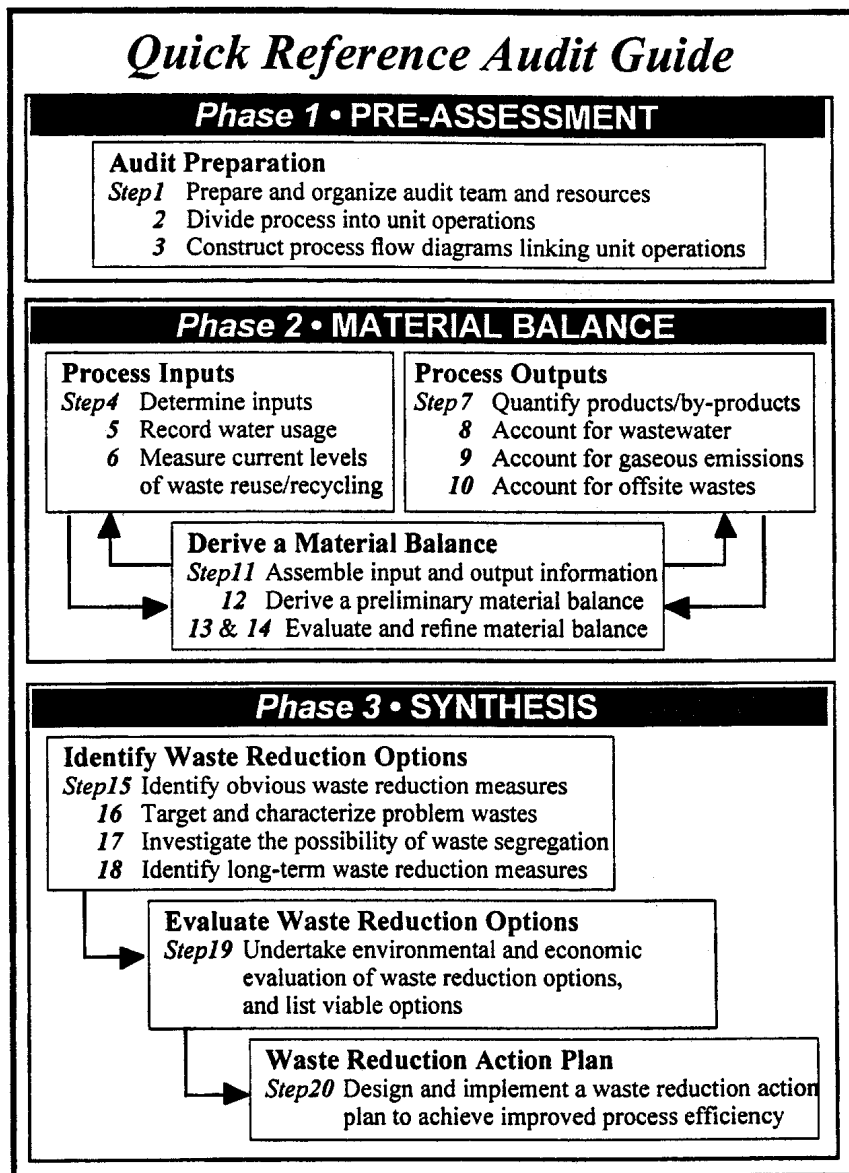

The waste audit, whose outlines are shown here, is discussed in more detail in the technical background paper and in the UNEP/UNIDO technical report *Audit and Reduction Manual for Industrial Emissions and Wastes*. There are several procedures developed for waste audits (sometimes called Waste and Emission Prevention Assessment, Source Reduction Audit, Waste Minimization Audit, or Cleaner Production Assessment). The UNEP IE publication *Government Strategies and Policies for Cleaner Production* discusses some of the alternative waste procedures.

Company Data for a Waste Audit

General Information

- Company environmental policy documents
- Standard procedures
- Organization charts

Raw Materials/Product Information

- Product composition and batch sheets
- Overviews of raw materials and input material applications (including energy)
- Fact sheets on product safety aspects
- Product and raw material inventory records
- Operator data logs
- Operating procedures
- Production schedules

This transparency, together with the two which follow, gives a checklist of the information you need when preparing the assessment of waste streams. Depending on your audience, it may be interesting to go into more detail about these sources of information.

Company Data for a Waste Audit *continued ...*

Process Information

- Production process flow diagrams
- Materials and heat balances (both in theory and in practice) for:
 - production processes
 - waste treatment processes
- Manuals and descriptions of the production process
- Installation overviews
- Specifications of installation and data sheets
- Diagrams of pipes and instruments
- Site and buildings drawings
- Installation layout and logistics

See previous transparency for comment.

Company Data for a Waste Audit *continued ...***Environmental Data**

- Emission records
- Analyses of waste materials
- Environmental audit reports
- Licences and/or licence applications

Financial Data

- The cost of waste treatment, waste removal, and effluent costs
- Product, utility and raw material costs/cost price composition of products
- Operating and maintenance costs
- Financial reports

See previous transparency for comment.

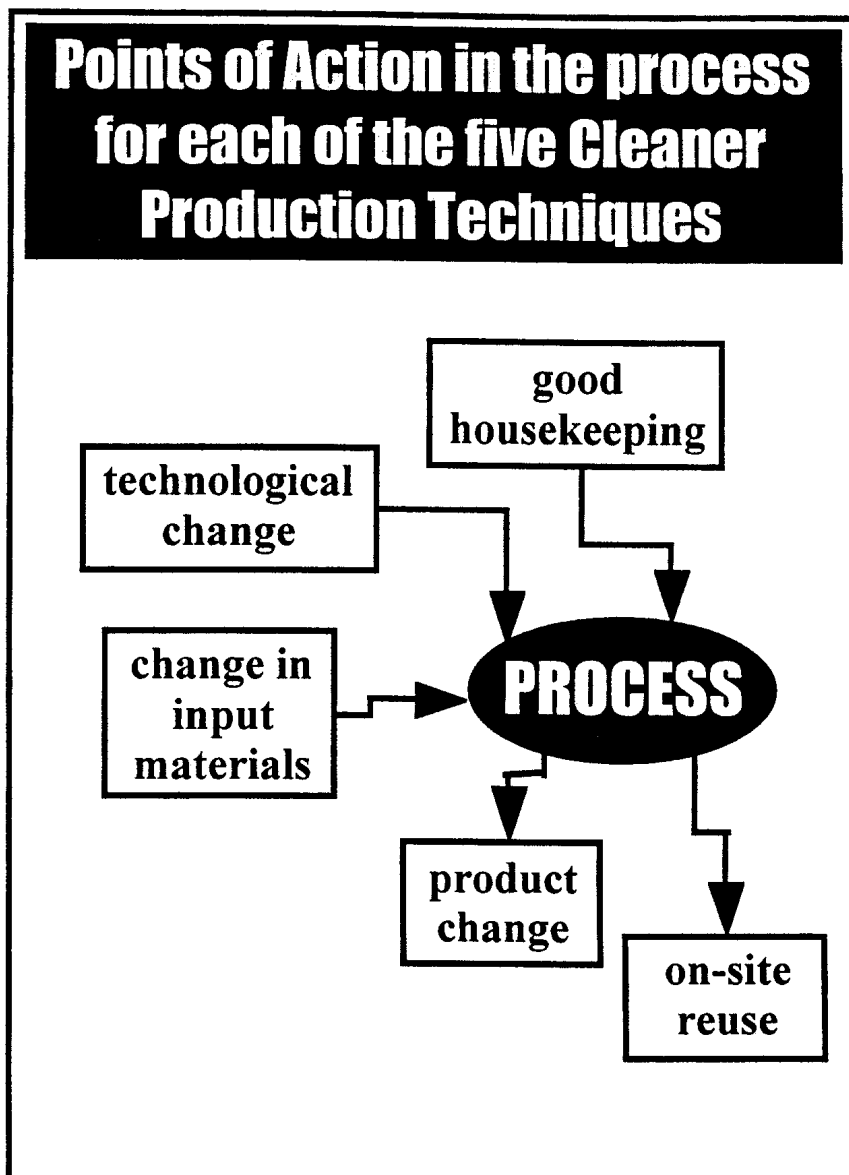

Based on the five features that influence the environmental performance of a process, these points of action can be taken to improve the environmental performance of the process.



Annexes

| | | |
|------------------|--|-----------|
| <i>I</i> | Process Guidance Notes on Leather Finishing | 3 |
| <i>II</i> | Examples of Health and Safety Data Sheets for Chemicals.. | 17 |

Annex I

Process Guidance Notes on Leather Finishing

Department of the Environment
The Scottish Office
Welsh Office

Environmental Protection Act 1990, Part I

Processes prescribed¹ for air pollution control by Local Authorities

Secretary of State's Guidance – Leather finishing processes

This Note is issued by the Secretary of State as a guide to local authorities on the techniques appropriate for the control of air pollution in relation to leather finishing processes in order to achieve the objective set down in section 7(2)(a) of the Environmental Protection Act 1990. It will also be of interest to operators of such processes. The objective in section 7(2)(a) is:

“ensuring that, in carrying on a prescribed process, the best available techniques not entailing excessive cost (BATNEEC) will be used:

- (i) for preventing the release of substances prescribed for any environmental medium into that medium or, where that is not practicable by such means, for reducing the release of such substances to a minimum and for rendering harmless any such substances which are so released; and*
- (ii) for rendering harmless any other substances which might cause harm if released into any environmental medium”.*

By virtue of section 7(5) of the Act local authorities only have control over emissions into the air under Part I of the Act.

¹As prescribed under Section 2:1 of the Environmental Protection Act 1990.

This Note comprises guidance in relation to new and existing processes and is based on an assessment of best available techniques as qualified by the requirement not to entail excessive cost. (Background guidance on the meaning of BATNEEC is contained in General Guidance Note 1².)

This Note also (where appropriate) gives information about any directions, limits, requirements, quality standards or quality objectives which were in force on the date of publication and which must be complied with in carrying on these processes, in accordance with section 7(2)(b) and (c) of the Act.

Section 7(1)(a) of the Act requires that the specific conditions set in an authorisation, together with the implied general condition in section 7(4), achieve all the objectives specified in section 7(2), including that in section 7(2)(a) given above.

In accordance with section 7(11), enforcing authorities are required to have regard to any guidance issued to them by the Secretary of State when determining appropriate techniques in relation to the above-mentioned objective. The Secretary of State will also treat this guidance as one of the material considerations when determining any appeals made against a local authority decision.

The guidance contained in this Note was determined after full consultation with the HM Inspectorate of Pollution/Local Authority Enforcement Liaison Committee (IPLA) and interested bodies. It is based on the state of knowledge and understanding of these processes, their potential impact on the environment, and the available control techniques at the time of publication. The guidance will be updated regularly to reflect changes in knowledge and understanding; however, it will not always be possible to revise the Notes quickly enough to keep in absolute step with rapid changes. Further, the guidance cannot take into account individual process characteristics, in particular location, which may on occasion influence the nature of the conditions that are included in an authorisation.

Guidance on interpretation of the terms used in the Note is provided in General Guidance Note 4 (GG4) *Secretary of State's Guidance on Interpretation of Terms used in Process Guidance Notes* (ISBN 0 11 753426 3, HMSO, price £1.90).

Processes must be operated in order to protect persons at work as well as the environment, therefore conditions in the authorisation must not impose any requirement that would put at risk the health, safety or welfare of persons at work. Section 7(1) of the Act requires that no conditions are to be imposed which are designed only to secure the health of persons at work (as defined in Part I of the Health and Safety at Work etc Act 1974).

Wherever emission limits quoted in this Note conflict with exposure limits set under the Health and Safety at Work etc Act 1974 to secure the health safety or welfare of persons at work, the tighter limits should prevail.

Introduction

- 1 Surfaced coatings are applied to leather in order to provide colour or lustre and to confer some protection from the effects of water and abrasion during wear or use. These surface coatings, or finishes, are characterised by their need to remain flexible, but non-tacky, over the temperature range encountered in use (-30°C to +100°C), or in the fabrication of leather products (up to 300°C). They will therefore consist of binders, pigments if appropriate, plasticisers, coalescing agents and other auxiliaries. There are three principal binder systems in use: resin emulsions manufactured by emulsion polymerisation, which contain low levels of organic solvent, generally under

²General Guidance Note 1 (GG1) *'Introduction to Part I of the Act'* (ISBN 0-11-752-123-9; price £5) includes general guidance on the interpretation of 'best available techniques not entailing excessive cost', the requirements of Articles 4, 12 and 13 of EC Directive 84/360/EEC, and the meaning of 'existing processes'.

- 3%; organic solvent thinnable lacquers which as applied will contain over 90% organic solvent; and lacquer emulsions, which are aqueous emulsions of binders, containing varying quantities of organic solvent as supplied, which will be diluted with water prior to application.
- 2 The coatings are typically applied to leather by means of padding, roller coaters and hand or machine spraying equipment. In order to develop the requisite combination of technical performance and aesthetic appeal multicoating, interspersed with ironing or embossing operations is common.
 - 3 These processes are prescribed for local authority air pollution control under Section 6.5 of Schedule 1 to the Environmental Protection (prescribed Processes and Substances) Regulations 1991, SI 472. Section 6.5 of Schedule 1 is reproduced in *Annex Ia* at the end of this Note.
 - 4 In the context of this Note, "process" comprises the whole process including the treating handling and storage of any materials used in end products and wastes produced by the process.
 - 5 This Note applies to all new processes, to replacement processes, to substantial changes to existing processes and the upgrading of existing processes to meet the standards of this Note.

Upgrading of Existing Processes

- 6 The first authorisation for an existing process will need to specify the interim conditions to be applied before the process is fully upgraded in accordance with this Note. Any authorisation issued during this initial period for an existing process should be on the basis that the BATNEEC objective for that process is secured by exercising the level of pollution control which is achievable (using plant and equipment existing at the process) at the time of authorisation, provided that the process is complying with what would have been the requirements (where appropriate) under the Clean Air Acts 1956 and 1968 (as amended) and the statutory nuisance provisions of Part III of the Environmental Protection Act (subject to considerations of best practicable means), and any interim standards included in this Note.
- 7 Where interim upgrading is necessary in order to achieve these levels of control, conditions specifying a timescale for completing the work should be drafted having regard to the requirement not to entail excessive cost (NEEC). It may, in some cases, be more cost effective for the operator to upgrade the process to the full standards required by the Note, rather than in stages.
- 8 As for control over nuisance, section 79 (10) of the Environmental Protection Act allows statutory nuisance action to be taken only in limited cases in relation to authorised processes - in particular, as regards noise nuisance. However, every Part I authorisation will implicitly impose on operators the general duty to use BATNEEC. The BATNEEC duty includes minimisation of offence to any of man's senses (although this does not cover noise because of the definition of "substance" in section 1(13) of the Act).
- 9 Existing processes² which do not already meet the standards of this Note should be upgraded to the standards of this Note whenever the opportunity arises. The timetable for upgrading should take into account the criteria included in Articles 4, 12 and 13 of

the European Communities Directive “On the Combating of Air Pollution from Industrial Plants” (84/360/EEC)². Only in exceptional circumstances should upgrading be completed later than 1 April 1996, with the exception of the requirements of Clause 20 which should be met by the dates indicated in the Clause.

- 10 Where necessary, a programme for upgrading should be submitted to the local authority within 6 months of the date of issue of the first authorisation.
- 11 The conditions contained in all authorisations should be reviewed by the local authority at intervals of not more than 4 years, in accordance with section 6(6) of the Act. Where complaint is attributable to operation of the process and is, in the opinion of the local authority, justified, or if new knowledge develops on the potential for harmful effects from emission, immediate review of the process should be undertaken. Any new requirements and compliance time-scales shall be specified by the local authority.

Emission Limits and Controls

- 12 All emissions to air, other than steam or water vapour, should be colourless and free from persistent mist. All emissions to air should be free from persistent fume and free from droplets.
- 13 The aim should be that all emissions are free from offensive odour outside the process boundary, as perceived by the local authority Inspector.
- 14 Emissions from combustion processes should in normal operation be free from visible smoke and in any case should not exceed the equivalent of Ringelmann Shade 1 as described in British Standard BS 2742:1969.
- 15 All pollutant concentrations should be expressed at reference conditions, 273K, 101.3 kPa, without correction for water vapour content.
- 16 The introduction of dilution air to achieve emission concentration limits should not be permitted. Exhaust flow rates should be consistent with efficient capture of emissions, good operating practice and meeting the requirements of the legislation relating to the workplace environment.
- 17 Where continuous monitoring is undertaken:
- no 24-hour mean of all 15-minute mean emission concentrations should exceed the specified emission concentration limits, and
 - no 15-minute mean emission concentration should exceed twice the specified emission concentration limits.

Compliance with this requirement should be demonstrated on a daily basis.

- 18 The specified emission concentration limits are:

| Emissions | Concentrations |
|--|-----------------------|
| Total particulate matter from automated spray machines | 50mg/m ³ |
| Volatile organic compounds from arrestment equipment installed to comply with Clause 21 (expressed as total carbon excluding particulate matter) | 50mg/m ³ |
| Carbon monoxide (from incinerators) | 100mg/m ³ |
| Nitrogen oxides measured as nitrogen dioxide (from | 100mg/m ³ |

incinerators)

- 19 The aim should be the reduction and eventual elimination of the use of organic solvents in surface coatings. Reduction in volatile organic compound emission could be achieved by the use of water based coatings (low organic solvent coating content) or the use of organic solvent-free coatings.
- 20 The mass emission of volatile organic compounds per square metre of leather coated, calculated in accordance with Clause 21, should not exceed:
- (a) 185g/m² for new processes,
 - (b) 185g/m² for existing processes from 1 April 1995, and
 - (c) 75g/m² for all processes from 1 April 1999.

Where it is necessary to install arrestment equipment to meet these limits, emissions from the arrestment equipment should meet the requirements of Clause 18.

- 21 The mass emission figure for volatile organic compounds should be calculated using the following information:
- (a) total quantity of leather coated (m²),
 - (b) coating material usage,
 - (c) organic solvent content of coatings,
 - (d) diluent organic solvent usage,
 - (e) total cleaning solvent usage,

– corrected for any emissions which are arrested. Compliance with the mass emission limit should be calculated on a monthly basis and forwarded to the local authority every 6 months. For the purpose of this Note organic solvents should be taken to be:

“organic materials which are liquid at 293K (20°C), which are volatilized during the coating and subsequent drying operations, and are used as a dissolver or viscosity modifier in the coating or as a cleaning agent”.

Monitoring, Sampling and Measurement of Emissions

- 22 As part of proper supervision the operator should monitor emissions and make tests and inspections of the process. The need for and scope of testing and the frequency and time of sampling, will depend on local circumstances, operational practice, and the scale of operation. The following should normally be included as standard requirements.
- 23 Where arrestment equipment is installed to meet the mass emission requirements of Clause 20, and when it is necessary to demonstrate compliance with Clause 18 for volatile organic compounds, emissions from coating application zones, dryers or their appropriate arrestment plant, should be continuously monitored from volatile organic compounds, for example, by the use of a flame ionisation instrument. (This does not apply in cases where Clause 24 below specifies that continuous monitoring for volatile organic compounds is not necessary.) The results should be continuously recorded.
- 24 Where the arrestment system includes a thermal incinerator and the incineration temperature and carbon monoxide emissions are continuously monitored it will not be necessary to monitor continuously for volatile organic compounds, but the requirements of Clause 25 below will apply.

- 25 Emissions from incinerators should be tested at least once a year for volatile organic compounds and nitrogen oxides.
- 26 Where the arrestment equipment includes thermal incineration, emissions should be continuously monitored for carbon monoxide and the results continuously recorded.
- 27 All continuous monitoring instruments should be checked daily and calibrated in accordance with the manufacturers' recommendations, and at least once a year.
- 28 Automated spray application unit emissions should be tested at least annually for total particulate matter. Where the emissions from spray units are vented to volatile organic compound arrestment equipment, the measurements should be taken on the exhaust air from that plant. This Clause does not apply to manual spray booths.
- 29 Visual and olfactory assessments of emissions should be made frequently and at least once a day. Remedial action should be taken immediately in the case of abnormal emissions.
- 30 A detailed inventory of organic solvent usage should be kept. This should include cleaning and diluent solvent usage and the solvent or volatile organic compound (as purchased) of coatings used. The inventory should be forwarded to the local authority at least every 6 months.
- 31 The results of all monitoring and inspections should be recorded in a log book, (including continuous monitor checks and records) retained by the operator for a minimum of 4 years and made available for examination by the local authority. Adverse results should be investigated immediately and in all cases should be recorded in the log book. The operator should ensure that the cause has been identified and corrective action taken, and this action recorded in the log book.
- 32 A summary of continuous emission monitoring results should be forwarded to the local authority at least once every 6 months. This information should include monthly averages, daily maximum 15-minute mean emission concentrations and the daily mean of all 15-minute mean emission concentrations.
- 33 In any case where the emission measurement exceeds the concentration limits specified in Clause 18 above, the results should be forwarded to the local authority. Where any emission concentration is more than twice the specified emission concentration limit, the local authority should be advised immediately.
- 34 The results of all non-continuous emission testing should be forwarded to the local authority within 8 weeks of the completion of the sampling.
- 35 Adequate, safe facilities for sampling should be provided on vents or ducts. Care is needed in the design and location of sampling systems in order to obtain representative samples.³
- 36 The reference test method for particulate matter emissions in chimneys or ducts is that of British Standard BS 3405:1983, and tests should be carried out according to the main procedural requirements of that standard.
For the measurement of the concentration of other pollutants, methods approved by the local authority should be used.

³ 'Sampling Facility Requirements for BCURA Testing' will be produced shortly by HMIP and published by HMSO.

Materials Handling and Storage

- 37 Adequate provisions should be made for the containment of liquid and solid spillages. All spillages should be cleared as soon as possible and in the case of solid material this should be achieved by the use of vacuum cleaning, wet methods, or other appropriate techniques. Dry sweeping of dusty spillages should not be permitted in circumstances where sweeping may lead to particulate matter emissions to the air.
- 38 In order to meet the requirements of Clause 13 of this Note, emissions from bulk storage vessels during offloading should either be vented to suitable arrestment plant (for example carbon adsorption cartridges) or backvented to the delivery tanker.
- 39 Bulk storage tanks should be fitted with a high level alarm or volume indicator to warn of overfilling, and this should be linked to an interlock to cause the interruption of filling operation when the alarm is activated.
- 40 Bulk chemical storage tanks should be completely contained by bunding which is impervious and resistant to the chemicals in storage and capable of holding 110% of the capacity of the largest storage tank.
- 41 All potentially odorous waste materials – for example, waste cleaning solvents and paint residue – should be stored in suitable enclosed containers or bulk storage vessels.
- 42 The cleaning of plant and equipment should be carried out in such a way that emissions of volatile organic compounds to air are prevented or controlled to meet the requirements of Clauses 13 and 18 above.
- 43 Hand spray guns should be cleaned in washers with an enclosed waste solvent collection container.
- 44 The transfer of coating from intermediate storage vessels to application equipment should be through closed delivery systems.
- 45 Storage areas for drums containing organic solvents should be provided with suitable containment kerbs, or floor gradients should be used to ensure containment of any spillage. All drums should be tightly lidded.
- 46 Emissions from mixing and coating storage vessels and tanks (excluding bulk storage tanks which are referred to in Clause 39 above) should be reduced by limiting agitation during mixing, by covering mixing vessels and avoiding the use of open containers to transfer solvents, and by reducing mixing times.

Processing

- 47 Emissions from dryers should be adequately contained, for example by the use of end zone exhaust ventilation or air curtains.
- 48 The temperature of all dryers should be continuously monitored and the reading observed on at least an hourly basis. The dryer temperature should be controlled to minimise the emission of high boiling point organic compounds from the coating formulation.
- 49 All dryers should be maintained under negative pressure, to prevent the leakage of gases from within the ductwork to the air.

- 50 Steps should be taken to increase the efficiency of transfer of coating materials and thereby reduce the emission of volatile organic compounds. This may be achieved, for example, by the use of electronic scanners at the entrance to the spraying machine which record the shape of hide being introduced to reduce over-spray; by the use of airless spray techniques to reduce coating deflection; by the use of roller coating techniques or other appropriate high transfer efficiency techniques.

Arrestment plant

- 51 Guidance on the measures necessary to control volatile organic compound arrestment equipment is included in Annex Ib of this Note.

Chimneys, Vents and Process Exhausts

- 52 The height of chimneys and vents from process and arrestment plant should be assessed on the basis of estimated ground level concentrations of the emitted residual pollutants. The chimney height so obtained should be adjusted to take into account local meteorological data, local topography, nearby emissions, and the influence of plant structure.⁴
- 53 The assessment should also take into account the relevant air quality standards and criteria that apply for the emitted pollutants.⁵
- 54 The minimum chimney or process vent height should be 3m above the roof ridge height of any building within a distance of 5 times the uncorrected chimney height and in no circumstances should be less than 8m above ground level.
- 55 Chimneys or process vents should be designed for an efflux velocity of not less than 15 m/sec in normal operation. Care should be taken to avoid generating positive pressure zones within the chimney unless the chimney wall is impervious or lined. Where a wet method or arrestment is used, the linear velocity within the chimney should not exceed 9 m/sec, to avoid entrainment of droplets from the chimney surface into the gas stream.
- 56 Chimneys or process vents should not be fitted with any restriction at the final opening, for example, a plate, cap or cowl, where it is necessary to achieve dispersion of the residual pollutants.
- 57 Chimney flues and ductwork leading to the chimney should be adequately insulated to minimise the cooling of waste gases and prevent liquid condensation on internal surfaces. Chimney flues and ductwork should be cleaned regularly to prevent accumulation of material.
- 58 Where the principal reason for a chimney or vent is to ensure odour dispersion, the discharge height can be estimated from the formula:

$$H_e = (0.1 DF)^{0.5}$$

where

⁴ Guidance for the determination of chimney heights is given in 'Chimney Heights: 3rd Edition of the 1956 Clean Air Act Memorandum' HMSO. ISBN 0-11-751556-6. An HMIP-approved guidance document on chimney height assessment will be published by HSMO as soon as possible.

⁵ The Air Quality Standards Regulations 1989 (SI 1989 No.317) specify current standards.

H_e is the effective chimney height in metres

D is the number of dilutions to detection threshold at the chimney exit, and

F is the volume flow at standard conditions (m^3s^{-1}).

General Operations

- 59** Effective control of emissions requires the maintenance and proper use of equipment, and the proper supervision of process operations. Effective preventive maintenance should be employed on all plant and the equipment concerned with the control of emissions to the air. Essential spares and consumables should be held.
- 60** Any malfunction or breakdown leading to abnormal emissions should be dealt with promptly and process operations adjusted until normal operations can be restored. All such malfunctions should be recorded in the log book. If there is likely to be an effect on the local community the local authority should be informed without delay. The local authority may need to identify key arrestment plant the failure of which should be notified to them immediately.
- 61** Staff at all levels should receive the necessary formal training and instruction in their duties relating to control of the process and emissions to air. Particular emphasis should be given to training for start-up, shut down and abnormal conditions.
- 62** A high standard of housekeeping should be maintained.

Annex Ia

Definition of Coating Processes in Schedule 1 of the Environmental Protection (Prescribed Processes and Substances) Regulations 1991, SI 472

(See Clause 3 of this Note)

6.5 Coating Processes

Part A

- (a) The application or removal of a coating material containing one or more tributyltin compounds or triphenyltin compounds, if carried out at a shipyard or boatyard at which vessels of a length of 25 metres or more can be built or maintained or repaired.
- (b) The treatment of textiles if the process may result in the release into water of any substance described in Schedule 5.
- (c) The application to a substrate of, or the drying or curing after such application of, printing ink or paint or any other coating as, or in the course of, a manufacturing process where the carrying on of the process by the person concerned at the location in question is likely to produce 1000 tonnes or more of special waste in any 12 months period.

Part B

- (a) Any process described in paragraph (c) of Part A (other than the respraying of vehicles) where:
 - (i) the process does not fall within that paragraph by reason of the qualification relating to special waste;
 - (ii) the process may result in the release into the air of particulate matter or of any volatile organic compound; and
 - (iii) the carrying on of the process by the person concerned at the location in question is likely to involve the use in any 12 month period of:
 - (aa) 20 tonnes or more of any printing ink, paint or other coating material which is applied in solid form; or
 - (bb) 20 tonnes or more of any metal coatings which are sprayed on in molten form; or
 - (cc) 5 tonnes or more of organic solvents.
- (b) Any process for the respraying of road vehicles not falling within paragraph (c) of Part A above if the process may result in the release into the air of particulate matter or of any volatile organic compound and the carrying on of the process by the person concerned at the location in question is likely to involve the use of 2 tonnes or more of organic solvents in any 12 month period.

In this Section:

“coating material” includes paint, varnish, lacquer, dye, any metal oxide coating, any adhesive coating, any elastomer coating and any metal or plastic coating; and in calculating for the purposes of Part B the amount of organic solvents used in a process, account shall be taken both of solvents contained in coatings and solvents used for cleaning or other purposes.

Annex Ib

Volatile Organic Compound Control Measures

- 1 This Appendix includes guidance on the volatile organic compound control measures which may be appropriate in relation to these processes. It is intended to provide guidance on standards relevant to the design and operation of control equipment. It is not intended as an exhaustive list of all available measures to control the emission of volatile organic compounds, but provides guidance on the more commonly encountered techniques.
- 2 The preferred method of control of volatile organic compounds is recovery, where practicable in relation to the type and mixture of solvents used in the process. However, if solvents are recovered for burning, the combustion plant should be specifically designed for the purpose and should be capable of meeting the emission standards for incinerators burning volatile organic compounds specified in Clause 18 above.

Arrestment plant: adsorption processes

- 3 There are a number of different adsorption media used in solvent recovery processes, the most common being carbon. Consideration should be given to their flammability risk where adsorption systems are proposed particularly where the solvents used include ketones.
- 4 During commissioning of adsorption plant, adsorption and desorption curves should be determined in order to establish the speed of solvent breakthrough. Emissions of volatile organic compounds from all adsorption beds should be continuously monitored and recorded, for example using an infrared gas analyser. The switch from adsorption to desorption cycle should be automated and triggered by measured solvent breakthrough in the adsorption phase. The volatile organic compound concentration in exhaust air at which desorption occurs should be established from the breakthrough curve obtained during commissioning testing and should meet the emission requirements and standards as appropriate.
- 5 The concentration of volatile organic compounds in waste gases before and after the adsorption efficiency of the plant. This efficiency measure will also identify any potential adsorption medium deterioration.
- 6 In addition the adsorption/desorption cycle periods should be recorded on a weekly basis to indicate potential adsorption medium deterioration.
- 7 The exhaust air from the adsorber during the period of solvent laden steam venting from the bed following steam desorption should be vented to a condenser to remove solvent laden steam and should be discharged from the condenser back to an adsorber inlet to meet the emission standards and requirements. This is commonly termed "plume control".

- 8 During desorption all exhaust air should be vented to an adsorber inlet following solvent recovery by a condenser. All recovered solvent should be discharged to storage vessels using a closed loop pipeline. All such storage vessels should be vented to suitable arrestment plant where necessary to meet the emission requirements and standards.
- 9 Following the plume control period, it is necessary to recondition the adsorber bed prior to recommencement of the adsorption cycle; this reconditioning will remove the moisture from the bed and dry the bed. During this period (commonly 10-15 minutes) only uncontaminated air should be passed to the adsorber and this can be discharged to air from the adsorber exhaust. Emissions during this period should be discounted when calculating the time-weighted average volatile organic compound emission. If solvent laden air is fed into the adsorber during this period, the exhaust from the adsorber should be vented directly to another adsorber inlet unless the direct exhaust emission from the bed undergoing reconditioning meets the emission requirements and standards.
- 10 The flow of cooling water to condensers, and where appropriate distillation equipment, should be continuously monitored, for example using a variable orifice meter. The monitor should be fitted with an audible and visual alarm to indicate flow failure.

Arrestment plant: condensation

- 11 There are a number of methods of using condensation techniques to recover solvent and control volatile organic compound emissions. One applicable technique is cryogenic condensation for the recovery of solvent from an inert atmosphere (commonly a nitrogen atmosphere). In these circumstances a reduced gas flow to the oven is utilised with complete or partial recirculation of exhaust gases, therefore compliance with the emission concentration limit is not generally appropriate. In these circumstances volatile organic compound concentrations in the drying ovens should be continuously monitored and recorded and recovered solvent quantities should be recorded to demonstrate the solvent recovery efficiency of the system. The target efficiency should be 96% recovery when the arrestment plant is operating at maximum design solvent input. Recovery efficiency should not be less than 90% when operating below maximum design solvent input.

Arrestment plant: incinerators

- 12 Although the emission concentration limit for volatile organic compounds is 50mg/m^3 , there may be some circumstances in which, using the BATNEEC concept, it will be difficult to maintain compliance with this standard – for example, where the input solvent concentration to the incinerator is extremely high (typically above 15g/m^3). In these circumstances it may be necessary to assess what emission standard is achievable in accordance with BATNEEC and to specify a limit which can be achieved using the quoted arrestment efficiency of the proposed incinerator.
- 13 There are a number of different types of incinerator which are capable of achieving these limits, including recuperative thermal incinerators, regenerative thermal incinerators, catalytic incinerators and “sand box” incinerators. Where incineration is installed for new or replacement processes, primary or secondary heat recovery should be incorporated into the design of the process. Where practicable in relation to the

process characteristics and heat requirements, heat recovery should be included on incineration provided at existing processes.

- 14** Where arrestment plant includes thermal incinerators, they should be operated at a temperature consistent with achieving the emission requirements for volatile organic compounds, carbon monoxide and nitrogen oxides and the concentrations specified in Clause 19 of this Note. The temperature of gases in the combustion zone should be continuously monitored and continuously recorded. During the commissioning of new plant, incinerator temperature and emission concentration profiles of volatile organic compounds, carbon monoxide and nitrogen oxides should be established to demonstrate the operating conditions necessary to ensure destruction of volatile organic compounds to the required standard. Continuous monitoring for temperature and carbon monoxide emissions will be sufficient to demonstrate compliance with commissioning profiles for adequate volatile organic compound destruction.

Arrestment plant: absorption processes

- 15** In some cases where water miscible solvents are used it may be possible to reduce emissions to the specified standards by wet scrubbing. In addition, for more complex operations, absorption systems are available using selective solvents to absorb the volatile organic compounds under consideration. In these circumstances, liquor circulation should be continuously monitored and continuously recorded – for example, by use of a variable orifice meter. It may also be necessary to measure chemical parameters of the circulating liquor – for example, where selective solvent absorption is used the concentration of absorption solvent in the liquor should be monitored.

General

- 16** It is intended to publish additional information concerning currently available technology for the reduction of volatile organic compound emissions.
- 17** The use of odour-masking agents or counteractants should not be permitted.

© Crown Copyright 1992

Applications for reproduction should be made to HMSO

First Published 1992

ISBN 0 11 752603 7

HMSO publications are available from:

HMSO Publications Centre

(Mail, fax and telephone orders only)

PO BOX 276, London SW8 5DT

Telephone orders 0171 873 9090

General enquiries 0171 873 0011

(queuing system in operation for both numbers)

Fax orders 0171 873 8200

HMSO Bookshops

49 High Holborn, London WC1V 6HB 0171 873 0011 (Counter service only)

258 Broad Street, Birmingham B1 2HE 0121 643 3740

Southey House, 33 Wine Street, Bristol BS1 2BQ 01272 264 306

9-21 Princess Street, Manchester M60 8AS 0161 834 7201

80 Chichester Street, Belfast BT1 4JY 01232 238 451

71 Lothian Road, Edinburgh EH3 9AZ 0131 228 4181

HMSO's Accredited Agents

(see Yellow Pages)

and through good booksellers

Annex II

Examples of Health and Safety Data Sheets for Chemicals

Material Safety Data Sheet

Earnshaw Limited, Darlington Rd, Northallerton, North Yorkshire DL6 2PQ Tel: 01609 776456 Fax: 01609 780203

IDENTIFICATION: ENKRALAC CLEAR
C.A.S. No: Mixture

Product Composition

| Description: Nitrocellulose lacquer in solvents | | |
|---|--------|--------------|
| Component | Symbol | Risk Phrases |
| Methoxypropanol | | 10 |
| Methoxypropyl acetate | | 10 |
| Hydrocarbon solvent | | 10 |

Hazard Identification

Classification: Flammable.

Risk: Inhalation of vapour may produce headache, dizziness, unconsciousness. Methoxypropanol can be absorbed through intact skin with possible harmful effects.

Warning: This product contains nitrocellulose and a build-up of the solid in the ducting of spray equipment is extremely hazardous.

First Aid Measures

Eye Contact: Rinse immediately with water for at least 10 minutes.

Skin Contact: Remove contaminated clothing. Wash skin with soap & water.

Ingestion: Wash out mouth with water. Drink plenty of water.

Inhalation: Remove to fresh air. Seek medical aid if exposure is prolonged.

Fire Fighting Measures

Suitable Extinguishers: Chemical foam, powder, carbon dioxide.

Restrictions: Waterspray.

Fire/explosion Hazard: Flammable vapour/air mixture

Special Equipment: Self-contained breathing apparatus.

Accidental Release

Safety Precautions: Ensure adequate ventilation. Extinguish sources of ignition.

Environmental Precautions: Do not allow to enter drains

Clean-up Procedure: Cover with absorbent material & place in containers for disposal.

Handling and Storage

Storage: Keep containers closed. Store in a cool dry area away from sources of ignition, with adequate ventilation in accordance with Highly Flammable Liquid and LPG Regulations.

Handling: Avoid inhalation, ingestion & contact with skin/eyes.

Version No 1 (August 1994)

MSDS Code No: L479

Exposure Controls / Personal Protection

Components with occupational exposure limits:
 Methoxypropanol (skin)

Personal Protection: Adequate ventilation, goggles, gloves.

Physical and Chemical Properties

Form: Colourless liquid

Boiling point: °C

Flash point: 36°C

Explosive Limits:

Vapour Pressure:

Solubility in water 20°C:

Evaporation Rate (nBac = 100):

Stability and Reactivity

Stable under normal storage conditions.

Toxicological Information

Acute oral toxicity:

Eyes:

Inhalation: not available

Skin: not available

Ingestion: not available

Ecological Information

Toxicity Fish:

Plants:

Comments: Do not allow to enter open water.

Disposal Considerations

Waste products may be disposed of by controlled incineration. National & local legislation concerning the disposal of waste must be complied with.

Transport Information

UN Number: 2059

EEC No:

Additional Data:

Regulatory Information (supply)

Symbol & Classification: Flammable

R-Phrases: 10

S-Phrases: 23, 38

Other information:

nc = not classified

Material Safety Data Sheet

Eamshaw Limited, Darlington Rd, Northallerton, North Yorkshire DL6 2PQ Tel: 01609 776456 Fax: 01609 780203

IDENTIFICATION: Polyurethane Lacquer M
C.A.S. No: Mixture

Product Composition

Description: Lacquer in solvent solution

| Component | Symbol | Risk Phrases |
|-----------------------|--------|--------------|
| Methoxypropanol | | 10 |
| Methoxypropyl acetate | | 10 |
| Hydrocarbon solvent | | 10 |

Hazard Identification

Classification: Flammable.

Risk: Inhalation of vapour may produce headache, dizziness, unconsciousness. Methoxypropanol can be absorbed through intact skin with possible harmful effects.

Warning: This product contains nitrocellulose and a build-up of the solid in the ducting of spray equipment is extremely hazardous.

First Aid Measures

Eye Contact: Rinse immediately with water for at least 10 minutes.

Skin Contact: Remove contaminated clothing. Wash skin with soap & water.

Ingestion: Wash out mouth with water. Drink plenty of water.

Inhalation: Remove to fresh air. Seek medical aid if exposure is prolonged.

Fire Fighting Measures

Suitable Extinguishers: Chemical foam, powder, carbon dioxide. **Restrictions:** Waterspray.

Fire/explosion Hazard: Flammable vapour/air mixture. Toxic gases may be evolved on combustion.

Special Equipment: Self-contained breathing apparatus.

Accidental Release

Safety Precautions: Ensure adequate ventilation. Extinguish sources of ignition.

Environmental Precautions: Do not allow to enter drains

Clean-up Procedure: Cover with absorbent material & place in containers for disposal.

Handling and Storage

Storage: Keep containers closed. Store in a cool dry area away from sources of ignition, with adequate ventilation in accordance with Highly Flammable Liquid and LPG Regulations.

Handling: Avoid inhalation, ingestion & contact with skin/eyes.

Version No 1 (August 1994)

MSDS Code No: L492

Exposure Controls / Personal Protection

Components with occupational exposure limits: Methoxypropanol (skin)

Personal Protection: Adequate ventilation, goggles, gloves.

Physical and Chemical Properties

Form: Colourless liquid

Boiling point: °C

Flash point: 36°C

Explosive Limits:

Vapour Pressure:

Solubility in water 20°C:

Evaporation Rate (nBac = 100):

Stability and Reactivity

Stable under normal storage conditions.

Toxicological Information

Acute oral toxicity:

Eyes:

Inhalation: not available

Skin: not available

Ingestion: not available

Ecological Information

Toxicity Fish:

Plants:

Comments: Do not allow to enter open water.

Disposal Considerations

Waste products may be disposed of by controlled incineration. National & local legislation concerning the disposal of waste must be complied with.

Transport Information

UN Number: 2059

EEC No:

Additional Data:

Regulatory Information (supply)

Symbol & Classification: Flammable

R-Phrases: 10

S-Phrases: 23, 38

Other information:

nc = not classified

Product Safety Data Sheet

BASF United Kingdom Limited

BASF AG ref: SD 0963 Date: 01.80
Translation ref: HH/173 Date 10.85

Product Name: © Corial EM Finish F
Chemical Nature: Cellulose nitrate emulsion in aqueous organic medium

1. Physical Data

- 1.1 **Melting / softening point:** °C
- 1.2 **Boiling point:** 100 - 194 °C
- 1.3 **Decomposition temperature:** n.a.
- 1.4 **pH:** 4-7 (at 660g/l water)
- 1.5 **Solubility in water:** 20°C miscible
- 1.6 **Characteristic odour:** Yes
- 1.7 **Physical form:** Liquid
- 1.8 **Vapour pressure (20°C):** m/bar
- 1.9 **Density (20°C):** 1.02 g/cm³

2. Storage Stability and Handling

- 2.1 **Special precautions on transport and storage:**
Containers must be kept tightly closed. Protect from heat. Protect from freezing.
- 2.2 **Incompatible substances:** None
- 2.3 **Hazardous decomposition products:** None
- 2.4 **Hazardous reactions:** None
- 2.4.1 **Preventative measures:** None
- 2.5 **Protective precautions:** Eye protection
- 2.6 **Special precautions:** Ensure good ventilation of work places.
- 2.7 **Procedure on spillage and leakage:** Soak up with absorbent material (e.g. sand, kieselguhr).
- 2.8 **Disposal:** With due regard to local regulations the product can be disposed of in special waste disposal plants, e.g. authorised incinerators.

3. Ignition and Combustion data

- 3.1 **Flash point:** 62 °C; **Method:** DIN 51 758
- 3.2 **Ignition temperature:** °C; **Method:**
- 3.3 **Extinguishing media:** Water spray, CO₂, foam, dry powder
- 3.4 **Special fire precautions:** None
- 3.5 **Special fire and explosion hazards:** None.

4. Toxicity

- 4.1 **Acute oral toxicity (LD₅₀):** 3,500 mg/kg tested on rats
- 4.2 **Skin irritation:** Slightly irritant, tested on rabbits.
- 4.3 **Eye irritation:** Moderately irritant, tested on rabbits eyes.

5. Emergency First Aid Precautions

Remove contaminated clothing immediately. Wash affected skin thoroughly with plenty of water. Wash affected eyes thoroughly with running water for at least 10 minutes with eyelids held open. If irritation persists consult an eye specialist. If taken internally or if distress is felt after inhalation of vapours / aerosol, remove affected person to fresh air, keep quiet and summon medical aid.

6. Ecology

- 6.1 Product should not be disposed of into rivers or other waters without pretreatment. Provided product is correctly processed, effluent will not be polluted.
- 6.2 **Fish toxicity LC₅₀ mg/l**
Test species LC₅₀ mg/l, testing time h

7. Additional Information

The normal precautions for the handling of chemicals must be observed.
Avoid inhalation of vapours.

Glossary of Terms and Abbreviations used in BASF Safety Data Sheets

1. Authorities and Bodies

DIN: Deutsches Institut fuer Normung
(German Standards Organisation)
EEC: European Economic Community.
ETAD: Ecological & Toxicological Association of the
Dyestuffs Manufacturing Industry.
HSE: Health & Safety Executive.
ISO: International Organisation for Standardisation
NIOSH: National Institute for Occupational
Safety & Health (USA).
OSHA: Occupational Safety and Health Administration (USA).
DOT: Department of Transportation (USA).
OECD: Organisation for Economic Cooperation & Development.

2. Ecology and Disposal

2. Ecology & Disposal
COD: Chemical Oxygen Demand
BSB: (German for above)
BOD: Biochemical Oxygen Demand
CSB: (German for above)
DOC: Dissolved Organic Carbon
TOC: Total Organic Carbon
OECD: (See Sec 1) Reference to test methods
CO₂: Carbon Dioxide Production
WGK: 0-3: West German Classification of Hazard to Water,
based on acute toxicity to mammals, fish and bacteria,
and biological eliminability.
0 = no hazard, 1 = slight hazard, 2 = hazardous, 3 = severe hazard

3. Inventories and Lists

AICS: Australian Inventory of Chemical Substances
EINECS: European Inventory of Existing Chemical Substances
MITI (LIST): Japanese Inventory of Chemical Substances
TSCA (LIST): American register of chemicals
according to Toxic Substances Control Act

4. Regulations – Use, Supply and Storage

Arbeitsstoff Verordnung or Gefahrstoff Verordnung:
West German laws similar to the UK CPL Regulations,
all based on EEC Directives.
CPL: The Classification, Packaging & Labelling of Dangerous
Substances Regulations 1984 SI No. 1244 & amendments.
COSHH: The Control of Substances Hazardous to Health
Regulations 1988 SI No. 1657
FEPA: The Food and Environmental Protection Act 1985
VbF: German equivalent of UK Storage of Highly
Flammable Liquids Regulations 1972 SI No. 917.

5. Regulations – Transport

ADR: International Carriage of Dangerous Goods by Road
RID: International Carriage of Dangerous Goods by Rail
IMDG: International of Maritime Dangerous Goods Code
MFAG: Medical First Aid Guide (For use on ships)
EMS: Emergency Procedures for Ships carrying
Dangerous Goods
IATA: Dangerous Goods Regulations by Air
ICAO: Technical Instructions for Safe Transport
of Dangerous Goods
UN No: United Nations Number
SIN: Substance Identification Number (Same as UN No.)
CI No: Colour Index Number
CAS No: Chemical Abstracts Services Registry Number (USA)

6. Toxicity

LD₅₀, LC5₀: Result of acute toxicity tests
MAK Value: West German list of maximum
airborne contaminants
TRK: West German Technical Threshold Values
ACGIH: American Conference of Governmental
Industrial Hygienists (who publish TLVs)
TLV: Threshold Limit Value (similar to MAK)
OEL: Occupational Exposure Limit –
Listed in HSE Guidance Note EH40
MEL: Maximum Exposure Limit: – (in COSHH Regs)
to replace OEL Control limit
OES: Occupational Exposure Standard (in COSHH Regs)
to replace OEL Recommended Limit
RTECS: Register of Toxic Effects of Chemical Substances (USA)

This product should be stored, handled and used in accordance with good industrial hygiene practices and in conformity with any legal regulation. The information contained herein is based on the present state of our knowledge and is intended to describe our products from the point of view of safety requirements. It should not therefore be construed as guaranteeing specific properties.

BASF United Kingdom Limited

P.O. Box 4
Earl Road
Cheadle Hume
Cheadle
Cheshire
SK8 6QG

Tel: 0161 485 6222 (24 hours)
Telex: 669211 BASFCH G Fax: 0161 486 0891

Product: LS8433
Description: Lacquer emulsion
Date: 12-12-89

010 Physical Data

| | |
|--------------------------------|------------------------|
| Solids (%): | 14 - 16 |
| Viscosity (20°C): | 400 - 800 |
| Boiling point (°C) | 100 - 180 |
| Flash point (°C) | 44 |
| pH | - |
| Solubility | Dispersable |
| Odour | Organic solvent odour |
| Appearance | Whitish liquid |
| Vapour pressure | Approx 2.3 mbar (DIBK) |
| Explosive limits (Vol%) | 0.8 - 6.2 |
| Specific gravity | 0.880 |

020 Substances Hazardous to Health

| Substance | % Range | O.E.L. |
|---------------------------|-------------|----------|
| Diisobutyl Ketone | 40 - 50 | 25 ppm |
| Iso Butanol | less than 5 | 50 ppm |
| C8/9 Aromatic Hydrocarbon | 10 - 20 | 25 ppm |
| 2-Butoxy-ethanol | 5 - 10 | 25 ppm * |

* control limits

All these substances are irritating to the eyes, skin & respiratory system.

030 Storage and Handling

- 031 Storage:** Store in a cool well ventilated place away from sources of ignition and heat. Keep containers closed.
- 032 Protection requirements:** Wear solvent resistant gloves and eye protection.
- 033 Special precautions:** Use with adequate ventilation. Avoid breathing vapours, skin & specified protection & a respirator if extraction is inadequate. Take precautions against static discharges.
- 034 Spill or leak procedure:** Wear suitable protective clothing & a respirator if necessary. Isolate / remove sources of ignition. Absorb with sand or any inert absorbent & transfer to sealed containers for disposal. Small spillages may be wiped up & flushed with water.
- 035 Method of disposal:** Burn under controlled conditions or bury in accordance with local authority regulations. Employing the services of a reputable waste disposal contractor is recommended.
- 036 Environmental hazards:** Do not discharge into or allow spillages to enter drains sewers or waterways. This could lead to a potential fire/explosion hazard at a distant location. The product may also be toxic to fish and micro organisms used for water treatment.
- 037 Incompatible substances:** Strong acids, alkalis & oxidizing agents.

Please study this material safety data sheet carefully to familiarise yourselves with any hazards and safe handling procedures associated with the product.

We also ask you to pass this information onto any of your employees, customers, clients and contractors that may become involved in handling the product.

040 Fire Hazard Data

- 041 Extinguishing media:** Extinguish with alcohol resistant foam, fine water spray or halon. Small fires may be extinguished with carbon dioxide or chemical powder.
- 042 Special fire precautions:** Wear self-contained breathing apparatus & protective clothing. Keep exposed containers cool with water spray. Do not use a water jet to extinguish a fire.
- 043 Unusual fire/explosion hazards:** Flammable liquid, may float on water presenting a floating fire hazard. Vapours can form explosive mixtures with air above the flash point.

050 Health Hazard Data

- 051 Effects of short term over exposure:**
- Ingestion:* not considered normal route of entry
- Skin contact:* redness, degreasing, redness & degreasing may be absorbed
- Eye contact:* redness and pain
- Inhalation:* headache dizziness
nausea sore throat
coughing shortness of breath
laboured breathing
- 052 Effects of long term overexposure:**
- May lead to:* dermatitis
may affect the nervous system
blood disorders
kidney injury

060 Emergency and First Aid Procedures

- 061 Inhalation:** Remove affected person to fresh air. Give artificial respiration if breathing has stopped. Oxygen may be given if breathing is difficult. Seek medical attention.
- 062 Skin contact:** Remove any contaminated clothing & wash skin thoroughly with soap and water. Seek medical advice if necessary.
- 063 Eye contact:** Rinse immediately with plenty of water & continue rinsing for at least 15 minutes. Seek medical attention if necessary.
- 064 Ingestion:** Rinse mouth, & give approximately 1 pint of water or milk to drink. Do not induce vomiting, seek immediate medical attention.

DIN Safety Data Sheet

SANDOZ QUINN-Produkte GmbH, Maybachstr. 18, D-7022 Leinfelden-E.1, Tel: 0711/7 59 05-0, Telex 7 255 510

Commercial Product Name: Aqualen Top 2001

- 1.1 **Chemical characterization:** Aqueous dispersion of a acrylate-copolymer
 1.2 **Form:** liquid
 1.3 **Colour:** milky-white
 1.4 **Odour:** product specific

2 Physical data and safety data

- 2.1 **Change in physical state:** Initial boiling point from 100°C
 2.2 **Density:** (20°C) 1.03 g/cm³
 Bulk density n.a.
 2.3 **Vapour pressure:** (20°C) 23 mbar (water)
 2.4 **Viscosity:** (20°C) 1500-3000 mPas
 2.5 **Solubility in water:** (20°C) miscible
 2.6 **pH value:** 7 - 8,5
 2.7 **Flash point:** none
 2.8 **Ignition temperature:** n.d.
 2.9 **Explosion limits:** Lower: n.d. Upper: n.d.
 2.10 **Thermal decomposition:**) if stored and handled
 2.11 **Hazardous decomposition products:**) according
 2.12 **Hazardous reactions:**) to instructions:
 2.13 **Further information:** none

3 Transport

GGVSee/IMDG code: - UN No.: -
 ICAO/IATA-DGR: - GGVE/GGVS: -
 RID/ADR: - ADNR: -
Other information: No hazardous good according to the present valid transport instructions.

4 Regulations

To our knowledge this is no hazardous product respectively no hazardous preparation according to Enclosure I, No. 1.1 of the instructions for dangerous goods resp. EC-Guideline for classification and labelling.

5 Protective measures, storage and handling

- 5.1 **Technical protective measures:** Keep container tightly closed. Store product protected from heat and freezing. Take care of good aeration.

5.2 Personal protective equipment:

Respiratory protection: Eye protection: x
Hand protection: x Other:

5.3 **Industrial hygiene:** Observe the usual precautions for the handling of chemicals.

5.4 **Protection against fire and explosion:** none

5.5 **Disposal:** Incinerate, suitable desposit, observe local regulations.

6 Measurements in case of accidents and fires

6.1 **After spillage/leakage/gas leakage:** Take up product with absorbent material and remove according to instructions.

6.2 Extinguishing media:

Suitable: water mist, foam, dry powder, CO₂
Not to be used: -

6.3 First aid:

Skin: wash with plenty of water and skin-protecting media.
Eyes: rinse under running water, if necessary see oculist.

6.4 Further information:

7 Information on toxicity

(components)

LD₅₀ (rat, oral) > 2000 mg/kg

8 Information on ecological effects

Avoid entry into sewage system and waters.

Water endangering class: 2 slightly endangering to water (self classification)

9 Further information

Due to the composition irritation of skin and eyes is possible.

DIN 52 900 09/90

The information contained herein is based on the present state of our knowledge. This product should be stored, handled and used in accordance with good industrial hygiene practices and in conformity with any legal regulations.

n.d. = no data n.a. = non applicable

DIN Safety Data Sheet

SANDOZ QUINN-Produkte GmbH, Maybachstr. 18, D-7022 Leinfelden-E.1, Tel: 0711/7 59 05-0, Telex 7 255 510

Commercial Product Name: Aqualen Top 2002

- 1.1 **Chemical characterization:** Aqueous dispersion of a aliphatic polyurethane
 1.2 **Form:** liquid
 1.3 **Colour:** milky-white
 1.4 **Odour:** product specific

2 Physical data and safety data

- 2.1 **Change in physical state:** Initial boiling point from 100°C
 2.2 **Density:** 1.03 g/cm³
 Bulk density n.a.
 2.3 **Vapour pressure:** (20°C) 23 mbar (water)
 2.4 **Viscosity:** (20°C) 1500-3000 mPas
 2.5 **Solubility in water:** miscible
 2.6 **pH value:** 7 - 9
 2.7 **Flash point:** none
 2.8 **Ignition temperature:** n.d.
 2.9 **Explosion limits:** Lower: - Upper: -
 2.10 **Thermal decomposition:**) if stored and handled
 2.11 **Hazardous decomposition products:**) according to
 2.12 **Hazardous reactions:**) instructions: none
 2.13 **Further information:**

3 Transport

GGVSee/IMDG code: - UN No.: -
 ICAO/IATA-DGR: - GGVE/GGVS: -
 RID/ADR: - ADNR: -
Other information: No hazardous good according to the present valid transport instructions.

4 Regulations

To our knowledge this is no hazardous product respectively no hazardous preparation according to Enclosure I, No. 1.1 of the instructions for dangerous goods resp. EC-Guideline for classifications and labelling.

5 Protective measures, storage and handling

- 5.1 **Technical protective measures:** Keep container tightly closed. Store product protected from heat and freezing. Take care of good aeration.

5.2 Personal protective equipment:

Respiratory protection: Eye protection: x
 Hand protection: x Other:

5.3 **Industrial hygiene:** Observe the usual precautions for the handling of chemicals.

5.4 **Protection against fire and explosion:** none

5.5 **Disposal:** Incinerate, suitable desposit, observe local regulations.

6 Measurements in case of accidents and fires

6.1 **After spillage/leakage/gas leakage:** Take up product with absorbent material and remove according to instructions.

6.2 Extinguishing media:

Suitable: water mist, foam, dry powder, CO₂
Not to be used: -

6.3 First aid:

Skin: wash with plenty of water and skin-protecting media.
Eyes: rinse under running water, if necessary see oculist.

6.4 Further information:

7 Information on toxicity (of a similar product)

(components)

LD₅₀ (rat, oral) > 5000 mg/kg
 Irritation of eyes and skin possible.

8 Information on ecological effects

Avoid entry into sewage system and waters.

Water endangering class: 1 slightly endangering to water (self classification)

9 Further information

DIN 52 900 09/90

The information contained herein is based on the present state of our knowledge. This product should be stored, handled and used in accordance with good industrial hygiene practices and in conformity with any legal regulations.

n.d. = no data

n.a. = non applicable

Product Safety Data Sheet

BASF plc

BASF AG ref: EP04435
Valid Date: 8/90
Replaces issue of:

BASF UK ref: EP04435
Translation ref: HH/5558

Product Name: © Astacin Hardener IC

- 1.1 **Chemical nature:** Polyfunctional isocyanurate based on hexamethylenediisocyanate, in organic solvent
1.2 **Form:** Liquid
1.3 **Colour:** None to pale yellowish
1.4 **Odour:** Specific

2 Physical data and safety data

- 2.1 **Change in physical state:**
2.2 **Density:** (20°C) 1.10 g/cm³
Bulk density.
2.3 **Vapour pressure:** mbar
2.4 **Viscosity:** (23°C) 13 sec. DIN 53211
2.5 **Solubility in water:** emulsifiable
2.6 **pH:**
2.7 **Flash point:** ca. 49°C DIN 55679
2.8 **Ignition temperature:**
2.9 **Explosion limits:** Lower. Upper.
2.10 **Thermal decomposition:**
2.11 **Hazardous decomposition products:** Isocyanates can form if the product smoulders.
2.12 **Hazardous reactions:** Pressure builds up in sealed containers if moisture enters. CO₂ forms. Danger of container bursting.

3 Transport

IMDG code: 3.3 UN-Nr: 1993
ICAO/IATA-DGR: 1993 RID/ADR: 3,31c
Other information: Flammable substance, contains 1-methoxy-2-propylacetate.
MFAG 4.4 EMS 3-07 Packaging Gp. III

4 Regulations

- 4.1 **Information on labelling:** In accordance with information supplied by our parent company, this product is classified according to EEC Directives and the UK CPL Regulations SI 1984 No. 1244 and amendments.
Risk phrase: 10 = Flammable
Safety phrases: 23 - 24/25 = Do not breathe product vapour/aerosol. Toxic in contact with skin and if swallowed.
4.2 **Other information:** The product contains 1-methoxy-2-propylacetate and as residual monomer, hexamethylenediisocyanate, the German "MAK" values for which should be noted. In the UK the equivalent is HSE Guidance Note EH40 on OELs and the current edition should be consulted for any MEL/OES values.
VbF = All (German flammable liquid rating).
Contains isocyanates.
WGK 1 = slight hazard. Own rating. See glossary.

5 Protective measures, storage and handling

- 5.1 **Technical protective measures:** Ensure thorough ventilation of work areas. Protect against moisture. Air extract must be fitted if product is applied by spraygun.
5.2 **Personal Protective Equipment:**
Respiratory: Breathing apparatus must be worn if product is applied by spraygun.
Eye: Goggles. *Hand:* PVC gloves
Other: Do not inhale product vapour.
5.3 **Industrial hygiene:** The normal precautions for the handling of chemicals must be observed.
5.4 **Protection against fire and explosion:**
As for flammable liquids.
5.5 **Disposal:** Can be disposed of in special waste disposal plants, eg. suitable incinerators, in accordance with local regulations. *NB. Empty but uncleaned receptacles are still hazardous if they have contained dangerous substances, and should be disposed of in accordance with current legislation.*

6 Measurements in case of accidents and fires

- 6.1 **After spillage/leakage/gas leakage:** Soak up with absorbent material and dispose of in accordance with Para. 5.5.
6.2 **Extinguishing media:**
Suitable:
 water jet foam CO₂ dry powder
 water spray/fog other:
6.3 **First aid:** Remove contaminated clothing. Wash affected skin with soap and water. Wash affected eyes under running water for at least 15 minutes with eyelids held open; consult an eye specialist. If affected persons complain of feeling unwell after inhaling product vapour/aerosol, and after product is swallowed, remove them to fresh air and summon medical aid.

7 Information on toxicity

Acute oral toxicity (rats): LD₅₀ > 5000 mg/kg
Skin irritation (rabbits): Non-irritant. OECD test 404.
Eye irritation (rabbits): Non-irritant. OECD test 405.

8 Ecology (more highly concentrated product)

Elimination from water: 20 - 70%, DOC, OECD Test 302B, i.e. moderate.
Bacterial toxicity: > 160 mg/l, ISO Test 8192B

9.1 Further information

Persons suffering from respiratory conditions, e.g. asthma, bronchitis etc, should not handle this product.

Format based on DIN 52 900

Glossary of Terms and Abbreviations used in BASF Safety Data Sheets

1. Authorities and Bodies

DIN: Deutsches Institut fuer Normung
(German Standards Organisation)
EEC: European Economic Community.
ETAD: Ecological & Toxicological Association of
the Dyestuffs Manufacturing Industry.
HSE: Health & Safety Executive.
ISO: International Organisation for Standardisation
NIOSH: National Institute for Occupational Safety & Health (USA)
OSHA: Occupational Safety and Health Administration (USA).
DOT: Department of Transportation (USA).
OECD: Organisation for Economic Cooperation & Development.

2. Ecology and Disposal

COD: Chemical Oxygen Demand
BSB: (German for above)
BOD: Biochemical Oxygen Demand
CSB: (German for above)
DOC: Dissolved Organic Carbon
TOC: Total Organic Carbon
OECD: (See Sec 1) Reference to test methods
CO₂: Carbon Dioxide Production
WGK: 0-3: West German Classification of Hazard to Water,
based on acute toxicity to mammals, fish and bacteria,
and biological eliminability.
0 = no hazard, 1 = slight hazard, 2 = hazardous, 3 = severe hazard

3. Inventories and Lists

AICS: Australian Inventory of Chemical Substances
EINECS: European Inventory of Existing Chemical Substances
MITI (LIST): Japanese Inventory of Chemical Substances
TSCA (LIST): American register of chemicals according
to Toxic Substances Control Act

4. Regulations – Use, Supply and Storage

Arbeitsstoff Verordnung or Gefahrstoff Verordnung:
West German laws similar to the UK CPL Regulations,
all based on EEC Directives.
CPL: The Classification, Packaging & Labelling of Dangerous
Substances Regulations 1984 SI No. 1244 & ammendments.
COSHH: The Control of Substances Hazardous to
Health Regulations 1988 SI No. 1657
FEPA: The Food and Environmental Protection Act 1985
VbF: German equivalent of UK Storage of Highly
Flammable Liquids Regulations 1972 SI No. 917.

5. Regulations – Transport

ADR: International Carriage of Dangerous Goods by Road
RID: International Carriage of Dangerous Goods by Rail
IMDG: International of Maritime Dangerous Goods Code
MFAG: Medical First Aid Guide (For use on ships)
EMS: Emergency Procedures for Ships carrying
Dangerous Goods
IATA: Dangerous Goods Regulations by Air
ICAO: Technical Instructions for Safe Transport of
Dangerous Goods
UN No: United Nations Number
SIN: Substance Identification Number (Same as UN No.)
CI No: Colour Index Number
CAS No: Chemical Abstracts Services Registry Number (USA)

UN Packing Groups:

I Dangerous goods of great danger
II Dangerous goods of medium danger
III Dangerous goods of minor danger

N.O.S.: Not otherwise specified

N.a.g.: (German for above)

N.O.I.: Not otherwise indicated (USA)

6. Toxicity

LD₅₀, LC₅₀: Result of acute toxicity tests
MAK Value: West German list of maximum airborne
contaminants
TRK: West German Technical Threshold Values
ACGIH: American Conference of Governmental
Industrial Hygienists (who publish TLVs)
TLV: Threshold Limit Value (similar to MAK)
OEL: Occupational Exposure Limit –
Listed in HSE Guidance Note EH40
MEL: Maximum Exposure Limit: – (in COSSH Regs)
to replace OEL Control limit
OES: Occupational Exposure Standard (in COSHH Regs)
to replace OEL Recommended Limit
RTECS: Register of Toxic Effects of Chemical Substances (USA)

This product should be stored, handled and used in accordance with good industrial hygiene practices and in conformity with any legal regulation. The information contained herein is based on the present state of our knowledge and is intended to describe our products from the point of view of safety requirements. It should not therefore be construed as guaranteeing specific properties.

BASF United Kingdom Limited
P.O. Box 4, Earl Road, Cheadle Hume, Cheadle,
Cheshire, SK8 6QG
Tel: 0161 485 6222 Telex: 669211 BASFCH G/Fax: 0161 486 0891

Safety Data Sheet

Sandoz Chemicals

Issue date 29/07/88

replacing data sheet issued on 06/07/88

Product Name: MELIO AQUALEN AKU
Chemical Characterisation: polyfunctional
 nitrogen - combination

1. Physical Data

- 1.1 **Melting / softening point:**
- 1.2 **Boiling point:** n.a.
- 1.3 **Decomposition temperature:**
- 1.4 **pH:** approx 11 (at g/l water)
- 1.5 **Solubility in water:** @ 20°C miscible
- 1.6 **Odour:** slight
- 1.7 **Physical form:** liquid

2. Storage Stability and Handling

- 2.1 **Special precautions on transport and storage:**
- 2.2 **Incompatible substances:** n.a.
- 2.3 **Hazardous decomposition products:** n.a.
- 2.4 **Hazardous polymerisation products:** n.a.
 - 2.4.1 **Preventative measures:**
- 2.5 **Protective precautions:** gloves, goggles, respirators
- 2.6 **Special protective measures:** Do not inhale spray.
Use respirators if ventilation is inadequate.
- 2.7 **Measures after spillage:**
- 2.8 **Disposal:** Soak up with absorbent material and dump in accordance with local Regulations.
Rinse away residues with plenty of water.

3. Ignition and Combustion data

- 3.1 **Flash point:**
- 3.2 **Extinguishing media:** water mist, carbon dioxide, dry powder, foam
- 3.3 **Special fire precautions:** none
- 3.4 **Special fire and explosion hazards:** none.

4. Toxicological Data

- 4.1 **Acute oral toxicity** LD(50) over 3000 mg/kg tested in rats
- 4.2 **Skin irritation:** irritating, tested on rabbits
- 4.3 **Eye irritation:** irritating, tested on the eyes of rabbits

5. Emergency and First Aid Procedures

Rinse immediately with plenty of water and seek medical advice

6. Ecological data

- 6.1 **Biological elimination**
- 6.2 **Fish toxicity** LD(50):
LC(0):
EC(50):
testing time:
species:
- 6.3 **Inhibition of activity of waste water bacteria**
no inhibition level:
50% inhibition level:
test procedure:

7. Additional Information

Product contains 0.3% of an amin-stabiliser.

This product should be stored, handled and used in accordance with good industrial hygiene practices and in conformity with any legal regulations. The information contained herein is based on the present state of our knowledge and is intended to describe our products from the point of view of safety requirements. It should not therefore be construed as guaranteeing specific properties.

Sandoz Chemicals, A Division of Sandoz Products Limited, Calverley Lane, Horsforth, Leeds LS18 4RP
 Telephone (0532) 584 646 Telex 557114 SANDOZ LEEDS Telefax (0532) 390063

Material Safety Data Sheet

Earnshaw Limited, Darlington Rd, Northallerton, North Yorkshire DL6 2PQ Tel: 01609 776456 Fax: 01609 780203

IDENTIFICATION: CROSSLINKER 487
C.A.S. No: Mixture

Version No 1 (August 1994)
MSDS Code No: 487AX

Product Composition

Description: Carbodiimide in organic solvent

| Component | Symbol | Risk Phrases |
|-----------------------|--------|--------------|
| Methoxypropyl acetate | | 10 |

Exposure Controls / Personal Protection

Components with occupational exposure limits:

Personal Protection: Adequate ventilation, chemical goggles, impervious gloves.

Hazard Identification

Classification: Flammable, harmful.

Risk: Irritating to eyes. Prolonged skin contact may cause irritation or sensitisation. Ingestion may cause irritation, nausea, vomiting.

Warning:

Physical and Chemical Properties

Form: Liquid

Colour: Brown

Boiling point: °C

Flash point: 45°C

Explosive Limits:

Vapour Pressure:

First Aid Measures

Eye Contact: Rinse immediately with water for at least 15 minutes. Seek medical aid urgently.

Skin Contact: Remove contaminated clothing. Wash skin with soap & water.

Ingestion: Drink plenty of water. Induce vomiting, seek medical aid.

Inhalation: Remove to fresh air.

Stability and Reactivity

Stable under normal storage conditions.
Reacts with strong mineral acids.

Fire Fighting Measures

Suitable Extinguishers: Chemical foam, powder, carbon dioxide, waterspray.

Restrictions:

Fire/explosion Hazard:

Special Equipment: Wear self-contained breathing apparatus.

Toxicological Information

Acute oral toxicity:

Inhalation:

Skin:

Eye: May cause conjunctival irritation, corneal damage.

Ingestion: Causes irritation.

Accidental Release

Safety Precautions: Wear protective clothing. Avoid sources of ignition. Ventilate area.

Environmental Precautions: Do not allow to enter waterways.

Clean-up Procedure: Allow small spills to evaporate. Cover large spills with absorbent material & place in containers for disposal; wash site with water & detergent.

Ecological Information

Toxicity Fish:

Plants:

Comments:

Handling and Storage

Storage: Keep containers closed. Store in a cool dry area with adequate ventilation.

Handling: Avoid inhalation, ingestion & contact with skin or eyes.

Disposal Considerations

Waste products may be disposed of by controlled incineration. National & local legislation concerning the disposal of waste must be complied with.

Transport Information

UN Number: 1866

EEC No:

Additional Data:

Regulatory Information (supply)

Symbol & Classification: Xn Flammable, Harmful

R-Phrases: 10, 20, 36

S-Phrases: 26

Other information:

nc = not classified

Darlington Road, Northallerton, North Yorkshire DL6 2PQ.
 Telephone: (0609) 776456. Fax: (0609) 776456 Telex 58338.
 Telegrams & Cables: Earnshaw, Northallerton

Earnshaw Ltd. Colour Finishes and Chemicals for the Leather Trade

Product: Encryl N
 Chemical Constitution: Aqueous acrylic emulsion resin
 Classification:
 CAS No. UN No.

| Hazardous Components | % | O.E.L. |
|----------------------|---|--------|
| | | |

Special Fire Fighting procedures

Special Fire Fighting Procedures:
Storage: Keep from freezing preferably not less than 5°C.
Spillage: Wash away with water before it dries.
 Alternatively soak up with sand or earth and place in suitable containers for disposal.
Waste disposal: Large quantities can be disposed by land-fill methods provided local regulations permit.

| | |
|-----------------------------|-------|
| Specific Gravity: | 1.1 |
| Solids Content (%) | 60 |
| Viscosity (CPS): | |
| Autoignition temp. (deg. C) | |
| Flash point (deg. C) | 44 |
| Boiling Point (deg. C) | 100°C |
| Explosive Limits: | |

Health Hazard Data

Effects of over exposure: Presents little health hazard in normal use.
Emergency and First Aid Procedures:
Eye contact: Wash out with clean water and seek medical attention.
Skin contact: Wash out with soap and water preferably before it dries.
Ingestion: Wash out mouth and drink plenty of water. Seek medical attention.
Special Protection Measures: Wear gloves and goggles when handling.
Risk Phrases:
Safety Phrases: S23

Material Safety Data Sheet: Stahl GB Ltd.**Product: RU4385****Description: Polyurethane Resin****Date: 18-06-90****010 Physical Data**

| | |
|--------------------------------|-------------------------|
| Solids (%): | 38-42 |
| Viscosity (20°C): | 25-35 secs F4 |
| Boiling point (°C) | Approx 100 |
| Flash point (°C) | n/a |
| pH | 7.5-8.0 |
| Solubility | Dispersable |
| Odour | Characteristic |
| Appearance | White opalescent liquid |
| Vapour pressure | - |
| Explosive limits (Vol%) | - |
| Specific gravity | 1.025 |

020 Substances Hazardous to Health

| Substance | % Range | O.E.L. |
|-----------|---------|--------|
| | | |

030 Storage and Handling

- 031 Storage:** Store in a cool well ventilated place. Do not allow to freeze.
- 032 Protection requirements:** Wear protective gloves and eye protection if splashing is likely.
- 033 Special precautions:** Avoid skin & eye contact. Adequate extraction or a respirator should be used when the product is sprayed.
- 034 Spill or leak procedure:** Absorb with sand or any suitable absorbent & transfer to closed containers for subsequent disposal. Small spillages may be flushed away with water.
- 035 Method of disposal:** Bury in accordance with local authority regulations. Employing the services of a reputable waste disposal contractor is recommended.
- 036 Environmental hazards:** Do not discharge into or allow spillages to enter drains sewers or waterways. The product may be toxic to fish & micro organisms used for water treatment.
- 037 Incompatible substances:**

Please study this material safety data sheet carefully to familiarise yourselves with any hazards and safe handling procedures associated with the product.

We also ask you to pass this information onto any of your employees, customers, clients and contractors that may become involved in handling the product.

040 Fire Hazard Data

Section not applicable.

050 Health Hazard Data

Section not applicable.

060 Emergency and First Aid Procedures

061 Inhalation: Remove affected person to fresh air. Give artificial respiration if breathing has stopped. Oxygen may be given if breathing is difficult. Seek medical attention.

062 Skin contact: Remove any contaminated clothing & wash skin thoroughly with soap and water. Seek medical advice if necessary.

063 Eye contact: Rinse immediately with plenty of water & continue rinsing for at least 15 minutes. Seek medical attention if necessary.

064 Ingestion: Rinse mouth, give plenty of water or milk to drink, induce vomiting & seek immediate medical attention.

070 Labelling Information

Symbol(s): none required

UN Number: -

Contains: n/a

080 Additional Information

The information contained in this document is based on the present state of our knowledge. It is intended to describe the safety requirements for the product and so should not be construed as guaranteeing specific properties.

Since the conditions of use for the product are outside our control, it is the user's obligation to determine the conditions of safe use.

Stahl GB Ltd,
Bakewell Rd, Loughborough, Leics. LE11 0RD.
Tel No. (0509) - 215827.
Out of hours emergency tel no. (0509) -262866

Material Safety Data Sheet

Earnshaw Limited, Darlington Rd, Northallerton, North Yorkshire DL6 2PQ Tel: 01609 776456 Fax: 01609 780203

IDENTIFICATION: ENKRATHANE M2
C.A.S. No: Mixture

Product Composition

| Description: Polyurethane resin in aqueous dispersion | | | |
|---|---------|--------|--------------|
| Component | Conc. % | Symbol | Risk Phrases |
| N-methyl-2-pyrrolidone | 13 - 15 | Xi | 36/38 |
| Triethylamine | >0.3 | Xi | 36/37 |

Hazard Identification

Classification: Irritant.
Risk: Irritating to skin and eyes.

First Aid Measures

Eye Contact: Rinse immediately with water for at least 10 minutes.
Skin Contact: Remove contaminated clothing. Wash skin with soap & water.
Ingestion: Wash out mouth with water. Give water to drink, seek medical attention.
Inhalation: Remove to fresh air. Seek medical attention.

Fire Fighting Measures

Suitable Extinguishers: Waterspray, foam, powder, carbon dioxide.
Restrictions: No restrictions.
Fire/explosion Hazard: Toxic fumes may be evolved.
Special Equipment: Self-contained breathing apparatus.

Accidental Release

Safety Precautions:
Environmental Precautions: Prevent entry to sewers or watercourses.
Clean-up Procedure: Absorb on sand or earth & place in containers for disposal. Wash small spills with water.

Handling and Storage

Storage: Keep from freezing; store between 5°C and 30°C
Handling: Avoid ingestion, & contact with skin or eyes.

Version No 1 (August 1994)
 MSDS Code No: ENM2

Exposure Controls / Personal Protection

Components with occupational exposure limits:
 Triethylamine, N-Methyl-2-pyrrolidone
Personal Protection: Goggles, gloves.

Physical and Chemical Properties

Form: White liquid
Boiling point: 100°C
Flash point: >60°C
Explosive Limits:
Vapour Pressure:
Solubility in water 20°C:
Evaporation Rate (nBAc=100):

Stability and Reactivity

Stable under normal storage conditions. Avoid contact with strong oxidising agents; may evolve toxic fumes.

Toxicological Information

Acute oral toxicity:
Inhalation: not available
Skin: not available
Ingestion: not available

Ecological Information

Toxicity Fish:
Plants:
Comments: Do not allow to enter open water.

Disposal Considerations

Waste products may be disposed of by landfill. National & local legislation concerning the disposal of waste must be complied with.

Transport Information

UN Number: nc
Additional Data:

Regulatory Information (supply)

Symbol & Classification: Xi, Irritant
R-Phrases: 36/38
S-Phrases: 24/25, 26
Other information:
 nc = not classified

n-BUTYL ACETATE

Me(CH₂)₃OAc

Risks: Flammable (R10)
Safety Precautions: Not available

Identifiers

SYNONYMS: butyl ethanoate
CHEMICAL ABSTRACTS No: 123-86-4
NIOSH No: AF 73500000
HAZCHEM CODE: 3 YE
UN No: 1123

Threshold Limit Values

USA TLV (TWA): 150 ppm (710 mg/m³)
USA TLV (STEL): 200 ppm (950 mg/m³)
UK EXPOSURE LIMITS (Recommended)
Long-term (8 hr TWA value): 150 ppm (710 mg/m³)
Short-term (10 min TWA value): 200 ppm (950 mg/m³)
WEST GERMANY
MAK: 200 ppm (950 mg/m³)
FRANCE
VME: 150 ppm (710 mg/m³)
VLE: 200 ppm (950 mg/m³)
SWEDEN
short-term limit: 200 ppm (1000 mg/m³)
long-term limit: 150 ppm (710 mg/m³)

Physical Properties

Description: Yellowish liquid with rancid odour
Boiling point: 126°C
Melting point: -73°C
Density: 0.88 at 20°C
Vapour density: 4.0
Vapour pressure: 15 mm Hg at 25°C
Flash point: 29°C (open cup)
Explosive limits: 1.4 - 7.5 %
Autoignition temperature: 421°C
Solubility: Slightly soluble in water and miscible in alcohol, ethers and hydrocarbons

Packaging and Transportation

Road Transportation
hazard warning sign 1123 flammable liquid
Hazchem Code 3 YE
Sea Transportation
IMDG Code 3121
Class 3.3
Label flammable liquid
Packaging Group III
Air Transportation
ICAO/IATA Code 1123
class 3
packaging Group III
packaging Instructions cargo 310
passenger 309
passenger aircraft max. quantity 60 litres
cargo aircraft max. quantity 220 litres

Manufacture

Butyl acetate is prepared by direct esterification of acetic acid with excess butanol

Uses

Butyl acetate is widely used as a solvent for cellulose nitrate lacquers and is an active solvent for cellulose acetate butyrate, ethyl cellulose, chlorinated rubber, polystyrene, methacrylate resins and natural gums. It is used as a solvent in the preparation of artificial leather, textiles, plastics, safety glass, and photographic film, and as an extraction solvent in processing various oils and pharmaceuticals. It is also used in synthetic flavouring agents, industrial synthetic flavouring agents, industrial synthetic raw materials, and larvicides.

Chemical hazards

Butyl acetate is fairly flammable, creating a fire risk if moderately heated or in contact with a source of ignition. It reacts violently with potassium *tert*-butoxide causing ignition (1,2)

Biological hazards

The principle hazards of butyl acetate result from its irritancy to eyes, throat and nose. At high levels of exposure this may be followed by the gradual onset of narcosis, with slow recovery after termination of the exposure (3). Anaemia has been observed in workers exposed to this solvent (4). Mixtures of solvents containing butyl acetate have produced lesions and degenerative changes in the liver of rabbits (5) and significant impairment in behavioural function tests in humans (6).

n-Butyl acetate : Page 2**Biological Hazards (cont.)****Vapour Inhalation**

The vapours irritate the upper respiratory tract, irritation being mild on brief exposure to 200-300 ppm (7,8) and marked at 3,300 ppm (9). Inhalation of the vapours may also lead to headaches, dizziness, and nausea. No anaesthetic symptoms developed during exposure to 400-600 ppm for 2-3 hours. In humans there are reports concerning exposure to butyl acetate in polyester lacquers, with symptoms of nervous, respiratory and cardiovascular disorders (10). Rats exposed to a calculated air concentration of approximately 14,000 ppm for 5 hours developed narcosis and died.

Eye Contact

Eye irritation has been reported on exposure to 200 - 300 ppm (11). The liquid will also irritate the eyes and may lead to conjunctivitis.

Skin Contact

Injury from direct skin contact is of low magnitude and heals within a day (12). Prolonged or repeated exposure may lead to defatting or cracking of the skin, but there is no evidence of skin penetration at dose as high as 10 ml/kg.

Swallowing

Butyl acetate is of low oral toxicity to laboratory animals, but will cause irritation and act as a central nervous system depressant. The oral LD₅₀ (rats) is 14.0 g/kg (13).

Carcinogenicity

Increased rates of multiple myeloma have been reported in workers exposed to a mixture of solvents, including butyl acetate, in the paint manufacturing industry although it is uncertain whether this is due to exposure to butyl acetate (14).

Mutagenicity

Tests of the mutagenicity of butyl acetate in the *Salmonella typhimurium* and *Escherichia coli* assay systems gave negative results (15,16).

Reproductive Hazards

Butyl acetate was embryotoxic but not teratogenic when administered to pregnant mice (17).

First Aid**Eyes**

In cases of contact with the liquid or vapours wash the eyes with water or neutral saline solution for at least 15 minutes. Remove contact lenses if worn. If irritation still occurs seek medical advice.

Lungs

Remove the victim from the contamination immediately to fresh air; keep warm and at rest (in the recovery position). If breathing is weak, irregular or has stopped, commence artificial respiration. Oxygen may be beneficial.

Mouth

Rinse mouth with water and if swallowed dilute with water. Do not induce vomiting.

Skin

Remove contaminated clothing and wash the affected area with soap and water.

Handling and Storage

Butyl acetate should be stored in a flammable-liquids store and away from sources of ignition or direct sunlight in a well-ventilated place. As vapours are heavier than air they can accumulate and travel to sources of ignition and flash back. Large quantities should be stored in metal tanks or drums. Protective clothing should be worn especially eye protection (goggles or face shield) and natural rubber or neoprene (not PVC) gloves.

Disposal

Shut off all sources of ignition. Wear eye and skin protection and have breathing apparatus available. Small quantities may be absorbed on paper and evaporated in a fume cupboard (do not pour into drains as explosive concentrations may develop). Large quantities should be absorbed on to sand and taken to a safe area for evaporation or burial. Ideally, butyl acetate should be disposed of in a chemical incinerator with appropriate precautions.

Fire Precautions

Dry powder, alcohol-resistant foam, halon or carbon dioxide extinguishers should be used for small fires. Large spills or tank fires are best controlled by alcohol resistant foam. Small fires can also be extinguished with plenty of water, and water sprays are useful for cooling containers near a fire.

Further Reading

Sax, N. Irving *Dangerous Properties of Industrial Materials* (6th edition)
Bretherick, L. *Hazards in the Chemical Laboratory* (4th edition)
Bretherick, L. *Handbook of Reactive Chemical Hazards* (3th edition)
Encyclopaedia of Occupational Safety & Health
Patty's *Industrial Hygiene and Toxicology*
Kirk-Othmer *Encyclopedia of Chemical Technology*
National Fire Protection Association *Manual of Hazardous Reactions*

References

1. Manwaring, R.; et al. *Chem. & Ind.* 1973, 172
2. Spink, D.J. *Chem. Ind. (London)* 1973 **4**, 172
3. Browning, E. *Toxicity and Metabolism of Industrial Solvents*. Elsevier, 1965, pp 529 - 532, 591 - 593
4. Shalaby, E.S. *J. Egypt Med. Assoc.* 1973, **53**(4/5), 340 - 347
5. Querci, V. *Med. Lav.* 1970, **10**(10), 524 - 530
6. Binashi, S.; et al. *Adverse Eff. Environ. Chem. Psychotropic Drugs*, 1976, **3**, 91 - 98
7. Von Oettingen, W. F. *Arch. Ind. Health*, 1960, **21**, 28
8. Sayers, R. R.; et al. *U.S. Publ. Health Rep.* 1936, 51, 1229
9. Nelson, K. W.; et al. *J. Ind. Hyg. Tox.* 1943, **25**, 285
10. Titova, N. N.; Zakirova, R. G. *Kazan Med. Zh.* 1977, **58**(1). 36
11. Sterner, J.H.; et al. *Am Ind. Hyg. Assoc. Quart* 1949, **10**, 53
12. McLaughlin, R. S. *Am. J. Ophthalmol.* 1946, **29**, 361
13. Smyth, Jr., H. F.; et al. *Arch. Ind. Hyg. Occup. Med.* 1954, **10**, 61 - 68
14. Lundberg, I. *Scand. J. Work, Environ. Health*, 1986, **12**(2), 108 - 113
15. Shimizu, H.; et al. *Sangyo Igaku* 1985, **27**(6), 400 - 419
16. Ishidate, M.; et al. *Food Chem. Toxicol.* 1984, **22**(8), 623 - 636
17. Scheufler, H. *Biol Rundsch.* 1976, **14**(4), 227 - 229

Butanol

Me(CH₂)₃OH

Risks: Flammable – harmful by inhalation (R10, R20)
Safety Precautions: Keep away from sources of ignition – no smoking (S16)

Identifiers

SYNONYMS: *n*-butyl alcohol, butyric alcohol, propylcarbinol, propylmethanol, 1-hydroxybutane, butyl hydroxide

CHEMICAL ABSTRACTS No: 71-36-3

NIOSH No: EO 1400000

HAZCHEM CODE: 3 Y

UN No: 1120

Threshold Limit Values

USA TLV (TWA): ceiling limit 50 ppm (150 mg/m³)

USA TLV (STEL): not available

UK EXPOSURE LIMITS (Recommended)

Long-term (8 hr TWA value): 50 ppm (150 mg/m³)

Short-term (10 min TWA value): 50 ppm (150 mg/m³)

WEST GERMANY

MAK: 100 ppm (300 mg/m³)

FRANCE

VME: not available

VLE: 50 ppm (150 mg/m³)

SWEDEN

ceiling limit: 50 ppm (150 mg/m³)

long-term limit: 25 ppm (80 mg/m³)

Manufacture

Butanol used to be produced by fermentation, but is now produced on a manufacturing scale by the "oxo" process where propylene is treated with carbon monoxide and hydrogen to produce butyraldehyde and isobutyraldehyde in a proportion of 3 to 1, although this is dependent on the cobalt or rhodium catalysts used. The butyraldehydes are converted to the alcohols by reduction and separated. Butanol is also produced by the aldol process through the reaction of acetaldehyde with base to produce acetaldol which, on acidification, produces crotonaldehyde (2-butenal), which may be converted to butanol by catalytic hydrogenation. Ethanol may be directly converted to butanol using magnesium-copper oxide catalysts at 325°C and 125 atmospheres.

Physical Properties

Description: Colourless liquid with rancid odour

Boiling point: 117.5°C

Melting point: -88.9°C

Density: 0.809 at 20°C

Vapour density: 2.55

Vapour pressure: 5.5 mm Hg at 20°C

Flash point: 29°C (open cup)

Explosive limits: 1.4 - 11.2 %

Autoignition temperature: 345°C

Solubility: (8% w/v) in water but miscible with most organic solvents.

Packaging and Transportation

Road Transportation

hazard warning sign 1120 flammable liquid

Hazchem Code 3 Y

Sea Transportation

IMDG Code 3120

class 3.3

label flammable liquid

packaging group iii

Air Transportation

ICAO/IATA Code 1120

class 3

packaging group iii

packaging instructions cargo 310

passenger 309

passenger aircraft max. quantity 60 litres

cargo aircraft max. quantity 220 litres

Uses

Butanol is used as a cosolvent with butyl acetate for nitrocellulose in lacquers, and as a solvent for fats, waxes, shellac, resins, gums, varnishes, and urea-formaldehyde foams. It is used in the manufacture of butyl acetate, butyl acrylate, detergents, and rayon. It is used as a diluent for brake fluids and as an extraction medium in pharmaceutical synthesis of antibiotics, vitamins, and hormones. Isobutanol and butanol have interchangeable uses in their solvent properties.

Chemical Hazards

Butanol is a flammable liquid. It reacts with finely divided chromium trioxide vigorously causing ignition (1). Butanol attacks aluminium forming alkoxides and reacts with oxidising agents. *n*-Butanol is more ignitable than other butyl alcohols (2).

Biological Hazards

Butanol is readily absorbed through the skin, by inhalation, and through the gastrointestinal tract (3). It is metabolised by alcohol dehydrogenase via butyraldehyde to butanoic acid and is mainly eliminated as carbon dioxide. It is irritating to the eyes and moderately irritating to the skin. Vapours are irritating to the respiratory tract and cause central nervous system depression. The most likely acute effects are alcoholic intoxication and narcosis, with liver and kidney damage from repeated exposure.

Vapour Inhalation

It has been calculated that concentrations of 1268 ppm of butanol vapours would be intolerable, based on irritancy to the respiratory tract (4). Vapours of butanol cause central nervous system depression and narcosis: the solvent is six times more toxic than ethanol. Symptoms of headache, drowsiness, and vertigo have been reported (5), which were reversible on cessation of exposure.

Eye Contact

Butanol may cause severe corneal irritation from vapours or the liquid. Vapours have also caused burning sensations, lachrymation, blurred vision and photophobia (6).

Skin Contact

Butanol will cause defatting of the skin resulting in dermatitis. It is moderately irritating and will be absorbed through the skin.

Swallowing

Following ingestion, symptoms of alcoholic intoxication and narcosis may be anticipated. Following repeated exposure, degeneration of the liver and kidneys are noted with effects on the lungs and the blood (7).

Carcinogenicity

No adequate data on the carcinogenicity of butanol are available.

Mutagenicity

In the Ames *Salmonella typhimurium* mutagenicity assay, butanol produces negative results (8). It does not affect sister chromatid exchange in Chinese hamster ovary cells *in vitro* (9).

Reproductive Hazards

No relevant data on the effects of butanol on reproduction, embryotoxicity or teratogenicity have been identified.

First Aid

Eyes

Flush immediately with water or neutral saline solution for at least 15 minutes. Seek medical attention.

Lungs

Remove the victim to fresh air. If breathing is weak, irregular or has stopped, apply artificial respiration. Oxygen may be beneficial.

Mouth

Do not induce vomiting and seek immediate attention. Avoid alcoholic drinks as these may enhance toxic effects.

Skin

Remove contaminated clothing and rinse contaminated area with soap and water. If skin irritation persists seek medical attention.

Handling and Storage

Store away from sources of heat and away from direct sunlight and sources of ignition. Wear gloves, eye protection, and boots.

Disposal

Shut off all sources of ignition and wear protective clothing. Absorb small spills onto paper and remove to a safe area for burning or burying. Flush the contaminated area with plenty of water. For large spills, absorb with sand or vermiculite and remove to a safe place for burning or burying. Incineration is the recommended method of disposal.

Fire Precautions

Use dry chemical powder extinguishers, especially near electrical equipment. Carbon dioxide, alcohol-resistant foams, or water spray may also be used. Water spray may be useful to keep containers cool near a fire.

Further Reading

Sax, N. Irving *Dangerous Properties of Industrial Materials* (6th edition)
Encyclopaedia of Occupational Safety & Health
Patty's *Industrial Hygiene and Toxicology*
Kirk-Othmer *Encyclopedia of Chemical Technology*
National Fire Protection Association *Manual of Hazardous Reactions*
ACGIH *Documentation of TLVs and BEIs* (6th edition) (1986)
Bretherick, L. *Handbook of Reactive Chemical Hazards* (3th edition)
Environmental Health Criteria No. 65: Butanols UNEP/ILO/WHO (1987)

References

1. Newth, F. H. *Chem. Ind.* (London) 1964, 1482
2. Kishore, K. *Def. Sci. J.* 1978, **28**, 13-14
3. Wartburg, J. P.; et al. *Biochemistry* 1964, **3**, 1775-1782
4. De Ceaurriz, J. C. *Toxicol. Lett.* 1981, **9**, 137-143
5. Seitz, B. *Arch. Mal. Prof. Med. Trav. Secur. Soc.* 1972, **33**, 393-395
6. Sterner, J. H. *Am. Ind. Hyg. Assoc. Quart* 1949, **10**, 53-59
7. Rumyanstev, A. P. *Gig. Sanit.* 1976, **11**, 12-15
8. McCann, J.; et al. *Proc Natl. Acad. Sci. (USA)* 1975, **72**, 5735-5739
9. Obe, G. *Mutat. Res.* 1977, **55**, 211-213

Methyl Ethyl Ketone

MeCOEt

Risks: Highly flammable (R11)

Safety Precautions: Keep container in a well-ventilated place – keep away from sources of ignition – no smoking – do not breath vapour – take precautionary measures against static discharges (S9, S16, S23, S33)

Identifiers

SYNONYMS: 2-butanone, methyl acetone, MEK, butan-2-one

CHEMICAL ABSTRACTS No: 78-93-3

NIOSH No: EL 6475000

HAZCHEM CODE: 2 YE

UN No: 1193

Threshold Limit Values

USA TLV (TWA): 200 ppm (590 mg/m³)

USA TLV (STEL): 300 ppm (885 mg/m³)

UK EXPOSURE LIMITS (Recommended)

Long-term (8 hr TWA value): 200 ppm (590 mg/m³)

Short-term (10 min TWA value): 300 ppm (885 mg/m³)

WEST GERMANY

MAK: 200 ppm (590 mg/m³)

FRANCE

VME: 200 ppm (600 mg/m³)

VLE: not available

SWEDEN

ceiling limit: 100 ppm (300 mg/m³)

long-term limit: 200 ppm (600 mg/m³)

Manufacture

Methyl ethyl ketone was formerly produced by the destructive distillation of wood, but nowadays is mainly obtained from petroleum by the dehydrogenation of 2-butanol. It can also be obtained by fermentation, or by heating methyl acetoacetate with dilute sulphuric acid under reflux.

Uses

Methyl ethyl ketone is used principally as a solvent (sometimes in mixed solvent systems) for cellulose acetate and nitrate, gums, resins (e.g. epoxy resins), lacquers, varnishes, oils and fats, pigments and dyes, vinyl polymers and copolymers, and in paint removers and dewaxers. It is also used as a chemical intermediate in synthesis and in the manufacture of pharmaceuticals, cosmetics, adhesives, paints, plastics, smokeless powder and explosives, synthetic rubber, artificial silk and leather, cement, lubricating oils, hydraulic fluid, aeroplane dopes, printing inks and catalysts.

Physical Properties

Description: Colourless liquid with irritating odour similar to acetone

Boiling point: 79.57°C

Melting point: -85.9°C

Density: 0.8061 at 20°C

Vapour density: 2.5

Vapour pressure: 71.2 mm Hg at 20°C

Flash point: -6°C (open cup)

Explosive limits: 1.9 - 11 %

Autoignition temperature: 516°C

Solubility: Soluble in water at up to 25% by volume, miscible with ethanol, ether, benzene and many oils.

Packaging and Transportation

Road Transportation

hazard warning sign 1193 flammable liquid

Hazchem Code 2 YE

Sea Transportation

IMDG Code 3080

class 3.2

label flammable liquid

packaging group ii

Air Transportation

ICAO/IATA Code 1193

class 3

packaging group ii

packaging instructions cargo 307

passenger 305

passenger aircraft max. quantity 5 litres

cargo aircraft max. quantity 60 litres

Chemical Hazards

Methyl ethyl ketone is a dangerous fire and explosion risk when exposed to heat or flame, but its vapours can be detected by their odour at less than 25 ppm and are intensely irritating at 350 ppm, so that fire hazards should be recognisable before vapours become flammable. It reacts violently with oxidising materials, e.g. oleum, chlorosulphonic acid, and potassium tert-butoxide (1). A vigorous reaction also takes place with chloroform in the presence of bases (2). The peroxide is formed by reaction with hydrogen peroxide/nitric acid (3), and this can react violently with many organic materials, especially acetone.

Methyl Ethyl Ketone : Page 2

Biological Hazards

Methyl ethyl ketone is only slightly toxic, being regarded industrially, with acetone, as a relatively safe solvent (5). Care should be taken however to avoid vapour concentrations building up by provision of adequate ventilation. MEK is reduced to some extent in the body to 2-butanol, which is probably excreted as the glucuronide. MEK may enhance the toxicity of other solvents in mixed solvent systems, e.g. the neurotoxicity of hexane is enhanced by MEK (6).

Vapour Inhalation

MEK causes irritation to the respiratory tract at 100 ppm, irritation to the eyes at 200 ppm, headaches at 300 ppm, and symptoms of central nervous system depression (dizziness, drowsiness, incoordination) and nausea and vomiting at above 500 ppm.

Eye Contact

The liquid irritates the eyes and may cause corneal damage.

Skin Contact

Minor contact only causes some irritation, but repeated or prolonged contact can lead to defatting of the skin, leading to cracking, secondary infection, and dermatitis. Some people may become sensitized. The use of neoprene or natural rubber gloves, or barrier creams will reduce skin contact. Rabbit dermal LD₅₀ is 13,000 mg/kg.

Swallowing

The solvent has low acute oral toxicity, but may cause gastric irritation. High doses can lead to narcosis.

Carcinogenicity

There is no information available to assess the carcinogenic potential of methyl ethyl ketone.

Mutagenicity

Testing of methyl ethyl ketone for mutagenicity by bacterial mutation assays, mitotic gene conversion assays and chromosomal aberrations gave negative results (7).

Reproductive Hazards

Methyl ethyl ketone, in inhalation experiments in pregnant rats, induced maternal toxicity with slight foetotoxicity and in creased incidence of skeletal variants. Inhaled methyl ethyl ketone at exposure levels of 300 ppm causes either in creased embryotoxicity or teratogenic responses (8,9).

First Aid**Eyes**

In cases of contact with the liquid or vapours wash the eyes with water or neutral saline solution for at least 15 minutes. Remove contact lenses if worn. If irritation still occurs seek medical advice.

Lungs

Remove the victim from the contamination immediately to fresh air; keep warm and at rest (in the recovery position). If breathing is weak, irregular or has stopped, commence artificial respiration. Oxygen may be beneficial.

Mouth

Rinse mouth with water and if swallowed dilute with water. Do not induce vomiting.

Skin

Remove contaminated clothing and wash the affected area with soap and water.

Handling and Storage

Should be stored in a flammable-liquids store and away from sources of ignition or direct sunlight in a well-ventilated place. As vapours are heavier than air, they can accumulate and travel back to sources of ignition and flash back. Large quantities should be stored in metal tanks or drums. Protective clothing should be worn, especially eye protection (goggles or face shield) and natural rubber or neoprene (not PVC) gloves.

Disposal

Shut off all sources of ignition. Wear eye and skin protection and have breathing apparatus available. Small quantities may be absorbed on paper and evaporated in a fume cupboard (do not pour into drains as explosive concentrations may develop). Large quantities should be absorbed on to sand and taken to a safe area for evaporation or burial. Ideally, the solvent should be disposed of in a chemical incinerator with appropriate precautions.

Fire Precautions

Dry powder, alcohol-resistant foam, halon, or carbon dioxide extinguishers should be used for small fires. Large spills or tank fires are best controlled by alcohol-resistant foam. Small fires can also be extinguished with plenty of water, and water sprays are useful to cool containers near fire.

Further Reading

Sax, N. Irving *Dangerous Properties of Industrial Materials* (6th edition)
Encyclopaedia of Occupational Safety & Health
Patty's Industrial Hygiene and Toxicology
Kirk-Othmer Encyclopedia of Chemical Technology
National Fire Protection Association Manual of Hazardous Reactions
ACGIH Documentation of TLVs and BEIs (6th edition) (1986)
FPA Information Sheets on Hazardous Materials. H16. Methyl Ethyl Ketone (1978)
Hazard Data Bank Sheet 8. Ketones. Paramount Publishing (1978)
NIOSH Criteria for a Recommended Standard Occupational Exposure to Ketones (1978)
Ethel Browning's Toxicity and Metabolism of Industrial Solvents (1965)

References

1. Manwaring, R. *Chem. Ind.* 1973, 172
2. Ekely, J. P.; et al. *J. Am. Chem. Soc.* 1924, **46**, 1253
3. Bjorklund, G. H.; et al. *Trans. Roy. Soc. Can.* 1950, **44**, 25
4. Venable, E. *Chem. Eng. News* 1982, **60**(42), 94
5. Henson, E. V. *JOM J. Occup. Med.* 1959, **1**, 607
6. Takeuchi, Y.; et al. *Br. J. Ind. Med.* May 1983, **40**(2), 199-203
7. Brooks, T. M.; et al. *Mutagenesis* 1988, **3**(3), 227-232
8. Deacon, M. M.; et al. *Toxicol. Appl. Pharmacol.* 1981, **59**, 620
9. Schwetz, B. A.; et al. *Toxicol. Appl. Pharmacol.* 1974 **28**(3), 452-464

Ethylene Glycol Monoethyl Ether : Page 2**Biological Hazards (cont.)****Vapour Inhalation**

Vapours of ethylene glycol monoethyl ether are irritating to the eyes, mucous membranes and upper respiratory tract but should not be irritant at levels considered safe for prolonged and repeated exposures. In animal experiments, toxic effects to the blood, liver, kidney, central nervous system and reproductive system have been observed at levels above 300 ppm, with adverse effects on the reproductive system at levels as low as 10 ppm.

Eye Contact

In contact with the eye, the liquid produces immediate pain and corneal and conjunctival irritation which clears within 24 hours. It is regarded equally as irritant as ethyl alcohol (2).

Skin Contact

Repeated, prolonged contact of ethylene glycol monoethyl ether to the skin produces no more than mild irritation and reddening. It is, however, absorbed through the skin in toxic amounts producing toxic effects in the blood, kidneys and the central nervous system.

Swallowing

Causes gastric irritation and damage to the kidneys and the liver. In animal studies typical toxic effects on the kidney, blood, central nervous system, and to the testes are reported.

Carcinogenicity

No information available on the carcinogenicity of ethylene glycol monoethyl ether (3).

Mutagenicity

It is not mutagenic by the Ames Salmonella typhimurium mutagenicity assay (4).

Reproductive Hazards

In laboratory animals and human exposures, ethylene glycol monoethyl ether has been shown to cause a decrease in sperm count, sperm abnormalities, and a degeneration of the testes (5,6,7). Significant maternal toxicity, embryotoxic effects, and teratogenicity have been established (8,9).

First Aid**Eyes**

In case of contact with the liquid, wash with water or neutral saline solution for at least 15 minutes. Seek medical attention.

Lungs

Remove the victim away from the source of contamination to fresh air. If breathing is weak, irregular or has stopped begin artificial respiration. Oxygen may be beneficial.

Mouth

Do not induce vomiting, due to the risk of aspiration of the liquid into the lungs, which will cause chemical pneumonitis.

Skin

Skin contact is not immediately hazardous. Wash off with soap and water.

Handling and Storage

Should be stored in tightly closed containers in a cool area with adequate ventilation and away from sources of ignition. It should be stored away from incompatible chemicals such as oxidizing agents, strong acids or alkalis. Protective clothing should be worn to prevent excessive skin contact, and goggles or other eye protection should always be worn. Gloves made of PVA are recommended for short periods; PVC and nitrile gloves give excellent protection.

Disposal

Provide adequate ventilation and use appropriate protective clothing and respiratory protection. Make sure there are no sources of heat or ignition before attempting to clean up a spill. For small spills absorb onto paper and burn in an incinerator. Large spills may be absorbed onto sand and disposed of by landfill.

Fire Precautions

Use carbon dioxide, dry chemical or alcohol-resistant foam extinguishers for fires involving ethylene glycol monoethyl ether. Water is not generally suitable as it will spread the fire, but may be useful for cooling containers.

Ethylene Glycol Monoethyl Ether : Page 3**Further Reading**

Sax, N. Irving *Dangerous Properties of Industrial Materials* (6th edition)
Encyclopaedia of Occupational Safety & Health
Patty's Industrial Hygiene and Toxicology
Kirk-Othmer Encyclopedia of Chemical Technology
National Fire Protection Association Manual of Hazardous Reactions
ACGIH Documentation of TLVs and BEIs (6th edition) (1986)
Illing, H. P. A. *Toxicity Review No. 10 Glycol Ethers* HSE (1985)

References

1. Darnall, D. W. *Chem. Eng. News* 1978, **56**(47), 47
2. Carpenter, C. P. *Am. J. Ophthalmol.* 1946, **29**, 1 363-1372
3. Melnick, R. L. *Environ. Health Perspect.* 1984, **57**, 147-155
4. McGregor, D. 8. *Environ Health Perspect.* 1984, **57**, 97-103
5. Foster, P. M. D. *Toxicol. Appl. Pharmacol.* 1983, **69**, 385-399
6. Hardin, B. D. *Toxicology* 1983, **27**, 91-102
7. Nagano, K. *Toxicology* 1981, **20**, 335-343
8. Lamb, J. C. *Environ. Health Perspect.* 1984, **57**, 85-90
9. Doe, J. E. *Environ. Health Perspect.* 1984, **57**, 33-41

Material Safety Data Sheet

Earnshaw Limited, Darlington Rd, Northallerton, North Yorkshire DL6 2PQ Tel: 01609 776456 Fax: 01609 780203

IDENTIFICATION: METHOXYPROPANOL
C.A.S. No: 107-98-2

Version No 1 (June 1994)
MSDS Code No: M104

Product Composition

| Description: | | | |
|--------------|---------|--------|--------------|
| Component | Conc. % | Symbol | Risk Phrases |
| | | | |

Exposure Controls / Personal Protection

Components with occupational exposure limits:
Methoxypropanol can be absorbed through skin.
Personal Protection: Adequate ventilation, goggles, gloves.

Hazard Identification

Classification: Flammable
Risk: Moderately irritating to skin & eyes. Inhalation of vapour may produce drowsiness, unconsciousness. May be absorbed through intact skin.

Physical and Chemical Properties

Form: Clear liquid
Boiling point: 120°C
Flash point: 35°C
Explosive Limits:
Vapour Pressure:
Solubility in water 20°C:
Evaporation Rate (nBAC=100):

First Aid Measures

Eye Contact: Rinse immediately with water for at least 10 minutes.
Skin Contact: Remove contaminated clothing. Wash skin with soap & water.
Ingestion: Wash out mouth with water. Drink plenty of water.
Inhalation: Remove to fresh air. Seek medical aid if exposure is prolonged.

Stability and Reactivity

Stable under normal storage conditions. Avoid contact with strong oxidising agents.

Fire Fighting Measures

Suitable Extinguishers: Chemical foam, powder, carbon dioxide.
Restrictions: Waterspray.
Fire/explosion Hazard:
Special Equipment:

Toxicological Information

Acute oral toxicity: LD₅₀ ORL-RAT: 6.6G/KG
Inhalation: High concentrations irritate eyes, nose & throat, & may produce loss of consciousness.
Skin: Prolonged contact may cause irritation.
Ingestion: Depresses central nervous system.

Accidental Release

Safety Precautions: Ensure adequate ventilation. Extinguish sources of ignition.
Environmental Precautions:
Clean-up Procedure: Cover with absorbent material & place in containers for disposal.

Ecological Information

Toxicity Fish:
Plants:
Comments: Do not allow to enter open water.

Handling and Storage

Storage: Keep containers closed. Store in a cool dry area away from sources of ignition, with adequate ventilation.
Handling: Avoid inhalation, ingestion, & contact with skin or eyes.

Disposal Considerations

Waste products may be disposed of by controlled incineration. National & local legislation concerning the disposal of waste must be complied with.

Transport Information

UN Number: 1993
EEC No: 2: 203-539-1

Regulatory Information (supply)

Symbol & Classification: Flammable
R-Phrases: 10
S-Phrases: 24
Other information:
nc = not classified

Xylene

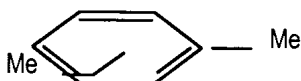

Risks: Flammable – harmful by inhalation (R10, R20)

Safety Precautions: Avoid contact with skin and eyes (S24/25)

Identifiers

SYNONYMS: dimethylbenzene, xylol, dilan

CHEMICAL ABSTRACTS No:

General 1330-20-7
ortho 95-47-6
meta 108-38-3
para 106-42-3

NIOSH No: ZE 2100000
 Commercial xylene ZE 2190000
o-xylene ZE 2450000
m-xylene ZE 2275000
p-xylene ZE 2450000

HAZCHEM CODE: 3 Y

UN No: 1307

Threshold Limit Values

USA TLV (TWA): 100 ppm (435 mg/m³)

USA TLV (STEL): 150 ppm (655 mg/m³)

UK EXPOSURE LIMITS (Recommended)

Long-term (8 hr TWA value): 150 ppm (650 mg/m³)

Short-term (10 min TWA value): not available

WEST GERMANY

MAK: 100 ppm (440 mg/m³)

FRANCE

VME: 150 ppm (650 mg/m³)

VLE: not available

SWEDEN

ceiling limit: 50 ppm (200 mg/m³)

Manufacture

Xylene is produced principally by catalytic reforming of petroleum refinery fractions, followed by extraction of the aromatics. It is less frequently produced from coal tar fractions. Commercial xylene is a mixture of isomers and may also contain significant amounts of benzene and ethylbenzene.

Uses

Xylene is used as a solvent for gums, rubbers, oils, and epoxy and other resins and as an intermediate in the manufacture of organic chemicals, e.g. xylenes,

Physical Properties

Description: Colourless liquid with aromatic odour

Boiling point: 137 - 140°C

Melting point: -30°C

Density: 0.86 at 20°C

Vapour density: 3.7

Vapour pressure: 6.72 mm Hg at 21°C

Flash point: 15 - 55°C

Explosive limits: 1.1 - 7%

Autoignition temperature: 490 - 550°C

Solubility: Insoluble in water but miscible with most organic solvents, including diethyl ether and ethanol.

Packaging and Transportation

Road Transportation

hazard warning sign 1307 flammable liquid

Hazchem Code 3 Y

Sea Transportation

IMDG Code 3113 (flashpoint below 21°C)

..... 3158 (flashpoint 22 - 25°C)

class 3.2, 3.3

label flammable liquid

packaging group ii, iii

Air Transportation

ICAO/IATA Code 1307

class 3

packaging group II, III

packaging instructions cargo 310

passenger 309

passenger aircraft max. quantity

II 5 litres

III 60 litres

cargo aircraft max. quantity

II 60 litres

III 220 litres

benzoic acid, phthalic anhydride, and isophthalic and terephthalic acids and their esters (used in the manufacture of plastics and synthetic textiles). It is also used in the manufacture of paints, dyes, xylene-formaldehyde resins, pharmaceuticals, insecticides, perfumes, vitamins, hydrogen peroxide, and quartz crystal oscillators. Xylene is frequently encountered in the laboratory in the preparation of tissue specimens for histological purposes and as an oil-immersion medium and cleaning agent in microscopy. Finally, xylene finds use as a high-quality octane-blending agent in motor and aviation fuels.

Chemical Hazards

It is moderately flammable in the presence of heat or flame and can react with oxidising materials. Special care should be taken during aerobic or nitric acid oxidations of p-xylene to terephthalic acid (1).

Biological Hazards

Xylene probably has the same toxicity as that of toluene. Commercial xylene often contains benzene as an impurity and this can lead to blood disease, not observed with pure xylene. Xylene is prohibited for general use in the UK if it contains more than 1% benzene. There is no detectable difference between the toxicities of the xylene isomers. Metabolism is principally by oxidation of the methyl group to toluic acids followed by conjugation with glycine to methylhippuric acids. These conjugates are excreted in the urine and their urine levels can be used to monitor exposure (2-4). Drinking alcohol in conjunction with exposure to xylene increases the effects of alcohol and impairs the clearance of xylene (5). Xylene accumulates in adipose tissue, from which it is slowly released. Complete clearance of xylene from the body may take several days following exposure (6,7).

Vapour Inhalation

The principal effects of xylene are narcotic: any blood changes are due to benzene impurities (8). Acute exposure to more than 200 ppm or chronic exposure to 100-200 ppm may lead to headaches, mental irritation and confusion, drowsiness, nausea, vomiting, cough and catarrh, and irritation of the skin and eyes. No chronic organ toxicity has been observed: any kidney and liver damage is reversible. Abnormal heart beat in a laboratory worker has been associated with long-term exposure to xylene (9). Exposure to very high concentrations (greater than 10,000 ppm) has caused unconsciousness, due to depression of the central nervous system, and at least one death (10).

Eye Contact

Both the liquid and vapours act as eye irritants and repeated exposure to the vapours can lead to reversible corneal changes and conjunctivitis.

Skin Contact

The liquid is a skin irritant, and continued or repeated contact can cause defatting of the skin with dermatitis. Xylene is absorbed slowly through the skin, but absorption is enhanced when the skin is damaged.

Swallowing

Ingestion produces similar effects to vapour inhalation. Oral LD₅₀ (rat) 4300 mg/kg. The liquid causes damage to stomach and intestinal linings.

Carcinogenicity

From available evidence, xylene is not carcinogenic nor damaging to genetic material. Due to its effect on skin, xylene may enhance the effect of known carcinogens.

Mutagenicity

In various studies xylene was not mutagenic [11].

Reproductive Hazards

The available information indicates that xylene is not teratogenic, but can be toxic to the embryo or foetus and may reduce fertility (12). In animal tests, high doses of xylene have caused reduced litter sizes, retarded development of the foetus, and increased incidence of nonlethal abnormalities (13,14).

First Aid

Eyes

In cases of contact with the liquid or vapours, wash the eyes with water or neutral saline solution for at least 15 minutes. Remove contact lenses if worn. If irritation still occurs, seek medical advice.

Lungs

Immediately remove the victim from the contamination to fresh air; keep warm and at rest (in the recovery position). If breathing is weak, irregular or has stopped, commence artificial respiration. Oxygen may be beneficial.

Mouth

Rinse mouth with water and if swallowed dilute with water. Do not induce vomiting as this may increase the risk of aspiration of the liquid into the lungs causing chemical pneumonitis. Consumption of non-oily liquids (such as milk) may assist in delaying absorption of xylene.

Skin Remove contaminated clothing and wash the affected area with soap and water.

Handling and Storage

Store in a well-ventilated flammable-liquid store, free from sources of ignition. Xylene is not corrosive to metals and hence large quantities can be stored in iron, mild steel, or aluminium containers; small quantities may be kept in laboratories in glass containers. Avoid breathing the vapour and contact of the liquid with the skin, wearing protective clothing where necessary. Clothing made with nitriled rubber, acrylonitrile rubber and certain neoprene rubber materials can resist xylene penetration and Viton and PVA materials provide good protection. Xylene vapour is much heavier than air and may travel considerable distances to a source of ignition and flash back.

Xylene : Page 3

Disposal

Shut off all sources of ignition. Wear eye and skin protection and have breathing apparatus available. Small quantities may be absorbed on paper and evaporated in a fume cupboard. Large quantities should be absorbed onto sand and taken to a safe area for evaporation. Xylene may be used as a boiler fuel or disposed of in an incinerator with appropriate precautions. It may also be discharged into sewers in small quantities using emulsifying agents and excess of water.

Fire Precautions

Dry powder, alcohol-resistant foam, halon, or carbon dioxide extinguishers should be used for small fires. Large spills or tank fires are best controlled by alcohol-resistant foam. Small fires can also be extinguished with plenty of water and water sprays are useful to cool containers near a fire.

Further Reading

- Sax, N. Irving *Dangerous Properties of Industrial Materials* (6th edition)
Encyclopaedia of Occupational Safety & Health
Patty's *Industrial Hygiene and Toxicology*
Kirk-Othmer *Encyclopedia of Chemical Technology*
National Fire Protection Association *Manual of Hazardous Reactions*
ACGIH *Documentation of TLVs and BEIs* (6th edition) (1986)
Ethel Browning's *Toxicity and Metabolism of Industrial Solvents* 2nd edition (Elsevier 1987)
Bretherick, L. *Hazards in the Chemical Laboratory* (4th edition)
Bretherick, L. *Handbook of Reactive Chemical Hazards* (3rd edition)
WHO Recommended Health-based Limits in Occupational Exposure to Selected Organic Solvents. Xylene. Technical Report Series 664 (1981)
Chemical Engineering Monographs. Vol. 15. *Toluene the Xylenes and their Industrial Derivatives* (1982)
FPA Information Sheets on Hazardous Materials. H76. Xylene.
NIOSH Criteria for a Recommended Standard. Occupational Exposure to Xylene. (NIOSH Doc. No. 75-168,1975)
Canadian Safety Council *Occupational Safety and Health Data Sheets. No. F- 18: Xylene Dangerous Prop. Ind. Mater. Rep. Nov/Dec 1986,3-11*

Solvents in General Use

| Name | Type* (S, LS, D) | B. Pt. (°C) | Specific Gravity | Rate of Evaporation (Ether = 1) | Flash Point (°C) closed cup |
|----------------------------|------------------------|----------------|---------------------|---------------------------------------|-----------------------------------|
| Esters | | | | | |
| Ethyl acetate | S | 77.1 | 0.907 | 2.9 | -4 |
| Isopropyl acetate | S | 88.8 | 0.930 | 5.0 | 8 |
| n-Propyl acetate | S | 101.6 | 0.896 | 6.1 | 14 |
| n-Butyl acetate | S | 126.5 | 0.883 | 11.0 | 23 |
| n-Amyl acetate | S | 140.0 | 0.877 | 13.0 | 32 |
| Alcohols | | | | | |
| Methyl alcohol | LS | 64.7 | 0.796 | 6.3 | 12 |
| Ethyl alcohol | LS | 78.3 | 0.794 | 8.3 | 14 |
| n-Propyl alcohol | LS | 97.1 | 0.805 | 17.0 | 23 |
| Iso-propyl alcohol | LS | 82.5 | 0.790 | 10.5 | 12 |
| n-Butyl alcohol | LS | 116.0 | 0.813 | 33.0 | 33 |
| Di-acetone alcohol | S | 165.0 | 0.938 | 147.0 | 40 |
| Ketones | | | | | |
| Acetone | S | 56.3 | 0.791 | 2.0 | -17 |
| Methyl ethyl ketone | S | 79.6 | 0.805 | 4.1 | -7 |
| Methyl isobutyl ketone | S | 116.0 | 0.802 | 10.0 | 14 |
| Cyclohexanone | S | 154.0 | 0.950 | 40.0 | 47 |
| Di-isobutyl ketone | S | 168.0 | 0.809 | - | 48 |
| Glycol Ethers | | | | | |
| 2-Ethoxyethanol (1) | S | 135.0 | 0.931 | 43.0 | 40 |
| 2-Butoxyethanol (2) | S | 171.0 | 0.902 | 163.0 | 60 |
| 2-Ethoxyethyl acetate (3) | S | 156.0 | 0.972 | 52.0 | 51 |
| 2-Butoxyethyl acetate (4) | S | 188.0 | 0.944 | 190.0 | 74 |
| 1-Methoxy-2-Propanol | S | 120.0 | 0.930 | 22.0 | 35 |
| 1-Methoxy-2-Propyl acetate | S | 146.0 | 0.968 | 46.0 | 50 |
| Hydrocarbons | | | | | |
| Toluene (Toluol) | D | 110.0 | 0.864 | 6.1 | 7 |
| Xylene (Xylol) | D | 140.0 | 0.862 | 13.5 | 24 |

(1) Also known as Oxitol, Ethyl glycol, Ethylene glycol monoethyl ether

(2) Also known as Butyl Oxitol, Ethylene glycol monocetyl ether, Butyl glycol

(3) Also known as Oxitol acetate, Ethyl glycol acetate, Ethylene glycol monoethyl ether acetate

(4) Also known as Butyl glycol acetate, Ethylene glycol monobutyl ether acetate

Type* S = True solvent for nitrocellulose
 LS = Latent solvent for nitrocellulose
 D = Diluent solvent for nitrocellulose



Appendices

| | |
|---|---|
| <i>I</i> Supporting Documents for this Package | 3 |
| <i>II</i> List of Training Resource Packages available from UNEP IE | 5 |
| <i>III</i> About UNEP Industry and Environment | 7 |

Appendix I

Supporting Documents for this Package

During trials, the following documents were shown to be of great use in supporting the use of this package. They form an integral part of the package.

Audit and Reduction Manual for Industrial Emissions and Wastes [1991]
UNEP / UNIDO.

Tanneries and the Environment [1991] UNEP / UNIDO.

Process Guidance Notes on Leather Finishing [1992] UK DOE.

Appendix II

List of Training Resource Packages available from UNEP IE

The following training resource packages have been developed by UNEP IE. They all use interactive training methodologies to explain the subject, and are aimed at educators who, although technically skilled, may not have specialized knowledge in this particular area. The packages are available from UNEP IE.

Some trainers' packages are still under development, and users are encouraged to assist UNEP to bring these to a final stage of publication.

Due to the cost of printing of the packages (between 100 and 400 pages), the completed documents are offered for sale to most users. However, a limited number of draft packages are free of charge to users prepared to contribute to their further development through review, field testing and adding material. Assistance with translation would also be welcome.

Cleaner Production: a Training Resource Package [1996] First Edition. Contains background reading, transparencies, bibliography, and work exercises. 110 pages. Price \$120 (English, Spanish). This package can be used with the workbooks below.

Trainer's Workbook on Cleaner Production in Leather Tanning [1996] First Edition. Contains background reading, case studies, work exercises and answers. 120 pages. Price \$120.

Trainer's Workbook on Cleaner Production in the Brewing Industry [1996] First Edition. Contains background reading, case studies, work exercises and answers. 75 pages. Price \$100.

Trainer's Workbook on Cleaner Production in Textile Wet Processing [August 1995] First Edition. Contains background reading, case studies, work exercises, answers, references. 140 pages. Price \$120.

Management of Industrial Accident Prevention and Preparedness: a Training Resource Package [1996] First Edition. Contains background reading, case studies and work

exercises. 110 pages. Price \$120. This package also helps to explain the APELL programme.

Risk Management of Contaminated Industrial Land: a Training Resource Package [1996] First Edition. Contains background reading, case studies and work exercises. 110 pages. Price \$120. English, Spanish.

Hazardous Waste, Policies and Strategies: a Training Manual [December 1991] TR10. Contains background reading, case studies, work exercises, reference tables and bibliography. 250 pages. Price \$120. English, French, Spanish.

Landfill of Hazardous Industrial Wastes: a Training Resource Package [March 1994] TR17. Contains background reading, case studies, work exercises, reference tables and bibliography. 315 pages. Price \$120.

Environmental and Technological Issues related to Lead-Acid Battery Recycling: Trainers Workbook [1996] First Edition. Contains background reading, transparencies, bibliography and work exercises. 130 pages. Price \$120.

Environmental Management of Mining Sites: a Training Manual [1995] UNEP/DDSMS.
Contains background reading, transparencies, case studies, work exercises and answers.
200 pages. Price \$160.

Environmental Management Systems: Training Resource Kit [1995] UNEP/ICC/FIDIC.
Contains background reading, transparencies, case studies, work exercises, bibliography.
492 pages. Price \$190.

Aerosol Conversion Technology Handbook [1994]
Price FF225/US\$45 for developed countries.

Training Manual on Chillers and Refrigerant Management [1994] Price FF425/US\$85 for developed countries.

Training Manual on Good Practices in Refrigeration [1994] Price FF400/US\$80 for developed countries.

Environmental Impact Assessment: a training resource manual [1996] Preliminary version.
Available from UNEP Environment and Economics Department, UNEP, Nairobi.

Enquiries UNEP IE

Tour Mirabeau
39-43 quai André Citroën
75739 Paris Cedex 15
France

Tel 33 (1) 44 37 14 50

Fax 33 (1) 44 37 14 74

Email unepie@unep.fr

<http://www.unepie.org/home.html>

Appendix III

About UNEP Industry and Environment

Industry and Environment was established by UNEP in 1975 to bring industry and government together to promote environmentally sound industrial development.

UNEP IE is located in Paris and its goals are to:

- 1 encourage the incorporation of environmental criteria in industrial and development plans;
- 2 facilitate the implementation of procedures and principles for the protection of the environment;
- 3 promote the use of safe and clean technologies;
- 4 stimulate the exchange of information and experience throughout the world.

UNEP IE provides access to practical information and develops co-operative on-site action and information exchange backed by regular follow-up and assessment. To promote

the transfer of information and the sharing of knowledge and experience, UNEP IE has developed three complementary tools:

- technical reviews and guidelines;
- *Industry and Environment*: a quarterly review;
- a technical query-response service.

In keeping with its emphasis on technical cooperation, UNEP IE facilitates technology transfer and the implementation of practices to safeguard the environment through promoting awareness and interaction, training and diagnostic studies.

Some relevant UNEP IE publications

Refer to Appendix II for trainers' packages. For complete list, refer to publications catalogue.

Industry and Environment [quarterly] deals with issues relevant to industrial development, such as auditing, waste management, industry-specific problems, and environmental news.

Government Strategies and Policies for Cleaner Production [1994] 32pp.

Cleaner Production Worldwide Vol. I and II [1995] 48pp.

Life Cycle Assessment: what it is and how to do it [1996] 92pp.

Audit and Reduction of Industrial Emissions and Wastes: Technical Report No. 7 [1991] UNEP/UNIDO. 127pp.

Monitoring of Industrial Emissions and Wastes: Technical Report No. 27 [1996] UNEP/UNIDO. 188pp.

Energy, Efficiency and Climate Change [1991] UNEP/IPIECA. 95pp.

Hazard Identification and Evaluation in a Local Community: Technical Report No. 12 [1992] 86pp.

Health Aspects of Chemical Accidents: guidance on chemical accident awareness, preparedness and response for health professionals and emergency responders Technical Report No. 19 [1994] A joint IPCS/OECD/UNEP/WHO publication: OECD Environment Monograph No. 81. 47pp.

Environmental Aspects of Industrial Wood Preservation: a technical guide Technical Report No. 20 [1994] 105pp.

The Textile Industry and the Environment Technical Report No. 16 [1994] 120pp.

Environmental Management in the Brewing Industry Technical Report No. 33 [1995] 120pps.
Storage of Hazardous Materials Technical Report No. 3 [1990]
Companies Organization and Public Communication on Environmental Issues Technical Report No. 6 [1991] 130pp.

Company Environmental Reporting Technical Report No. 24 [1994] 118pp.
From Regulations to Industry Compliance: Building Institutional Capabilities Technical Report No. 11 [1992] 62pp.

Evaluation Form

Cleaner Production in Leather Tanning

As part of the continuing review of this trainers package, we would appreciate your cooperation in answering the following questions. Please return the completed evaluation form to:

UNEP IE, Tour Mirabeau, 39-43 quai André Citroën, 75739 Paris Cedex 15, France
Fax 33 (1) 44 37 14 74.

- 1** Do you have any suggestions for improvement of the trainers package? How could we improve its readability, contents, practical use, and so on?

- 2** How was the package useful in preparing your own training activity?

- 3** Did the background information provide you with enough information? What was missing?

continued ...

4 What resource information was useful to you? What else should be included?

5 What are your experiences with the exercises? What worked, and what didn't?

6 Do you have training material which could be incorporated into this workbook?

7 What additional topics related to cleaner production would you want to be included in the final version of this workbook?

*Thank you for taking the time to complete this evaluation form. Please return the completed form to
UNEP IE, Tour Mirabeau, 39-43 quai André Citroën, 75739 Paris Cedex 15, France.*