

MARC: Monitoring and Assessment Research Centre

GEMS: Global Environmental Monitoring System



MARC REPORT NUMBER 15

KINETIC AND EXPOSURE COMMITMENT ANALYSES OF LEAD BEHAVIOUR IN A BIOSPHERE RESERVE

Technical Report

Prepared by:
MONITORING AND ASSESSMENT RESEARCH CENTRE
Chelsea College, University of London

With the support of:
UNITED NATIONS ENVIRONMENT PROGRAMME and
THE ROCKEFELLER FOUNDATION

The Monitoring and Assessment Research Centre (MARC), Chelsea College, University of London, became operational on 1 July 1975.

The broad objective of the Centre is to develop methods which will assist in the understanding, definition, evaluation and solution of major environmental problems of global, regional and national concern. Increasing international awareness of these problems, such as chemical pollution, depletion of soil, forest-cover and other important natural resources as well as the spread of endemic diseases, has emphasized the need for such an approach. In this way the Centre offers scientific support to the development of environmental monitoring systems and in particular to the Global Environmental Monitoring System [GEMS] of the United Nations Environment Programme.

The Centre's work is funded by the United Nations Environment Programme and The Rockefeller Foundation.

MARC PUBLICATIONS

MARC GENERAL REPORTS

MARC General Reports are intended as synoptic reviews of environmental topics relevant to monitoring. Each is written by a specialist in the field, keeping a sense of perspective across the whole breadth of the subject. Their main purpose is to be usable by those environmental scientists and managers who are not expert in the topic being covered but who need to obtain a broader, multidisciplinary understanding of monitoring and assessment problems.

MARC TECHNICAL REPORTS

MARC Technical Reports are accounts of environmental research or workshops undertaken or commissioned by MARC. Their main objective is to advance or propagate knowledge in our understanding of the environment and provide useful data and methods of approach for those who are involved in monitoring.

MARC RESEARCH MEMORANDA

MARC Research Memoranda are short informal reports related to MARC'S ongoing work programme. They may include ideas, data and bibliographical material useful to monitoring. Their main purpose is to act as a forum for wider discussion, aiding the clarification and solution of ongoing problems. Where this process proves successful, the Memorandum may be subsequently rewritten to appear as a Technical Report.

ISBN 0 905918 14 2

© MARC, Chelsea College

Kinetic and exposure commitment analyses of lead behaviour in a biosphere reserve

by G. B. Wiersma*

A Technical Report (1979)



Prepared by :
Monitoring and Assessment Research Centre
Chelsea College, University of London

With the support of :
United Nations Environment Programme and
The Rockefeller Foundation

*Present address :
Exposure Assessment Research Division, United States Environmental
Protection Agency, Las Vegas, Nevada 89114

ABSTRACT

Monitoring data acquired as part of a field project to develop a pollutant monitoring system for biosphere reserves are analysed. The field study took place in the autumn of 1977 and spring of 1978 in the Great Smoky Mountains National Park, a designated biosphere reserve site in the U.S.A. A multi-media integrated sampling programme was carried out with a variety of samples collected, including soil, litter, vegetation, water and air. In this report, a kinetic model of this forest ecosystem is developed. Values for compartment sizes and rate constants are determined from the literature. Inputs to the system are from measured values. The model results show good agreement with the measured field results. The steady-state concentrations are used to estimate the transfer coefficients for the exposure commitment analysis. The use of transfer coefficients to compute contributions to steady-state concentrations or to determine exposure commitments is illustrated. It is shown that the exposure commitment method is a useful means of analysing an environmental system and of contributing to the design of monitoring programmes.

CONTENTS

	Page
1.0 Introduction	1
2.0 Monitoring programme in the Great Smoky Mountains Biosphere Reserve	1
2.1 Background	1
2.2 Biosphere reserves and global monitoring	3
2.3 Sampling in the Great Smoky Mountains Biosphere Reserve	4
2.4 Sample analyses	9
3.0 Kinetic model analysis	10
3.1 Model for lead transport in the forest ecosystem	10
3.2 Dynamic equations and steady state solutions	10
3.3 Estimation of model parameters	13
3.4 Comparison of calculated results with field data	20
4.0 Exposure commitment analysis	23
4.1 Introduction and basic relationships	23
4.2 Expressions for lead concentrations in the forest ecosystem	26
4.3 Evaluation of transfer coefficients	29
4.4 Evaluation of compartment concentrations or exposure commitments	30
5.0 Conclusions	36

1.0 Introduction

The detailed analysis of an environmental system is a prerequisite to efficient monitoring design. Such analysis includes the sampling scheme, field measurements, pathway analysis and exposure response. The exposure commitment method rationally ties these aspects together, allowing one to look at the system as a whole rather than at the separate parts.

To date, the exposure commitment approach has been developed and applied to globally dispersed pollutants. Estimates of parameter values have come from measurements at various diverse but representative locations. In this paper, the method is applied to a specific monitoring system development programme in a restricted locality using lead as the pollutant of interest. The area is the Great Smoky Mountains National Park in the United States. The monitoring system development programme was aimed at designing an effective and cost-efficient pollutant monitoring programme for biosphere reserve sites as part of the Man and the Biosphere programme of UNESCO.

In this paper are described first, the field project conducted in the Great Smoky Mountains National Park; second, the development of the model and estimation of required parameters; third, a comparison of the estimates of environmental levels calculated by use of the model with field measurements; and, finally, a discussion on how the model can be used for analysis of data and design of a monitoring system.

2.0 Monitoring programme in the Great Smoky Mountains Biosphere Reserve

2.1 Background

Man's impact on the environment has been far-reaching and at times catastrophic. Today, many pollution problems are recognized as truly global in nature; they transcend geographical and political boundaries.

Elgmork, Hagen and Langeland (1973) reported that snow in Norway contained several pollutants. They found levels of lead up to $98 \mu\text{g } \ell^{-1}$, sulphur levels of $8.5 \text{ mg } \ell^{-1}$ and pH as low as 3.25. The study areas were too remote to be polluted to this extent from local sources, and the limited industry and automobile traffic in Norway could not possibly be responsible for the contaminated snow. They concluded that it resulted from contaminated air masses being brought in by low-pressure systems from the great industrial and urban areas of western and central Europe. Another study by Johnson, Reynolds and Likens (1972) showed that streams in New England were acidified

primarily through washout of sulphur compounds during rain. Most of this sulphur originated from the combustion of fossil fuels in large industrial centres of the eastern and central United States. Schlesinger, Reiner and Knupman (1974) reported that lead, cadmium and mercury were present in precipitation on Mt Moosilauke in New Hampshire. They determined that pollutants were carried by low-pressure air systems coming from the highly populated and industrialized areas of the central and mid-Atlantic regions of the United States and converging on the northern New England states.

Lazarus, Lorange and Lodge (1970) reported that increased values for lead, zinc, copper, iron, nickel and manganese were found in rain water collected in a nationwide precipitation network. Human activity was the primary source of these elements in the rain water. The highest overall concentrations were in the north-eastern United States. A significant statistical correlation existed between the lead concentration at each precipitation sampling station and the quantity of gasoline sold in the vicinity of each of the collection points.

Chow and Earl (1970) studied lead aerosols in the vicinity of San Diego. They stated that only a small fraction of the lead aerosols (based on number, not mass) is deposited near the source of emission. The majority are transported by major air currents and spread throughout the world. Hirao and Patterson (1974) studied lead levels in the Thompson Canyon, a remote site on the High Sierra Crest. According to their data, the 14 km² watershed received 16 kg of deposited lead a year. It was further determined that 97 per cent of this lead was from anthropogenic sources. They stated:

"These findings show that a widespread assumption that lead pollution is mainly confined to urban complexes and is essentially absent in open country, is improbable . . ."

Other elements have been shown to be transported on a global scale. Weiss, Koide and Goldberg (1971) sampled the Greenland ice cap and presented data for mercury levels that indicate a possible build-up of mercury in the ice sheet in recent times. For example, in samples representing deposition prior to 1946, the mean mercury concentration was $60 \pm 17 \text{ ng kg}^{-1}$ of water. The mean mercury concentration for samples representing time from 1952 to 1965 had a mean concentration of $125 \pm 52 \text{ ng kg}^{-1}$ of water.

Zoller, Gladney and Duce (1974) analysed atmospheric particulate material at the South Pole for 22 elements. Antimony, lead, selenium and bromine were all highly enriched over what could be expected

from earth crustal values. They postulated that these compounds originated from high-temperature combustion sources, either natural volcanoes or man-made fossil fuel burning.

Global transport has also been confirmed for other pollutants such as DDT. For example, Anas and Wilson (1970) reported that nursing seal pups collected on the Pribilof Islands in 1969 contained DDT and its isomers in both the pups' fat tissue and in the mothers' milk.

2.2 Biosphere reserves and global monitoring

Concern over the widespread global contamination from man's activities has been one of the driving forces behind the attempt to establish a global monitoring network at biosphere reserve sites. Study of Critical Environmental Problems (SCEP) report (Anon. 1970a) stated:

"Over the past few years, the concept of the earth as a 'space-ship' has provided many people with an awareness of the finite resources and the complex natural relationships on which man depends for his survival. These realizations have been accompanied by concerns about the impacts that man's activities are having on the global environment. Some concerned individuals, including well-known scientists, have warned of both imminent and potential global environmental catastrophes."

A variety of organizations and committees – including the International Task Force of the Global Network for Environmental Monitoring; the Global Monitoring Task Force of SCOPE; the Man and Biosphere Expert Panel on Pollution; the Study of Critical Environmental Problems (SCEP); Task Force II, Committee on International Environmental Monitoring and Assessment – have called for the formation of a global monitoring network. The requirements for and value of biosphere reserves have been described in general in a variety of reports, including the Report of the Ad Hoc Task Force on GNEM (Anon. 1970b) and the SCOPE Report 3 (Munn 1973).

The United Nations Conference on the Human Environment held in Stockholm in June 1972 recommended the establishment of the United Nations Environment Programme. It also recommended the establishment of EARTHWATCH, a project within UNEP which has a four-pronged programme including monitoring, research, evaluation and information exchange. To achieve part of the objective of EARTHWATCH the Global Environmental Monitoring System (GEMS) was

established. To contribute to the GEMS programme it was recommended that biosphere reserves be established within the framework of the Man and the Biosphere Programme (MAB) (Anon. 1974). The report "Man's Impact on the Global Environment" (Anon. 1970a) recommended similar entities, calling them ecological baseline stations in remote areas or biosphere reserves.

Biosphere reserves may be defined as undisturbed and protected natural background areas of the earth, where life processes occur with minimal human interference.

Reasons for establishing biosphere reserves are :

1. They will provide a permanent record of the relatively undisturbed state of the environment.
2. They will insure the availability of undisturbed areas from which background data on pollution levels can be obtained.
3. They will give an indication of increasing levels of global pollution.
4. They will serve as repositories for natural sources of genetic pools of animal and plant species.

Franklin (1974, 1977) lists several kinds of research and monitoring activities which the reserves could be used for. These include :

1. Long-term baseline studies of environmental and biological features.
2. Research to help develop management policies for the reserves.
3. Experimental or manipulative research (outside strictly preserved areas) particularly on the ecological effects of human activities.
4. Environmental monitoring, including use as part of the GEMS system.
5. Study sites for various MAB research projects.

2.3 Sampling in the Great Smoky Mountains Biosphere Reserve

As part of a research effort to develop a recommended monitoring system for biosphere reserves, selected areas within the Great Smoky Mountains National Park were sampled in the autumn of 1977 and spring of 1978. A generalized approach for such a monitoring system was developed by Wiersma, Brown and Crockett (1978a). Through the co-operation of the U.S. Park Service and the U.S. Environmental Protection Agency, the concepts were tested on a preliminary basis in the Great Smoky Mountains National Park. A detailed description of the autumn sampling and results are given in Wiersma, Brown and Crockett (1978b) and Wiersma *et al.* (1979a).

During the autumn 1977, four locations within the park were sampled

with the help of park personnel (Figure 1). Soil, vegetation, unincorporated litter and water samples were collected at each of these sites. Litter means the unincorporated organic debris and the underlying fermentation layer. Two sites were located on the north slopes of the Smoky Mountains, one site was located on top of the ridge, and the fourth site was located at a lower elevation on the south side of the mountains.

It was originally planned to collect samples from each site at nine points on a 3 x 3 grid, with approximately 200 metres between grid points. Because of the thick understorey and steep slopes, samples had to be taken along the trail. The nine sampling points were laid out along trails at 200 metre intervals. Each sampling point was 40 metres off the trail.

Unincorporated litter was sampled at 10 locations evenly spaced around a 10 metre diameter circle at each sampling site. A one-litre sample was collected at each location. The 10 one-litre samples were combined and thoroughly mixed. A half-litre aliquot was retained in a polyethylene container for analysis. At each of these 10 locations a five-centimetre deep soil sample was collected after the unincorporated litter layer was removed. These 10 soil samples were thoroughly mixed and a half-litre aliquot was retained. At each sampling site, two species of plants were sampled. In general, one species was a perennial shrub and efforts were made to collect the current year's growth; the other species was an annual.

One-litre water samples were collected at each site and at 11 other locations around the park, chosen with the aid of park personnel to be representative of the drainage patterns in the Smoky Mountains. At each sampling site a one-litre sample was collected in a Teflon bottle and immediately acidified with nitric acid. Each one-litre sample was analysed separately for trace elements.

Air samples were collected in the autumn sampling period but analytical and sampling problems precluded the usefulness of the data.

The spring sampling was more intensive than the autumn sampling in terms of numbers of sites, species of vegetation collected and air sampling. The techniques used for collecting soil, litter, water and vegetation were essentially the same as in the autumn sampling with the exception that forest litter was separated in the field into unincorporated litter and fermentation layer and analysed separately. Basically the same forest types were chosen but the number of sites was expanded from four to ten (Figure 1). The number of species

Figure 1. Sampling Locations Great Smoky Mountains National Park

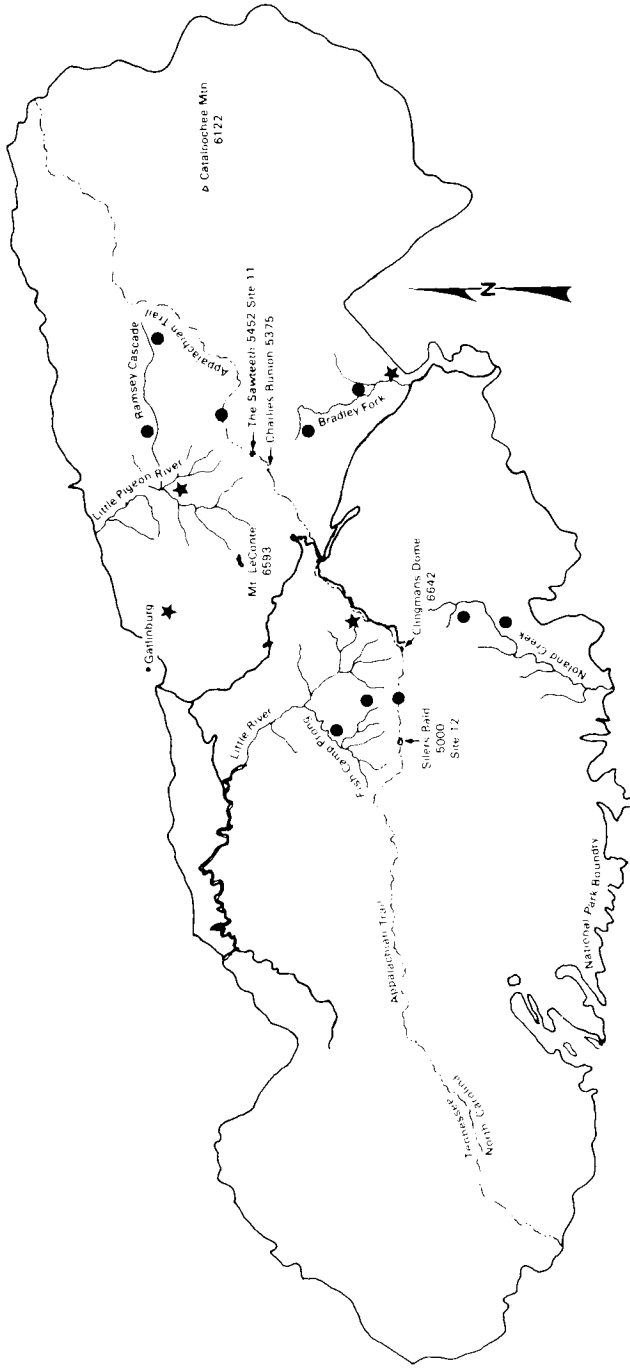

- ★ Sampled Autumn, 1977.
- Sampled Spring, 1978.

of vegetation collected at each site was expanded from two to five.

The forest types sampled in the autumn and spring were essentially the same three categories :

Cove-Hardwood Forest

Tulip Poplar Forest

Spruce-Fir Forest

These have been described and characterized in detail by Whitaker (1956).

Special efforts were made to collect air particulate samples in the remote areas of the Park. Two remote sites were established in the Park. These were the Silers Bald site (site 12) and Sawteeth site (site 11) (Figure 1). Criteria for the selection of these sites were that they should be located

- at least 8 kilometres from the nearest road with any automobile traffic
- at as high an elevation as possible
- in a cleared area with a diameter at least five times the height of the surrounding forest.

The two sites chosen met these criteria.

In addition, eight other air monitoring sites were established. However, these were co-ordinated with vegetation and soil sampling and did not meet the requirements mentioned above. All were located under forest canopy and a minimum of three kilometres from a road where automobile traffic was permitted; most were considerably further away, up to 10 kilometres.

Millipore filters (0.45 μm) were purchased already mounted and sealed in plastic holders. The plastic filter holders were not opened until the air monitoring system was ready to be turned on in the field. Millipore filters were set up in groups of four at each site. In general this allowed for the analysis of three filters by three independent techniques with the fourth reserved for archives.

Unopened filters that went into the field were submitted for analysis along with the opened filters.

Table 1 is a summary of the air sampling sites, flow rates, length of time sampled, volume of air sampled, type of analyses and site description.

An air sampling system was specifically designed to meet the needs of this project. Local power sources were not available where the air samplers were to be operated. The use of gasoline-powered generators was obviously ruled out because of contamination problems and propane gas generators were not used because of logistics. Therefore,

Table 1. Summary of air sampling sites in the Great Smoky Mountains National Park

Site No.	Name	Site description	Number of hours operated	Average flow rate (litre per minute)	Total air sampled (m ³)	Types of analyses x-ray SEM AA
12	Silers Bald	Open, remote site 8 kilometres from nearest road	188.5	1.0	11.3	X X X
11	Sawteeth	Open, remote site 8 kilometres from nearest road	168.0	1.0	10.1	X X X
1	Fish Camp Prong	Logged hardwood forest—north slope	69.5	1.0	4.2	X X X
3	Low altitude Ramsey Cascade	Unlogged hardwood forest—north slope	167.0	1.0	10.0	X X X
4	High altitude Ramsey Cascade	Unlogged hardwood forest—north slope	162.5	0.9	8.8	X X X
5	Low altitude Noland Creek	Logged hardwood forest—south slope	142.5	1.0	8.6	X X X
6	High altitude Noland Creek	Unlogged hardwood forest—south slope	144.5	1.0	8.7	X X X
8	High altitude Richland Mt.	Unlogged hardwood forest—south slope	142.0	1.0	8.5	X X X
—	Las Vegas, NV	Urban environment	120.0	1.0	7.2	X X X

a portable, battery-operated system was needed. This system, described in detail by Brown, Wiersma and Frank (1979), consists of a Dupont air pump (Model P-4000A) operated by a specially designed battery pack using Gates rechargeable sealed acid batteries. Air flow was controlled by Dwyer rotameters connected to the Millipore filters and the Dupont pump by amber latex laboratory tubing. As can be seen from Table 1, these pumps operated continuously for up to 188 hours. Except for one site, flow rates held constant throughout the entire sampling time. Of the 10 stations established, only two failed during the sampling period.

2.4 Sample analyses

The vegetation and litter samples were analysed on contract by the University of California's (UCLA) Laboratory of Nuclear Medicine and Radiation Biology. The technique used was spark-source emission spectrometry previously described by Anderson *et al.* (1975). Water samples were analysed by inductively coupled plasma emission spectrometry (ICPES) and also by spark-source mass spectrometry (SSMS) by the U.S. Environmental Protection Agency's Environmental Research Laboratory in Athens, Georgia. The ICPES is capable of rapidly giving an accurate determination of a specific group of 26 elements (including lead). The SSMS was used to give a survey analysis of the entire spectrum of elements (except for gases). In addition, the SSMS is more sensitive for certain elements than the ICPES system. One of these elements is lead. The detection limit for lead was $0.05 \text{ mg } \ell^{-1}$ using ICPES and $0.001 \text{ mg } \ell^{-1}$ using SSMS.

Soil samples were acid extracted and analysed by atomic absorption spectrophotometry. Twenty-five millilitres (ml) of concentrated nitric acid were added to 10 grams of oven-dried (60°C) soil in a 125 ml Erlenmeyer flask. The samples were boiled under reflux for 17 hours. The soil was separated from the supernatant by centrifuge or filtration and washed three times with distilled de-ionized water. The supernatant and washes were combined in a volumetric flask and diluted to 100 ml. Sample extracts, distilled water blanks, acid blanks, standards and spike solutions were analysed in duplicate for lead.

The air filters were analysed by three independent techniques: atomic absorption (AA) spectrophotometry using "clean" laboratory facilities; x-ray fluorescence techniques; and scanning electron microscopy (SEM) techniques for particle characterization. The x-ray fluorescence technique used was as described by Jaklevic, Goulding,

Jarrett and Meng (1973) and Jaklevic, Loo and Goulding (1976). Scanning electron microscope analyses were used to determine particle size and composition. Atomic absorption analyses were done in the clean laboratory facilities at Carnegie-Mellon University.

The results for lead from x-ray fluorescence agreed very well with the results from the atomic absorption method. Detailed results including particle analyses are given by Wiersma, Frank, Brown and Davidson (1979b).

3.0 Kinetic model analysis

The samples from the Great Smoky Mountains National Park were analysed for several trace metals. Lead was chosen for model development and transport analysis because it is a pollutant of recognized global concern and because of the extensive data base available to fill in missing information.

3.1 Model for lead transport in the forest ecosystem

The model for lead transport in the Great Smoky Mountains National Park is shown schematically in Figure 2. This model and subsequent discussion are based on the assumption of steady-state conditions and that the transfers of pollutants between compartments follow first order kinetics. The model restricts itself to the cove-hardwood/tulip-poplar forest types and does not consider the conifer forest type. The rate constant (k_i) defines the fractional transfer of lead per unit time. Because of the peculiar nature of certain forest processes, particularly leaf fall, the values of the rate constants are estimates of transfer in one year.

3.2 Dynamic equations and steady state solutions

The differential equations describing the transfer of lead in this model are as follows:

$$\text{Vegetation} \quad \frac{d Q_A}{dt} = q_2 + k_4 Q_D - k_1 Q_A - k_2 Q_A \quad (1)$$

$$\text{Forest litter} \quad \frac{d Q_B}{dt} = q_1 + k_1 Q_A + k_3 Q_E - k_5 Q_B \quad (2)$$

$$\text{Surface water} \quad \frac{d Q_C}{dt} = q_3 + k_7 Q_F + k_9 Q_D - k_8 Q_C \quad (3)$$

Figure 2. Schematic diagram of movement and distribution of lead in the Great Smoky Mountains National Park

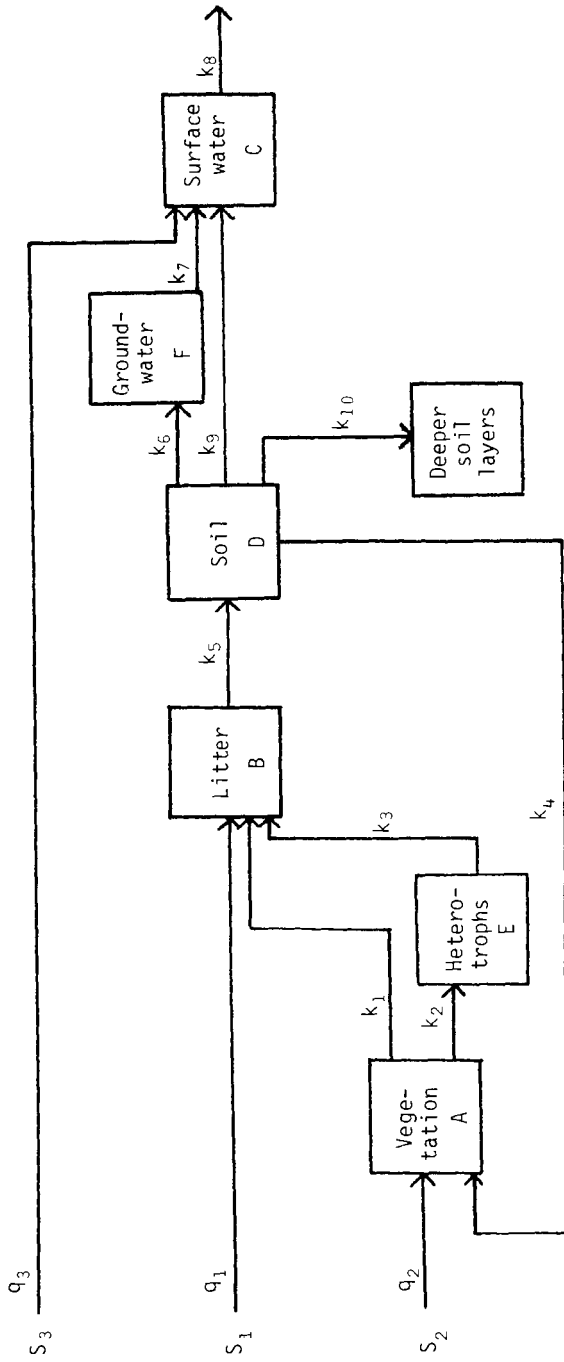

$$\text{Soil} \quad \frac{d Q_D}{dt} = k_5 Q_B - k_4 Q_D - k_9 Q_D - k_6 Q_D - k_{10} Q_D \quad (4)$$

$$\text{Heterotrophs} \quad \frac{d Q_E}{dt} = k_2 Q_A - k_3 Q_E \quad (5)$$

$$\text{Ground water} \quad \frac{d Q_F}{dt} = k_6 Q_D - k_7 Q_F \quad (6)$$

Under steady-state conditions the rate of change of the amount of lead in any compartment is zero so that the left-hand side of equations 1-6 above is zero. The equations can now be solved to obtain the equilibrium amount in each compartment. Dividing this equilibrium amount of lead by the total mass of the specific compartment, the steady-state concentration of lead (C_i^*) in each compartment is obtained.

$$\text{Vegetation} \quad C_A^* = \frac{q_2 (k_9 + k_6 + k_{10}) + k_4 (q_1 + q_2)}{M_A (k_1 + k_2) (k_9 + k_6 + k_{10})} \quad (7)$$

$$\text{Forest litter} \quad C_B^* = \frac{(k_4 + k_9 + k_6 + k_{10}) (q_1 + q_2)}{k_5 M_B (k_9 + k_6 + k_{10})} \quad (8)$$

$$\text{Surface water} \quad C_C^* = \frac{q_3 (k_9 + k_6 + k_{10}) + (q_1 + q_2) (k_6 + k_9)}{k_8 M_C (k_9 + k_6 + k_{10})} \quad (9)$$

$$\text{Soil} \quad C_D^* = \frac{q_1 + q_2}{M_D (k_9 + k_6 + k_{10})} \quad (10)$$

$$\text{Heterotrophs } C_E^* = \frac{q_2 k_2 (k_9 + k_6 + k_{10}) + k_4 k_2 (q_1 + q_2)}{k_3 M_E (k_1 + k_2) (k_9 + k_6 + k_{10})} \quad (11)$$

$$\text{Ground water } C_F^* = \frac{k_6 (q_1 + q_2)}{k_7 M_F (k_9 + k_6 + k_{10})} \quad (12)$$

Symbols used are defined as follows :

C_i^* = Steady-state concentration of lead in compartment i

M_i = Mass of compartment i

Q_i = Quantity of lead in compartment i

q_1 = Amount of lead deposited on ground surface per hectare per year

q_2 = Amount of lead deposited on overstorey leaf surface per hectare per year

q_3 = Amount of lead deposited on open surface water per hectare per year

3.3 Estimation of model parameters

3.3.1 Input rates

The amounts of lead deposited were derived from measured air concentrations during the spring 1978 sampling in the Great Smoky Mountains National Park (see section 2.0).

Measurements were made under the canopy and outside the canopy. All canopy measurements were in the hardwood forest (cove hardwood/tulip poplar). No significant differences were determined between lead concentration in air outside the canopy and under the canopy. All values were thus combined to determine an average air concentration which equalled 73 ng m^{-3} .

Rainwater was measured during the spring 1978 sampling period. However, no lead was found in the rain water at our limits of detection. Therefore, the deposition due to lead in rain water could not be estimated. Since the air samplers were operated during both wet and dry periods, the measured air concentration for lead will, for the purposes of this paper, be considered to be an average concentration for wet and dry periods; and total lead input to the system for a year will be calculated using the following relationships :

$$\text{Rate of dry deposition } (\mu\text{g cm}^{-2} \text{ s}^{-1}) = \text{dry deposition velocity} \times \text{concentration in air}$$

This assumption (total lead input calculated from the dry deposition rate and the air concentration for a wet/dry period) is approximate. Cawse (1974) for a remote site in England, estimated the concentration factor ξ for lead to be approximately 100. Assuming that rain occurs 30 per cent of the time with 80 inches of rain a year falling in the Great Smoky Mountains (Shanks 1954), and that during rain no lead is deposited on leaf surface, the total input rate per hectare is $0.33 \text{ kg ha}^{-1} \text{ y}^{-1}$. An alternative estimate using only the average air concentration and the dry deposition rate, making allowances for leaf surface interception, gives a total input of $0.31 \text{ kg per hectare per year}$. The latter estimate, involving fewer assumptions, is reasonable and therefore this estimation procedure is accepted.

To calculate the lead flux to soil, the "dry deposition velocity" (V_d) must be determined. In the Great Smoky Mountains study this was not measured. Literature estimates vary. Cawse (1974) cites several V_d values for lead for seven sites in the United Kingdom. They averaged about 0.4 cm s^{-1} . Cawse and Pierson (1972) stated that V_d is related to particle diameter with a V_d of 0.2 cm s^{-1} associated with particle diameter of $0.5 \mu\text{m}$. Virtually all the particles measured by scanning electron microscopy in the Great Smoky Mountains study were less than $1.0 \mu\text{m}$ in size. The Smoky Mountains are more remote than the seven stations measured by Cawse (1974) and therefore longer transport of lead is involved with potentially smaller particles leading to a slightly smaller V_d estimate. Therefore, based on this information, a V_d of 0.3 cm s^{-1} was taken for the Great Smoky Mountains.

The measured air concentration for lead was combined with the estimated value for V_d , and the rate of lead deposition was calculated for a year and on a per hectare basis. The steady state assumption says that, from year to year at least, the lead input via air is constant. Within limits, this is probably true. For sites which have similar distances from large area sources of lead (for example, 75 to 100 km), measured lead concentrations in air are similar to the Great Smoky Mountains region which is about 80 km south of Knoxville, Tennessee. Chow and Earl (1970) report that lead levels in air at Mount Laguna station at the San Diego State College Observatory about 75 km east of San Diego averaged approximately 50 ng m^{-3} . Moyers, Ranwieler, Hopf and Korte (1977) reported lead levels at a desert site about 100 km south-east of Tucson to be about 67 ng m^{-3} . Cawse (1974) reports the concentration of lead in air from about 56 ng m^{-3} to 93 ng m^{-3} for two sites in the

$$\xi \text{ concentration factor} = \frac{\text{concentration of lead in rain (ng kg}^{-1}\text{)}}{\text{concentration of lead in air (ng kg}^{-1}\text{)}}$$

U.K. considered "clean". It is unlikely that these sites were further than 75 km from a major city. Therefore, it seems reasonable that the measured air concentration in the Great Smoky Mountains is representative of average conditions over a year's time.

Allowance must be made for direct deposition of lead onto surface water. There are virtually no lakes or large bodies of water within the Great Smoky Mountains National Park. Hynes (1970) estimates about 0.1 per cent of land area to be occupied by rivers and streams. This value was used to obtain the estimates of direct lead input to surface water.

Finally, leaf surface area of the overstorey is an effective filter for lead particles. Whitaker (1966) estimated that the upper cove hardwood and tulip poplar forests in the Great Smoky Mountains have an average leaf area index § of 6.8. Assuming the leaves are present from six to seven months during the year, this figure becomes approximately 3.7. Input of lead to leaves is assumed greater than the input to soil by this amount.

The calculated inputs of lead (q_i) to the land, leaf and water surfaces are as follows:

$$q_1 = 0.069 \text{ kg ha}^{-1} \text{ y}^{-1}$$

Estimated input to land surface corrected for that falling on surface water

$$q_2 = 0.26 \text{ kg ha}^{-1} \text{ y}^{-1}$$

Estimated input as a result of leaf area entrapment in the overstorey

$$q_3 = 0.0001 \text{ kg ha}^{-1} \text{ y}^{-1}$$

Estimated input falling directly on surface water

3.3.2 *Compartment sizes*

To use equations 7 through 12, estimates must be made of the appropriate masses or volumes of the compartments. These will be expressed on a unit area basis.

Mass of vegetation (M_A) is essentially the mass of the overstorey vegetation, which gives input to forest litter. Van Hook, Harris and Henderson (1977) estimated the average annual foliage production for an oak-hickory forest in Tennessee to be $4,000 \text{ kg ha}^{-1}$. Roschow (1974) estimated the annual foliage production (including forest floor vegetation) to be $3,500 \text{ kg ha}^{-1}$ for an oak-hickory stand in Missouri, but did not include small and large saplings. An estimate by Johnson and Risser (1974) of the annual foliage input to forest litter was $5,500 \text{ kg ha}^{-1}$ for post oak-black jack oak forest. Gosz, Likens and Bormann (1972) estimated the annual leaf fall for a northern hardwood forest (similar in structure to the cove hardwood forests of the Great Smoky

§ Leaf area index = $\frac{\text{Surface area of leaves}}{\text{Supporting land area}}$

Mountains) to be about $5,700 \text{ kg ha}^{-1}$ with 98 per cent of this total from the overstorey. Bray and Gorham (1964) reported that in a mixed sugar maple stand in Toronto annual production of litter was $4,300 \text{ kg ha}^{-1}$, and an oak hickory-tulip poplar forest in Tennessee produced about $5,400 \text{ kg ha}^{-1} \text{ y}^{-1}$. Reiners (1972) estimated annual input to the litter to be $4,700 \text{ kg ha}^{-1}$.

For the Great Smoky Mountains, Whitaker, Bormann, Likens and Siccama (1974) estimated the net primary production for overstorey leaves and twigs, shrubs and herbs of the cove hardwood forest to be $4,300 \text{ kg ha}^{-1} \text{ y}^{-1}$. For the tulip poplar forest type, the same net primary production was $6,700 \text{ kg ha}^{-1} \text{ y}^{-1}$. Since our sampling in the deciduous forests of the Great Smoky Mountains was split equally between these two forest types, the two estimates were averaged to give an effective compartment size of $5,500 \text{ kg ha}^{-1}$. This figure agrees well with the above reported estimates in the literature and is used in this paper for M_A .

The mass of forest litter (M_B) has also been studied and reported in the literature, unfortunately not for the Great Smoky Mountains. The literature values vary. For an oak-hickory forest, Monk, Child and Nicholson (1970) report $12,000 \text{ kg ha}^{-1}$ including dead branches, and $9,560 \text{ kg ha}^{-1}$ excluding branches. Van Hook, Harris and Henderson (1977) estimated forest litter for an oak-hickory forest to be $23,000 \text{ kg ha}^{-1}$ including branches. Excluding branches, corresponding to litter samples from the Great Smoky Mountains, would give an estimate of $18,300 \text{ kg ha}^{-1}$. For an upland pin oak forest Reiners (1972) estimated litter mass to be $13,000 \text{ kg ha}^{-1}$. For a post oak-black jack oak forest, Johnson and Risser (1974) estimated forest litter mass to be $10,800 \text{ kg ha}^{-1}$. In general, the forests in the Great Smoky Mountains have greater biomass than the types of forests mentioned above.

Monk, Child and Nicholson (1970) report net primary production for an oak-hickory stand equal to $600 \text{ g m}^{-2} \text{ y}^{-1}$. For the Great Smoky Mountains a comparable figure for a climax site is approximately $1,100 \text{ g m}^{-2} \text{ y}^{-1}$. The ratio of these two figures is 1.83. Multiplying by the estimated litter mass reported by Monk, Child and Nicholson (1970) of $9,560 \text{ kg ha}^{-1}$, one obtains an estimate of approximately $17,500 \text{ kg ha}^{-1}$ for litter mass in the Great Smoky Mountains.

The relationship to total biomass on the site is another approach to estimating litter mass. Johnson and Risser (1974) estimated above ground biomass for an oak-hickory stand at $180,500 \text{ kg ha}^{-1}$. Average above ground biomass for cove hardwood forest and tulip poplar forest

reported by Whitaker (1966) is approximately $360,000 \text{ kg ha}^{-1}$, giving a ratio of 1.99. Multiplying by the litter mass estimate of Johnson and Risser (1974) of $10,800 \text{ kg ha}^{-1}$, one obtains a litter mass estimate of $21,500 \text{ kg ha}^{-1}$, which would apply approximately to the Great Smoky Mountains.

Considering the above estimates, a value of $18,500 \text{ kg ha}^{-1}$ has been chosen for an estimate of the litter mass for both the cove hardwood forest and the tulip poplar forest in the Great Smoky Mountains.

Surface water mass (M_C) was estimated from information provided by the U.S. National Park Service§ which indicated an average discharge from the Great Smoky Mountains National Park of $2,000 \text{ ft}^3 \text{ s}^{-1}$, corresponding to a surface water volume of $86.5 \times 10^5 \text{ l ha}^{-1}$.

Soil mass (M_D) was estimated for a layer of soil 5 cm deep, the sampling depth used in the Great Smoky Mountains study, with a density of 1.5 g cm^{-3} . This gives a soil mass of $760,000 \text{ kg ha}^{-1}$.

Mass of heterotrophs (M_E) is uncertain. There is little data available in the literature. It is assumed to be 10 per cent of the net primary production or about 550 kg ha^{-1} .

Ground water mass (M_F) is also difficult to estimate. The assumptions used in this paper are essentially those used by Karubian (1974) in developing a method for predicting ground water pollution. He estimated the ground water velocity at 1 m d^{-1} and assumed the pollutant mixed by dispersive action in the top three metres of the ground water body below the water table. The aquifer porosity was estimated to be 0.33. This then gives $36.1 \times 10^6 \text{ l ha}^{-1}$ for the volume of ground water in the Great Smoky Mountains National Park.

3.3.3 Transfer rate constants (k_i)

The rate constant k_1 (the fractional transfer per year of lead from overhead vegetation to forest floor) was estimated to be 0.85 y^{-1} . Leaves turn over once a year for a deciduous forest. It was estimated that the maximum amount consumed by heterotrophs is no greater than 15 per cent. This amount (0.15) subtracted from total leaf fall (1.0) gives 0.85.

The rate constant k_2 (the fractional transfer per year of lead from vegetation to heterotrophs) is estimated at 0.15 y^{-1} . This is a standard proportion, generally considered the maximum (Kormondy 1969). Under steady-state conditions, all of the autotrophic and heterotrophic mass eventually reaches the litter.

The rate constant k_3 is the fractional amount of lead contained in the heterotrophic compartment that is returned to forest litter per year. Most

§Personal communication from Dr. Gary Larsen, Uplands Field Research Station, Gatlinburg, Tennessee.

heterotrophs (micro-organisms, insects) would die within a year, but not all. Those heterotrophs which are likely to have life spans of a year or more are also likely to have much greater individual mass. Therefore, k_3 was taken to be equal to 0.8 y^{-1} .

The rate constant k_4 is the fractional transfer of lead from soil to plants per year. A great deal of information is available on the subject. Alloway and Davies (1971) studied lead uptake by grass under field conditions and in pot studies. Plants in the field were carefully washed. The rate constant varied from 0.01 to 0.05 y^{-1} . Johnson, McNally and Putwain (1977) grew plants on mine tailings. They found that the rate constant varied from 0.07 to 0.13 y^{-1} . Lead levels in these soils were in the $11,000$ to $42,000 \mu\text{g g}^{-1}$ range. Lagerwerff and Specht (1970) studied plants growing near roadsides. They found rate constants ranging from 0.09 to 0.21 y^{-1} . They used minimal washing of vegetation prior to analysis. This makes discrimination between airborne lead and uptake from soil difficult.

MacLean, Hasted and Finn (1972) added lead chloride to soil with pH of 5.7 and cation exchange capacity of 11.7. They grew oats and alfalfa at three levels of different concentrations (100 , 500 and $1,000 \mu\text{g g}^{-1}$). The rate constants varied between 0.01 to 0.09 y^{-1} except for one of the nine trials. Here the rate constant was 0.36 y^{-1} .

Rabinowitz (1972) determined the difference between lead uptake from soil and air deposition by isotopic ratios of lead. The rate constant for lettuce averaged 0.03 y^{-1} and for oats 0.1 y^{-1} . Based on all of the above, a value of 0.04 y^{-1} is taken for k_4 .

The rate constant k_5 is the fractional amount of lead transferred from forest litter to soil per year. Van Hook, Harris and Henderson (1977) estimated this at about 0.2 y^{-1} . They base this on the assumption of 1:1 correspondence of lead to carbon loss from forest litter to soil. No other adequate data were found; therefore the rate constant of 0.2 y^{-1} is used for k_5 .

The rate constant k_6 is the fractional amount of lead transferred from the soil to the ground water per year. Data are scarce on this phenomenon. However, the ability of lead to move in soil seems to be minimal. Rabinowitz (1972) reported that even a water soluble form of lead (lead nitrate), when added to a soil system, is quickly immobilized. Korte *et al.* (1976) could detect no lead moving through a soil column after lead chloride had been added to the soil. Fuller, Korte, Miebla and Alessi (1976) could detect no lead moving through naturally contaminated soil columns within their detection limit of $0.5 \mu\text{g l}^{-1}$. Tyler

(1976) estimated about 1.8 per cent of the lead in the soil column would be removed after leaching with an amount of water of the order of 200 cm of rain (equivalent to about 80 inches of rain per year) at a pH of 4.2. However, the soil system studied by Tyler was composed of ground-up mor humus from underneath a coniferous forest with a minimum mineral constituent. This is drastically different from the soils in the Great Smoky Mountains. Kee and Bloomfield (1962) determined that about 0.001 of the lead present in a soil column was lost when leached with distilled water and 0.009 was lost when leached with water incubated previously with dead plant material. The actual value is likely to be quite low. Since several investigators could detect no lead moving in a soil column and Kee and Bloomfield (1962) detected minimal amounts, k_6 is estimated at 0.0005 y^{-1} .

The rate constant k_7 is the fractional amount of lead transferred out of the ground water reservoir in a year to surface drainage. This is also difficult to estimate, but if the velocity of one metre per day is used, and the average distance to surface water is assumed to be one kilometre, then k_7 would be about 0.4 y^{-1} .

The rate constant k_8 is the fractional amount of lead lost from streams per year in the Great Smoky Mountains to sinks outside the park. It can be assumed that all lead present in streams will be moved out of the park except that lost by sedimentation. The streams in the Great Smoky Mountains are very fast running and clear and drain heavily forested watersheds. The sediment load is likely to be low. Bormann *et al.* (1974) for a similar watershed in New Hampshire estimated the total amount of particulate lost at $2.5 \text{ t km}^{-2} \text{ y}^{-1}$. Therefore, the proportion lost in sedimentation is likely to be small and the amount carried out by the streams in a year has been estimated as 0.8 of the amount entering.

The rate constant k_9 is the fractional amount of lead lost from soil to surface water per year. Lead can leave the system dissolved in surface run-off and adsorbed to particulates. Thus, both of these must be considered in calculating k_9 . Bormann *et al.* (1974) estimated particulate loss at $2.5 \text{ t km}^{-2} \text{ y}^{-1}$ or $25 \text{ kg ha}^{-1} \text{ y}^{-1}$. Expressed as a proportion of total litter per hectare, this gives 0.001. Expressed as a proportion of the litter plus the upper one centimetre of soil it is 0.0001 y^{-1} . Since surface water transport is very likely to involve litter and surface soil, the last figure seems more reasonable. The solubility of lead in surface water is likely to be similar to the figure estimated for ground water. Therefore, adding this to the particulate estimate gives 0.0006 y^{-1} .

The rate constant k_{10} , the fractional transfer of lead per year from top

soil to deep soil layers, was calculated to be about 0.022 y^{-1} . Van Hook, Harris and Henderson (1977) stated that soil is a major sink for lead. Cartwright, Merry and Tiller (1978) claimed that lead around a smelter accumulated in the top 10 cm of soil. Chow (1970) reported that, for soil collected along roadways, lead accumulates in the upper 10 cm. Rolfe and Jennett (1975) also found the soil to be a major sink for lead. Ward, Reeves and Brooks (1975) calculated the total lead emitted from automobiles along a road in New Zealand since 1930. Of this amount, 58 per cent could be accounted for by lead in the upper 6 cm of soil located along this road.

Movement of lead down through the soil profile is probably small, but greater than the amount moved by water percolation alone. For example, Reichle *et al.* (1973) estimated that earthworms alone could turn over the top 25cm of forest soil in 44 years. This indicates that a value of 0.022 y^{-1} for k_{10} is not unrealistic and may be slightly on the low side.

Input rates and model parameters are summarized in Table 2.

3.4 Comparison of calculated results with field data

Table 3 summarizes the calculated steady-state concentrations obtained using the estimated input rates and parameters as described in Section 3.3 Also listed are the measured concentrations from the Great Smoky Mountains study.

No samples were collected from overstorey vegetation. Understorey vegetation levels of lead were generally low. To get an indication of the validity of the calculated value for overstorey vegetation, comparisons with results for moss samples can be made. Moss has been shown to be an efficient collector of air particulates (Goodman and Roberts 1971) and therefore is presented as a rough comparison for overstorey calculated levels. Moss samples were collected in the spring 1978; none were collected in the autumn of 1977. The range of means is as shown in Table 3. Each mean is composed of approximately 10 samples and 30 analyses.

Lead levels in forest litter were determined from samples collected in the autumn of 1977 which included both the unincorporated litter and fermentation layers ($O_1 + O_2$ layers). The average lead level of $273 \mu\text{g g}^{-1}$ is based on 27 samples from three different hardwood stands of the type described previously. The agreement between calculated and measured concentrations is good.

The calculated concentration of lead in water is 0.002 mg l^{-1} . Two

Table 2 Input rates and parameters for lead transfer in the forest ecosystem

Source input rates per unit surface area

Atmosphere to litter	q_1	0.069	$\text{kg ha}^{-1}\text{y}^{-1}$
Atmosphere to vegetation	q_2	0.26	$\text{kg ha}^{-1}\text{y}^{-1}$
Atmosphere to surface water	q_3	0.0001	$\text{kg ha}^{-1}\text{y}^{-1}$

Sizes of compartments per unit surface area

Vegetation	M_A	5,500	kg ha^{-1}
Litter	M_B	18,500	kg ha^{-1}
Surface water	M_C	8.65×10^6	$\ell \text{ ha}^{-1}$
Soil	M_D	760,000	kg ha^{-1}
Heterotrophs	M_E	550	kg ha^{-1}
Ground water	M_F	36.1×10^6	$\ell \text{ ha}^{-1}$

Transfer rate constants

Vegetation	to	litter	k_1	0.85	y^{-1}
Vegetation	to	heterotrophs	k_2	0.15	y^{-1}
Heterotrophs	to	litter	k_3	0.80	y^{-1}
Soil	to	vegetation	k_4	0.04	y^{-1}
Litter	to	soil	k_5	0.20	y^{-1}
Soil	to	ground water	k_6	0.0005	y^{-1}
Ground water	to	surface water	k_7	0.40	y^{-1}
Surface water	to	sinks	k_8	0.80	y^{-1}
Soil	to	surface water	k_9	0.0006	y^{-1}
Soil	to	deeper soil layers (sinks)	k_{10}	0.022	y^{-1}

detection systems were used in this study. The ICPES has a detection limit for lead of $0.05 \text{ mg } \ell^{-1}$. The calculated concentration is well below this level. The SSMS has a detection limit of $0.001 \text{ mg } \ell^{-1}$ for lead. No lead was detected in any surface water samples in either the autumn 1977 sampling or the spring 1978 sampling. The calculated level is very close to the minimum detection capability, and therefore it is not too surprising that no lead was detected in any of the surface water samples.

Soil was sampled to a depth of 5 cm. The average result for these samples is shown in Table 3. The agreement between measured and calculated values is good.

Lead levels in ground water collected from springs were undetectable

Table 3. Comparison of calculated steady - state levels with field measurements from the Great Smoky Mountains National Park

Component	Calculated level	Measured level
C_A^* - Vegetation	$148 \mu\text{g g}^{-1}$	$34 \text{ to } 40 \mu\text{g g}^{-1}$ (Moss samples from understorey)
C_B^* - Forest litter	$239 \mu\text{g g}^{-1}$	$273 \mu\text{g g}^{-1}$
C_C^* - Surface water	$0.002 \text{ mg } \ell^{-1}$	None detected by ICPES (Detection limit = $0.05 \text{ mg } \ell^{-1}$) None detected by SSMS (Detection limit = $0.001 \text{ mg } \ell^{-1}$)
C_D^* - Soil	$18.5 \mu\text{g g}^{-1}$	$16 \mu\text{g g}^{-1}$
C_E^* - Heterotrophs	Not calculated	Not measured
C_F^* - Ground water	$0.0005 \text{ mg } \ell^{-1}$	None detected by ICPES (Detection limit = $0.05 \text{ mg } \ell^{-1}$) None detected by SSMS (Detection limit = $0.001 \text{ mg } \ell^{-1}$)

as was the case for surface water. The calculated level in ground water is somewhat lower than in surface water.

In addition to checking calculated values against measured values from the study area, comparison can also be made with estimates from the literature. For example, both Van Hook, Harris and Henderson (1977) and Rolfe and Jennett (1975) estimated that about 2 per cent of the lead input into an area leaves that area by surface water. If the calculated concentration of lead in water of $0.002 \text{ mg } \ell^{-1}$ is multiplied by the water lost per hectare per year (86.5×10^5 litres), this gives the total lead lost in a year. When this figure is divided by the total lead input, the fractional amount lost is estimated to be approximately 5 per cent, slightly higher than the figures mentioned above.

4.0 Exposure commitment analysis

4.1 Introduction and basic relationships

So far estimates of the steady-state concentrations of lead in the various compartments of the forest ecosystem have been determined from the measured input of lead from the atmosphere and estimates of the masses of the various compartments and the rate constants for transfers between compartments. These calculated values have good correspondence with the measured values from the field study.

Additional analysis of the system is accomplished by evaluating exposure commitments. The development and application of the exposure commitment method to environmental transport of pollutants have been under way at the Monitoring and Assessment Research Centre (MARC) for several years. O'Brien (1979) developed the formal mathematical relationships for this approach and applied it to estimating man's exposure to lead. Barry (1979) also described the commitment concept and illustrated its applicability by using mercury as an example. Miller and Buchanan (1979) applied the concept to the atmospheric transport of mercury.

The basis of the exposure commitment method is the determination of transfer coefficients. Whereas in the kinetic model the rate constants (k_i) are used to estimate the fractional amount of pollutant passing out of compartment i per unit time, in the exposure commitment method the transfer coefficients (P_{ij}) are used to describe the fractional transfer over all time of the pollutant moving from compartment i to compartment j . The use of transfer coefficients allows estimates to be made of total exposure to a receptor for any amount or input rate of pollutant into the system.

The exposure commitment (E_i) is defined as the integral of the concentration in compartment i over all time, thus :

$$E_i = \int_0^{\infty} C_i(t) dt$$

The transfer coefficient is defined as :

$$P_{ij} = \frac{E_j}{E_i} = \frac{\int_0^{\infty} C_j(t) dt}{\int_0^{\infty} C_i(t) dt}$$

It can be shown mathematically (O'Brien 1979, Barry 1979) that at steady state the transfer coefficient between compartments is equal to the ratio of the steady-state concentration of the pollutant in the receptor compartment to the steady-state concentration of the pollutant in the donor compartment:

$$P_{ij} = \frac{C_j^*}{C_i^*}$$

where P_{ij} is the transfer coefficient between compartments i and j . In the general case for transfer through a series of compartments, the steady-state concentration in a reservoir is obtained by sequential multiplication of transfer coefficients and the steady-state concentration in the initial reservoir of the chain (O'Brien 1979).

$$C_N^* = P_{N-1,N} P_{N-2,N-1} \dots P_{12} C_1^*$$

The relationship between the steady-state concentration in the reservoir n and the constant input rate q_i from the source S_i is defined as

$$C_N^* = P_{S_i,N} q_i$$

The relationship between steady-state concentrations or between a steady-state concentration and a constant input rate is thus expressed by a combination of transfer coefficients. In actual systems, the situation is usually more complicated because of multiple sources, parallel pathways and feedback loops. It will be assumed that the systems are linear and the superposition principle is valid. Contributions to steady-state concentrations from various pathways are additive. The relationships for some basic transfer sequences are reviewed in the following diagrams.

Straight chain

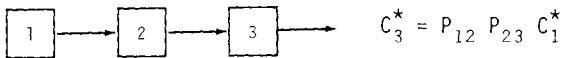

Parallel pathways

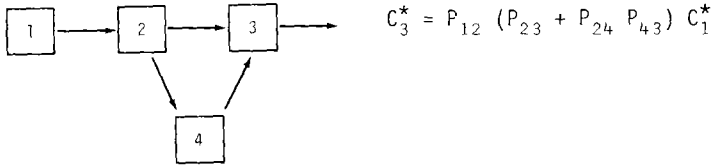

Feedback loop

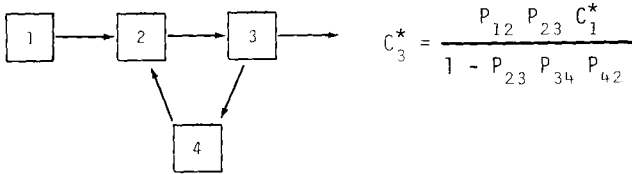

The relationship for the feedback loop may be derived by noting that

$$C_3^* = P_{23} C_2^*$$

$$C_2^* = P_{12} C_1^* + P_{34} P_{42} C_3^*$$

These equations are combined with the resultant equation solved for the steady-state concentration in compartment 3 in terms of the steady-state concentration in compartment 1.

Parallel pathways in feedback loop

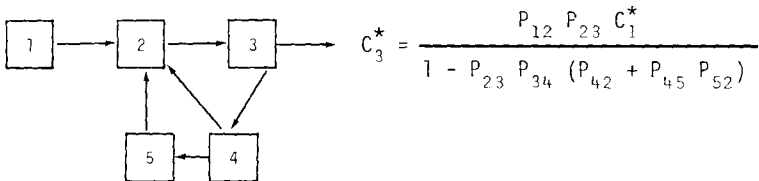

For parallel pathways in the feedback loop, the situation is similar to the simple feedback system except that P_{42} is replaced by the sum of the parallel pathways.

In general for the feedback systems, the numerator of the relationship is the expression obtained assuming no feedback. The denominator is one minus the recycle fraction. The recycle fraction is the product of transfer coefficients around the loop or the sum of such products for multiple loops.

4.2 Expressions for lead concentrations in the forest ecosystem

The relationships between steady-state concentrations and the constant input rates in the model for lead transfer in the forest ecosystem can now be given. The contributions to the concentrations are computed for the separate pathways from each source. For example, the notation ${}^1C_B^*$ denotes the steady-state concentration in compartment B due to pollutant release from source 1.

Source to Litter (B)

Pathway 1

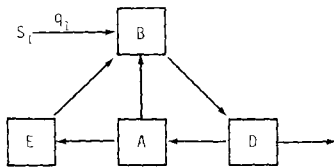

$${}^1C_B^* = \frac{P_{S_1 B} q_1}{1 - P_{BD} P_{DA} (P_{AB} + P_{AE} P_{EB})}$$

Pathway 2

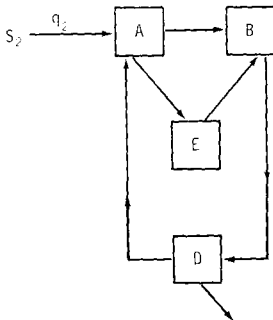

$${}^2C_B^* = \frac{P_{S_2 A} q_2 (P_{AB} + P_{AE} P_{EB})}{1 - P_{BD} P_{DA} (P_{AB} + P_{AE} P_{EB})}$$

Source to Soil (D)

Pathway 1

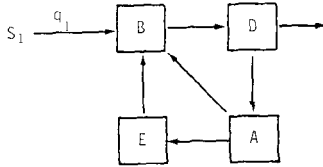

$${}^1C_D^* = \frac{P_{S_1 B} q_1 P_{BD}}{1 - P_{BD} P_{DA} (P_{AB} + P_{AE} P_{EB})}$$

Pathway 2

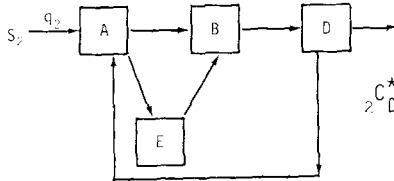

$${}^2C_D^* = \frac{P_{S_2 A} q_2 (P_{AB} + P_{AE} P_{EB}) P_{BD}}{1 - P_{BD} P_{DA} (P_{AB} + P_{AE} P_{EB})}$$

Source to vegetation (A)

Pathway 1

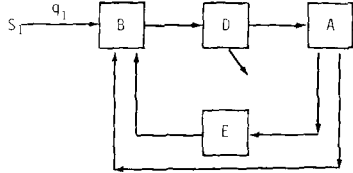

$${}^1C_A^* = \frac{P_{S_1 B} q_1 P_{BD} P_{DA}}{1 - P_{BD} P_{DA} (P_{AB} + P_{AE} P_{EB})}$$

Pathway 2

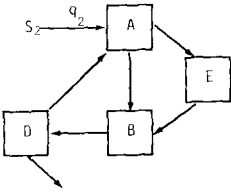

$${}^2C_A^* = \frac{P_{S_2A} q_2}{1 - P_{BD} P_{DA} (P_{AB} + P_{AE} P_{EB})}$$

Source to surface water (C)

Pathway 1

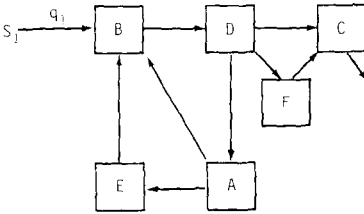

$${}^1C_C^* = \frac{P_{S_1B} q_1 P_{BD} (P_{DC} + P_{DF} P_{FC})}{1 - P_{DA} P_{BD} (P_{AB} + P_{AE} P_{EB})}$$

Pathway 2

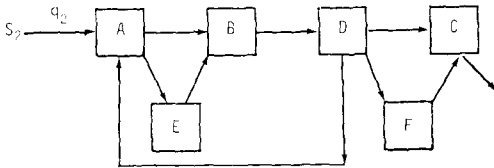

$${}^2C_C^* = \frac{P_{S_2A} q_2 (P_{AB} + P_{AE} P_{EB}) P_{BD} (P_{DC} + P_{DF} P_{FC})}{1 - P_{DA} P_{BD} (P_{AB} + P_{AE} P_{EB})}$$

Pathway 3



It is noted that in each case the same recycle loop is involved. The denominator is thus identical in each expression. It may also be noted that

$${}_1C_D^* = P_{BD} {}_1C_B^*$$

$${}_2C_D^* = P_{BD} {}_2C_B^*$$

$${}_1C_A^* = P_{DA} {}_1C_D^*$$

$${}_1C_C^* = (P_{DC} + P_{DF} P_{FC}) {}_1C_D^*$$

$${}_2C_C^* = (P_{DC} + P_{DF} P_{FC}) {}_2C_D^*$$

4.3 Evaluation of transfer coefficients

The next task is to evaluate the transfer coefficients. It is not possible simply to take the ratios of measured or calculated steady-state concentrations, since the contributions from the various pathways are superimposed. It will thus be necessary to apportion the steady-state concentration in a reservoir due to the separate input routes into the compartment. The input rates can be determined since the concentrations in the donor reservoirs have been calculated and the compartment masses and transfer rate constants have been estimated. Assuming first order kinetics, the transfer rate of lead equals the amount of lead in the donor reservoir times the rate constant for the transfer. Thus, for the transfer from compartment i to compartment j , the input rate or flux is

$$F_{ij}^* = k_{ij} Q_i^* = k_{ij} C_i^* M_j$$

The contributions to the steady-state concentration in the receiving reservoir will be assumed to be directly proportional to the constant input rates. This assumption is probably generally true for lead. However, if it were shown that passage of a pollutant through a compartment involved an alteration in chemical form which affects its subsequent behaviour, then some correction for this phenomenon would be required. In Table 4 are given the estimated input rates by all pathways to the various compartments.

The transfer coefficients are evaluated in Table 5. The contribution to the steady-state concentration in compartment j due to transfer from source i is denoted ${}_iC_j^*$. The relative fractions in parentheses are those computed in Table 4. Only for soil and ground water are the input transfers from a single donor compartment. The calculated total concentrations in the compartments were given in Table 3.

4.4 Evaluation of compartment concentrations or exposure commitments

The values of the transfer coefficients from Table 5 can now be inserted into the formulae given above (Section 4.2) for the contributions to the steady-state concentrations from each source. The results are given in Table 6. As a first step the contributions per unit input rate ${}_iC_j^*/q_i$ may be evaluated. These may be designated, $P'_{S_i,j}$, the transfer coefficient from source S_i to compartment j , where the prime indicates that recycling is included. Then, multiplying by the input rates as measured for the forest ecosystem, as given in Table 2, the contributions to the steady-state concentrations are determined. The total concentrations agree with the results of the direct calculations (Table 3).

The largest input rate and also the dominant contributor to the steady-state concentrations is from the source which gives rise to deposition of lead onto vegetation (S_2). The measured input rates (q_i) have been associated with separate sources in the model. These sources, however, all originate in air. The relationship between the concentration of lead in air and the input rates can also be given. For example, the transfer coefficient between air and S_2 is

$$P_{air,S_2} = \frac{q_2}{C_{air}^*} = \frac{0.26 \text{ kg ha}^{-1} \text{ y}^{-1}}{73 \text{ ng m}^{-3}} = 0.0035 \frac{\text{kg ha}^{-1} \text{ y}^{-1}}{\text{ng m}^{-3}}$$

Table 4. Steady-state input rates of lead to environmental compartments

Transfer pathway	Formula for determination	(Input rate) (g ha ⁻¹ y ⁻¹)	Pathway contribution to total input to the compartment (per cent)
To vegetation (A)			
<i>from source 2 (S₂)</i>	q_2	260	32
<i>from soil (D)</i>	$C_D^* M_D k_4$	560	68
		<hr/> Total 820	
To litter (B)			
<i>from source 1 (S₁)</i>	q_1	69	8
<i>from vegetation (A)</i>	$C_A^* M_A k_1$	696	78
<i>from heterotrophs (E)</i>	$C_E^* M_E k_3 = C_A^* M_A k_2$	123	14
		<hr/> Total 888	
To heterotrophs (E)			
<i>from vegetation (A)</i>	$C_A^* M_A k_2$	123	100
To soil (D)			
<i>from litter (B)</i>	$C_B^* M_B k_5$	884	100
To ground water (F)			
<i>from soil (D)</i>	$C_D^* M_D k_6$	7.0	100
To surface water (C)			
<i>from sources 3 (S₃)</i>	q_3	0.10	0.6
<i>from ground water (F)</i>	$C_F^* M_F k_7$	7.22	45.8
<i>from soil (D)</i>	$C_D^* M_D k_9$	8.44	53.6
		<hr/> Total 15.76	

Table 5. Transfer coefficients

Transfer pathway	Formula for determination	Value of transfer coefficient
To vegetation (A) <i>from source 2 (S₂)</i>	$P_{S_2A} = \frac{{}_2C_A^*}{q_2} = \frac{C_A^*(.32)}{q_2} = 180$	$\frac{\mu\text{g g}^{-1}}{\text{kg ha}^{-1} \text{ y}^{-1}}$
<i>from soil (D)</i>	$P_{DA} = \frac{{}_D C_A^*}{C_D^*} = \frac{C_A^*(.68)}{C_D^*} = 5.4$	$\frac{\mu\text{g g}^{-1}}{\mu\text{g g}^{-1}}$
To heterotrophs (E) <i>from vegetation (A)</i>	$P_{AE} = \frac{C_E^*}{C_A^*} = \frac{C_A^* M_A k_2 / M_E k_3}{C_A^*} = 2.0$	$\frac{\mu\text{g g}^{-1}}{\mu\text{g g}^{-1}}$
To litter (B) <i>from source 1 (S₁)</i>	$P_{S_1B} = \frac{{}_1 C_B^*}{q_1} = \frac{C_B^*(.08)}{q_1} = 280$	$\frac{\mu\text{g g}^{-1}}{\text{kg ha}^{-1} \text{ y}^{-1}}$
<i>from vegetation (A)</i>	$P_{AB} = \frac{{}_A C_B^*}{C_A^*} = \frac{C_B^*(.78)}{C_A^*} = 1.3$	$\frac{\mu\text{g g}^{-1}}{\mu\text{g g}^{-1}}$
<i>from heterotrophs (E)</i>	$P_{EB} = \frac{{}_E C_B^*}{C_E^*} = \frac{C_B^*(.14)}{C_A^* M_A k_2 / M_E k_3} = 0.12$	$\frac{\mu\text{g g}^{-1}}{\mu\text{g g}^{-1}}$
To soil (D) <i>from litter (B)</i>	$P_{BD} = \frac{C_D^*}{C_B^*} = 0.077$	$\frac{\mu\text{g g}^{-1}}{\mu\text{g g}^{-1}}$
To ground water (F) <i>from soil (D)</i>	$P_{DF} = \frac{C_F^*}{C_D^*} = 2.7 \times 10^{-5}$	$\frac{\text{mg } \ell^{-1}}{\mu\text{g g}^{-1}}$
To surface water (C) <i>from source 3 (S₃)</i>	$P_{S_3C} = \frac{{}_3 C_C^*}{q_3} = \frac{C_C^*(.006)}{q_3} = 0.12$	$\frac{\text{mg } \ell^{-1}}{\text{kg ha}^{-1} \text{ y}^{-1}}$
<i>from ground water (F)</i>	$P_{FC} = \frac{{}_F C_C^*}{C_F^*} = \frac{C_C^*(.458)}{C_F^*} = 1.8$	$\frac{\text{mg } \ell^{-1}}{\text{mg } \ell^{-1}}$
<i>from soil (D)</i>	$P_{DC} = \frac{{}_D C_C^*}{C_D^*} = \frac{C_C^*(.536)}{C_D^*} = 5.8 \times 10^{-5}$	$\frac{\text{mg } \ell^{-1}}{\mu\text{g g}^{-1}}$

Table 6. Contributions to steady-state concentrations

Compartment	Concentration per unit input rate (Transfer coefficient including recycling)	Concentration for measured input rates
Litter (B)	$\frac{{}_1C_B^*}{q_1} = P'_{S_1B} = 730$	$\frac{\mu\text{g g}^{-1}}{\text{kg ha}^{-1} \text{y}^{-1}}$
	$\frac{{}_2C_B^*}{q_2} = P'_{S_2B} = 730$	$\frac{\mu\text{g g}^{-1}}{\text{kg ha}^{-1} \text{y}^{-1}}$
	Total	$C_B^* = 239 \mu\text{g g}^{-1}$
Soil (D)	$\frac{{}_1C_D^*}{q_1} = P'_{S_1D} = 56$	$\frac{\mu\text{g g}^{-1}}{\text{kg ha}^{-1} \text{y}^{-1}}$
	$\frac{{}_2C_D^*}{q_2} = P'_{S_2D} = 56$	$\frac{\mu\text{g g}^{-1}}{\text{kg ha}^{-1} \text{y}^{-1}}$
	Total	$C_D^* = 18.5 \mu\text{g g}^{-1}$
Vegetation (A)	$\frac{{}_1C_A^*}{q_1} = P'_{S_1A} = 310$	$\frac{\mu\text{g g}^{-1}}{\text{kg ha}^{-1} \text{y}^{-1}}$
	$\frac{{}_2C_A^*}{q_2} = P'_{S_2A} = 480$	$\frac{\mu\text{g g}^{-1}}{\text{kg ha}^{-1} \text{y}^{-1}}$
	Total	$C_A^* = 148 \mu\text{g g}^{-1}$
Surface water (C)	$\frac{{}_1C_C^*}{q_1} = P'_{S_1C} = 0.006$	$\frac{\text{mg l}^{-1}}{\text{kg ha}^{-1} \text{y}^{-1}}$
	$\frac{{}_2C_C^*}{q_2} = P'_{S_2C} = 0.006$	$\frac{\text{mg l}^{-1}}{\text{kg ha}^{-1} \text{y}^{-1}}$
	$\frac{{}_3C_C^*}{q_3} = P'_{S_3C} = 0.12$	$\frac{\text{mg l}^{-1}}{\text{kg ha}^{-1} \text{y}^{-1}}$
	Total	$C_C^* = 0.0020 \text{ mg l}^{-1}$

The transfer coefficients between input rate (i.e. deposition rate) and concentrations in compartments may be multiplied by this factor to obtain the transfer coefficient of lead from air to the environmental compartments. That is for transfer from air to compartment j via pathway 2 which is the designation for input to vegetation in the model

$${}_2P'_{\text{air } j} = P_{\text{air}} \cdot s_2 \cdot P'_{s_2 j}$$

Similar procedures can be followed for the other source pathways. The additional values of transfer coefficients are given in Table 7. The transfer coefficients can be combined by addition to give the total transfer of lead in air via all three pathways to the environmental compartments,

$$\text{i.e. } P'_{\text{air } j} = {}_1P'_{\text{air } j} + {}_2P'_{\text{air } j} + {}_3P'_{\text{air } j}$$

If the concentration of lead in air in the park were to change to any other value, the resultant steady-state concentrations can be determined by multiplying the air concentration by these transfer coefficients. Alternatively, the exposure commitments from a specific input to a compartment or from a given exposure commitment to air, can be determined. In these cases the units of time are inserted in the numerator and denominator of the transfer coefficients. As an example of this procedure consider the consequences of an exposure commitment to air of 100 ng y m^{-3} . The corresponding exposure commitment to litter via all pathways would be

$$\begin{aligned} E_B = P'_{\text{air},B} E_{\text{air}} &= 3.2 \frac{\mu\text{g y g}^{-1} \text{ litter}}{\text{ng y m}^{-3} \text{ air}} 100 \text{ ng y m}^{-3} \\ &= 320 \mu\text{g y g}^{-1} \text{ litter} \end{aligned}$$

This result is equivalent to the area under the curve representing concentration in the litter compartment from the specific input for as long as is necessary for this lead to be completely cleared from the system. The exposure commitment gives an effective measure of the exposure of the compartment to the pollutant input.

Table 7. Transfer coefficients for lead from air to environmental compartments

Transfer pathway	Transfer coefficient	
Pathway 1		
Transfer from air to litter (B)	${}_1P'_{\text{air},B} = 0.69$	$\frac{\mu\text{g g}^{-1}}{\text{ng m}^{-3}}$
to soil (D)	${}_1P'_{\text{air},D} = 0.053$	$\frac{\mu\text{g g}^{-1}}{\text{ng m}^{-3}}$
to vegetation (A)	${}_1P'_{\text{air},A} = 0.29$	$\frac{\mu\text{g g}^{-1}}{\text{ng m}^{-3}}$
to surface water (C)	${}_1P'_{\text{air},C} = 5.7 \times 10^{-6}$	$\frac{\text{mg l}^{-1}}{\text{ng m}^{-3}}$
Pathway 2		
Transfer from air to litter (B)	${}_2P'_{\text{air},B} = 2.5$	$\frac{\mu\text{g g}^{-1}}{\text{ng m}^{-3}}$
to soil (D)	${}_2P'_{\text{air},D} = 0.20$	$\frac{\mu\text{g g}^{-1}}{\text{ng m}^{-3}}$
to vegetation (A)	${}_2P'_{\text{air},A} = 1.7$	$\frac{\mu\text{g g}^{-1}}{\text{ng m}^{-3}}$
to surface water (C)	${}_2P'_{\text{air},C} = 2.1 \times 10^{-5}$	$\frac{\text{mg l}^{-1}}{\text{ng m}^{-3}}$
Pathway 3		
Transfer from air to surface water (C)	${}_3P'_{\text{air},C} = 1.6 \times 10^{-7}$	$\frac{\text{mg l}^{-1}}{\text{ng m}^{-3}}$
All Pathways		
Transfer from air to litter (B)	$P'_{\text{air},B} = 3.2$	$\frac{\mu\text{g g}^{-1}}{\text{ng m}^{-3}}$
to soil (D)	$P'_{\text{air},D} = 0.25$	$\frac{\mu\text{g g}^{-1}}{\text{ng m}^{-3}}$

Table 7. contd.

<i>to vegetation (A)</i>	$P'_{\text{air,A}} = 2.0$	$\frac{\mu\text{g g}^{-1}}{\text{ng m}^{-3}}$
<i>to surface water (C)</i>	$P'_{\text{air,C}} = 2.7 \times 10^{-5}$	$\frac{\text{mg l}^{-1}}{\text{ng m}^{-3}}$

5.0 Conclusions

A compartment model representing an environmental system can be analysed either by solving the time-dependent equations describing the pollutant transport, generally assuming first order kinetics, or by determining the time-independent transfer coefficients to evaluate exposure commitments or to relate steady-state concentrations in pathway compartments.

The most complete analysis is provided by the time-dependent or dynamic description of the system. An extensive data base is required to estimate the numerous transfer rate constants and compartment masses or volumes. If the steady-state situation applies, the solutions are greatly simplified. This was, in the first instance, the approach made to the analysis of lead behaviour in the Great Smoky Mountains Biosphere Reserve. Values were assigned to each parameter based upon measurement and literature review, and the steady-state concentrations were calculated. Good agreement was obtained between calculated concentrations and measurement results in the various environmental media.

The steady-state concentrations play a fundamental role in the exposure commitment approach, namely, in determining the transfer coefficients for pollutant transport through a compartment system. These relationships have also been illustrated for the Great Smoky Mountains environment. The source inputs were assumed to occur at three points in the system, requiring rather complex expressions for the transfer coefficients and the contributions to compartment concentrations. Somewhat simpler transfers could have been assumed if less were known about the system, that is for some pathways or compartments not distinguished from one another.

The relationship between steady-state concentrations and transfer

coefficients points to the fact that the latter may be most conveniently determined from the measured levels in appropriate environmental compartments. To do this, some confidence would be needed that a state of actual or near equilibrium exists in the system. Further, to determine all the transfer coefficients would require measured values in each of the various compartments. To apply the exposure commitment method to a specific source pathway, it is necessary to make some estimate of the contributions from the various sources to steady-state concentrations. However, to determine the transfer coefficients for the combined transfer via all pathways, one can simply take the ratios of the measured concentrations.

The transfer coefficients are a convenient means of expressing compartment interrelationships, and the combinations of transfer coefficients unite the system in the exposure commitment approach. The transfer coefficients enable one to obtain estimates of the exposure commitments to pathway compartments from the release of specific pollutant amounts into the system or estimates of the altered steady-state concentrations which will become established for constant, continuing increased or decreased source inputs.

The detailed analysis of an environmental system is particularly helpful with regard to monitoring systems design. In the first case, the measurements that are necessary for efficient monitoring are indicated, as are measurements that would help improve the model. For example, it would be useful to obtain estimates of the lead concentration in vegetation from the overstorey. In addition, to help support the model one might want to use more sensitive analytical techniques to determine the levels of lead in ground water and stream water.

In another view toward monitoring systems design, the analysis makes it possible to isolate those areas most responsive to sampling and helps eliminate those areas in which further sampling would be counter-productive. For example, the model indicates that lead accumulates to relatively high levels in forest litter. This could be a key area to sample in a prolonged monitoring programme, possibly eliminating other samples such as soil, water or certain types of vegetation. Further, once the model has been worked out, only key measurements such as input data and a few compartment level measurements need be made. The other levels can then be calculated from the dynamic equations of the system or the exposure commitment analysis.

Acknowledgements

This report was prepared at MARC under Dr Athol Rafter, Director. I wish to express my thanks to him for his support and his excellent critical review of the manuscript and to B. G. Bennett and J. M. Buchanan of MARC for their assistance and advice.

References

- Alloway, B. J. and Davies, B. E. 1971 Heavy metal content of plants growing on soils contaminated by lead mining. *J. Agri. Sci.* **76**, 321-323.
- Anderson, G. V., Young, D. R., McDermott, D. J., Sherwood, M. J., Mearns, A. J. and Lunt, O. R. 1975 Marine organisms in the southern California bight as indicators of pollution. International Conference on Heavy Metals in the Environment, Toronto, Canada, 955-972.
- Anas, R. E. and Wilson, A. J. 1970 Organochlorine pesticides in nursing fur seal pups. *Pestic. Monit. J.* **4** (3), 114-116.
- Anon. 1970a Man's impact on the global environment, assessment and recommendations for action. MIT Press, Cambridge, Massachusetts. 319 pp.
- Anon. 1970b A global network for environmental monitoring. A report to the Executive Committee, U.S. National Committee for the International Biological Program. Ad hoc Task Force on GNEM.
- Anon. 1974 Programme on man and the biosphere (MAB), Task Force on: Pollution Monitoring and Research in the Framework of the MAB Programme organized jointly by UNESCO and UNEP. Final Report. MAB Report Series No. 20, Moscow, U.S.S.R.
- Barry, P. J. 1979 *An introduction to the exposure commitment concept with reference to environmental mercury*. MARC Report No. 12, Monitoring and Assessment Research Centre, Chelsea College, University of London.
- Bormann, F. H., Likens, G. E., Siccama, T. G., Pierce, R. S. and Eaton, J. S. 1974 The export of nutrients and recovery of stable conditions following deforestation at Hubbard Brook. *Ecological Monographs* **44**, 255-277.
- Bray, R. S. and Gorham, E. 1964 Litter production in forests of the world. *Advances in Ecological Research* **2**, 101-157.
- Brown, K. W., Wiersma, G. B. and Frank, C. W. 1979 Monitoring device for sampling air in remote areas. U.S. Environmental Protection Agency. In review.
- Cartwright, B., Merry, R. H. and Tiller, K. G. 1976 Heavy metal contamination of soils around a lead smelter at Port Pirie, South Australia. *Australian J. of Soil Research* **15**, 69-81.
- Cawse, P. A. 1974 A survey of atmospheric trace elements in the U.K. Atomic Energy Research Establishment, Harwell, Berkshire. AERE-R7669.
- Cawse, P. A. and Pierson, D. H. 1972 An analytical study of trace elements

- in the atmospheric environment. Atomic Energy Research Establishment, Harwell, Berkshire. AERE-R7134.
- Chow, T. J. 1970 Lead accumulation in roadside soil and grass. *Nature* **225**, 295-296.
- Chow, T. J. and Earl, J. L. 1970 Lead aerosols in the atmosphere: increasing concentrations. *Sci.* **169**, 577-580.
- Elgmork, K., Hagen, A. and Langeland, A. 1973 Polluted snow in southern Norway during the winters 1968-1971. *Environ. Pollut.* **4**, 41-52.
- Franklin, J. F. 1974 The conceptual basis for selection of United States biosphere reserves and features of established areas. Presented at the U.S.-U.S.S.R. Symposium on Biosphere Reserves, May 5 and 6, Moscow, U.S.S.R.
- Franklin, J. F. 1977 The biosphere reserve program in the United States. *Sci.* **195**, 262-267.
- Fuller, W. H., Korte, N. E., Miebla, E. E. and Alessi, B. A. 1976 Contribution of the soil to the migration of certain common and trace elements. *Soil Science* **122** (4), 223-235.
- Goodman, G. T. and Roberts, T. M. 1971 Plants and soils as indicators of metals in the air. *Nature* **231**, 287-292.
- Gosz, J. P., Likens, G. E. and Bormann, F. H. 1972 Nutrient content of litter fall on the Hubbard Brook experimental forest, New Hampshire. *Ecology* **53** (5), 769-784.
- Hirao, Y. and Patterson, C. C. 1974 Lead aerosol pollution in the High Sierra over-rides natural mechanisms which exclude lead from a food chain. *Sci.* **184**, 989-992.
- Hynes, H. B. N. 1970 *The ecology of running waters*. University of Toronto Press.
- Jaklevic, J. M., Loo, B. W. and Goulding, F. S. 1976 Photon induced X-ray fluorescence analysis using energy dispersive detector and dichotomous sampler. X-ray Fluorescence Analysis of Environmental Samples Symposium, Chapel Hill, NC, 26-28 January.
- Jaklevic, J. M., Goulding, F. S., Jarrett, B. V. and Meng, J. D. 1973 Applications of X-ray fluorescence techniques to measure elemental composition of particles in the atmosphere. 166th American Society Meeting on Analytical Methods applied to Air Pollution Measurements, Dallas, TX, 8-13 April.
- Johnson, F. L. and Risser, P. G. 1974 Biomass, annual net primary production and dynamics of six mineral elements in a Post Oak-Black Jack Oak forest. *Ecology* **55**, 1246-1258.
- Johnson, M. S., McNally, T. and Putwain, P. D. 1977 Revegetation of metalliferous mine spoil contaminated by lead and zinc. *Environ. Pollut.* **12**, 261-277.
- Johnson, N. M., Reynolds, R. C. and Likens, G. E. 1972 Atmospheric sulphur: its effect on the chemical weathering of New England. *Sci.* **177**, 514-516.

- Karubian, J. F. 1974 Polluted groundwater: estimating the effects of man's activities. U.S. Environmental Protection Agency. EPA 680/4-74-002, 99 pp.
- Kee, N. S. and Bloomfield, C. 1962 The effect of flooding and aeration on the mobility of certain trace elements in soils. *Plant and Soil* **16**, 108-135.
- Kormondy, E. J. 1969 *Concepts of ecology*. Prentice-Hall Inc., Englewood Cliffs, New Jersey. 207 pp.
- Korte, N. E., Skopp, J., Fuller, W. H., Niebla, E. E. and Alessi, B. A. 1976 Trace element movement in soils: influence of soil physical and chemical properties. *Soil Science* **122** (6), 350-359.
- Lagerwerff, J. V. and Specht, A. W. 1970 Contamination of roadside soil and vegetation with cadmium, nickel, lead and zinc. *Env. Sci. and Tech.* **4** (7), 583-586.
- Lazarus, A. L., Lorange, E. and Lodge, J. P. 1970 Lead and other metal ions in United States precipitation. *Env. Sci. and Tech.* **4** (1), 55-58.
- MacLean, A. J., Halstead, R. L. and Finn, B. J. 1972 Extractability of added lead in soils and its concentration in plants. *Canadian J. Soil Science* **49**, 327-334.
- Miller, D. R. and Buchanan J. M. 1979 *Atmospheric transport of mercury: exposure commitment and uncertainty calculations*. MARC Report No. 14. Monitoring and Assessment Research Centre, Chelsea College, University of London.
- Monk, C. D., Child, G. I. and Nicholson, S. A. 1970 Biomass, litter and leaf surface area estimates of an Oak-Hickory forest. *Oikos* **21**, 138-141.
- Moyers, J. L., Ranwieler, L. E., Hopf, S. B. and Korte, N. E. 1977 Evaluation of particulate trace species in south-west desert atmosphere. *Env. Sci. and Tech.* **11**, 789-794.
- Munn, R. E. 1973 Global environmental monitoring system (GEMS) action plan for phase I. SCOPE Report No. 3, International Council of Scientific Unions.
- O'Brien, B. J. 1979 *The exposure commitment method with application to exposure of man to lead pollution*. MARC Report No. 13. Monitoring and Assessment Research Centre, Chelsea College, University of London.
- Rabinowitz, M. 1972 Plant uptake of soil and atmospheric lead in southern California. *Chemosphere* **4**, 175-180.
- Reichle, D. E., Crossley, D. A., Edwards, C. A., McBrayer, J. F. and Sollins, P. 1973 Organic matter and ¹³⁷Cs turnover in forest soil by earthworm populations: application of bioenergetic models to radionuclide transport. In: *Radionuclides in Ecosystems* (Ed. D. J. Nelson) Oak Ridge, USAEC. 240-246.
- Reiners, W. A. 1972 Structure and energetics of three Minnesota forests. *Ecological Monographs* **42** (1), 71-94.
- Rolfe, G. L. and Jennett, J. C. 1975 Environmental lead distribution in relation to automobile and mine and smelter sources. Heavy Metals in the

- Aquatic Environment. Proceedings International Conference, Nashville, Tennessee. Pergamon Press.
- Roschow, J. J. 1974 Estimates of above ground biomass and primary productivity in a Missouri forest. *J. of Ecology* **62** (2), 567-587.
- Schlesinger, W. H., Reiners, W. A. and Knupman, D. S. 1974 Heavy metal concentrations and deposition in bulk precipitation in montane ecosystems of New Hampshire, U.S.A. *Environ. Pollut.* **6**, 39-47.
- Shanks, R. E. 1954 Climates of the Great Smoky Mountains. *Ecology* **35** (3), 354-361.
- Tyler, G. 1978 Leaching rates of heavy metal ions in forest soil. *Water, Air and Soil Pollution* **9**, 137-148.
- Van Hook, R. I., Harris, W. F. and Henderson, G. S. 1977 Cadmium, lead and zinc distributions and cycling in a mixed deciduous forest. *Ambio* **6**, 281-286.
- Ward, N. I., Reeves, R. D. and Brooks, R. R. 1975 Lead in soil and vegetation along a New Zealand state highway with low traffic volume. *Environ. Pollut.* **9**, 243-251.
- Weiss, H. V., Koide, M. K. and Goldberg, E. D. 1971 Mercury in a Greenland ice sheet: Evidence of recent input by man. *Sci.* **74**, 692-694.
- Whitaker, R. H. 1956 Vegetation of the Great Smoky Mountains. *Ecological Monographs* **26** (1), 1-80.
- Whitaker, R. H. 1966 Forest dimensions and production in the Great Smoky Mountains. *Ecology* **47** (1), 103-121.
- Whitaker, R. H., Bormann, F. H., Likens, G. E. and Siccama, T. G. 1974 The Hubbard Brook ecosystem study: Forest biomass and production. *Ecological Monographs* **44**, 233-252.
- Wiersma, G. B., Brown, K. W. and Crockett, A. B. 1978a Development of a pollutant monitoring system for biosphere reserves. U.S. Environmental Protection Agency, Las Vegas, Nevada. EPA-600/4-78-052, 133 pp.
- Wiersma, G. B., Brown, K. W. and Crockett, A. B. 1978b Development of a pollutant monitoring system for biosphere reserves and results of the Great Smoky Mountains pilot study. Proceedings, 4th Joint Conference on sensing of environmental pollutants, New Orleans, LA. 451-456.
- Wiersma, G. B., Brown, K. W., Herrmann, R., Taylor, C. and Pope, J. 1979a Great Smoky Mountains preliminary study for biosphere reserve pollutant monitoring. U.S. Environmental Protection Agency. In review.
- Wiersma, G. B., Frank, C. W., Brown, K. W. and Davidson, C. I. 1979b Lead particles in remote areas of Great Smoky Mountains Biosphere Reserve. U.S. Environmental Protection Agency. In review.
- Zoller, W. H., Gladney, E. S. and Duce, R. A. 1974 Atmospheric concentrations and sources of trace metals at the South Pole. *Sci.* **183**, 198-200.

All MARC publications are subject to peer review. Titles to date in the series are :

No.

- 1 *The ozone depletion problem (an example of harm commitment)* by Lester Machta
- 2 *Vanadium in the environment* by Siv Bengtsson and Germund Tyler
- 3 *Suggestions for the development of a hazard evaluation procedure for potentially toxic chemicals* by Robert C. Harriss
- 4 *The utility of the Nigerian peasant farmer's knowledge in the monitoring of agricultural resources* by David Barker, Julius Oguntoyinbo and Paul Richards
- 5 *Monitoring tropical forests: a review with special reference to Africa* by Timothy J. Synnott
- 6 *Radar design for determining the strength of tropical cyclones in the Bay of Bengal* by Harold W. Baynton
- 7 *Atmospheric pathways of sulphur compounds* by D. M. Whelpdale
- 8 *Environmental education in the United Kingdom Universities and Polytechnics: a compendium* by Kenneth Guy, Sally Turner and Lesley Williams
- 9 *Some methodological issues in the measurement, analysis and evaluation of peasant farmers' knowledge of their environment* by David Barker
- 10 *Air concentration and deposition rates from uniform area sources* by Lester Machta
- 11 *A handbook to estimate climatological concentration, deposition and horizontal fluxes of pollutants on a regional scale* by Lester Machta
- 12 *An introduction to the exposure commitment concept with reference to environmental mercury* by P. J. Barry
- 13 *The exposure commitment method with application to exposure of man to lead pollution* by B. J. O'Brien
- 14 *Atmospheric transport of mercury: exposure commitment and uncertainty calculations* by D. R. Miller and J. M. Buchanan
- 15 *Kinetic and exposure commitment analyses of lead behaviour in a biosphere reserve* by G. B. Wiersma

MONITORING AND ASSESSMENT RESEARCH CENTRE

Chelsea College, University of London

The Octagon Building, 459A Fulham Road, London SW10 0QX

Price
U.K. £3.00
Overseas U.S. \$4.00
Postage paid in the U.K.

ISBN 0 900918 14 2
© MARC, Chelsea College