



सत्यमेव जयते

MINISTRY OF URBAN DEVELOPMENT  
GOVERNMENT OF INDIA

# Toolkit for Comprehensive Mobility Plan (CMP) Revised (2014)



## Preparing a Comprehensive Mobility Plan (CMP) A Toolkit (Revised)

[www.iutindia.org](http://www.iutindia.org)

September 2014

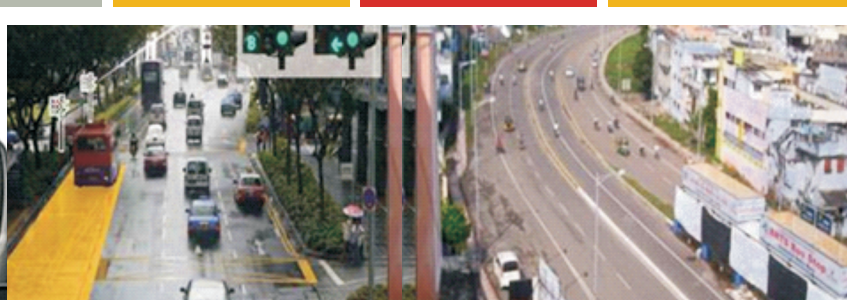



## **Toolkit for Comprehensive Mobility Plan (CMP) Revised 2014**

### **Institute of Urban Transport (India)**

1<sup>st</sup> Floor, Anand Vihar Metro Station Building,  
Entry adjacent to Gate No 1,  
Delhi - 110 092 (INDIA)  
Tel: (+91) 11 66578700 – 709  
Fax: (+91) 11 66578733/44



**The current revision of CMP toolkit is based on experiences from the review of existing CMP implementation done by IUT & TERI and the experience gained from preparation of Low-carbon Comprehensive Mobility Plans under the UNEP project "Promoting Low Carbon Transport in India" for the cities of Rajkot, Vishakhapatnam and Udaipur.**



[www.iutindia.org](http://www.iutindia.org)

The Institute of Urban Transport (India) is a premier professional non-profit making organisation under the purview of the Ministry of Urban Development, Government of India (MoUD). The National Urban Transport Policy (NUTP), 2006 has empowered IUT to serve as a National Level Facility for continuous advice and guidance on the principles of sustainable urban transport. The objective of the Institute is to promote, encourage and coordinate the state of the art of urban transport including planning, development, operation, education, research and management at the national level.

The Institute has been nominated as the project monitoring unit for Component 1A of the SUTP. IUT is responsible for overseeing the preparation of the training modules, subject toolkits and conduct of training of 1000 city officials in urban transport.



The Ministry of Urban Development (MoUD), Government of India (GoI) has initiated the Sustainable Urban Transport Project (SUTP) with support of Global Environment Facility (GEF) and the World Bank to foster a long-term partnership between GoI and state/local governments in the implementation of a greener environment under the ambit of the NUTP. The aim of the project is to achieve a paradigm shift in India's urban transport systems in favour of sustainable development. The MoUD is the nodal agency for the implementation of the project, to be implemented over a four-year period starting from May, 2010 to 30 November 2014. Project cost is Rs. 14,161.55 Million. The project development objective (PDO) is to promote environmentally sustainable urban transport in India and to improve the usage of environment-friendly transport modes through demonstration projects in selected cities.



Government of India  
**Ministry of Urban Development**  
 Preparing a Comprehensive Mobility  
 Plan CMP – A Toolkit

Supported by:



Federal Ministry for the  
 Environment, Nature Conservation  
 and Nuclear Safety

based on a decision of the Parliament  
 of the Federal Republic of Germany



[www.iutindia.org](http://www.iutindia.org)



IIT Delhi



કચ્છનું વિજ્ઞાનમંદિરમ્



# Foreword

---

I have great pleasure in presenting the revised toolkit for the preparation of Comprehensive Mobility Plan (CMP) for a city. The toolkit has been prepared jointly by the Institute of Urban Transport (IUT) India, a team of researchers and consultants from premier institutions in India, the United Nations Environment Programme (UNEP), and UNEP DTU Partnership. The revision of the toolkit has been carried out under the advice of MoUD.

The current revision of the toolkit is based on experiences from the review of existing CMP implementation done by IUT & TERI, and the preparation of Low-carbon Comprehensive Mobility Plans under the UNEP project “Promoting Low Carbon Transport in India” for the cities of Rajkot, Vishakhapatnam and Udaipur. The preparation process has also involved consultation with experts (27) on the first draft on 17 October 2013 and with the city officials and other stakeholders from states (22) on 25 November 2013. Their inputs have made a valuable contribution to the revision of the toolkit.

The revised toolkit has a clear focus on climate change and sustainable development and takes forward the process of integrating the actions necessary for the transport sector as per the “National Mission on Sustainable Habitat,” for which MoUD is the nodal ministry. The toolkit provides a clear guidance for integrating the inclusiveness agenda within the transport planning processes with a strong focus on integration of land use and transport bringing the CMP closer to the development plans/master plans of the city.

I congratulate all those who have contributed directly and indirectly to this task.

**Secretary**

**Ministry of Urban Development**





# Preface

---

In 2008 Ministry of Urban Development (MoUD), with the assistance of the Asian Development Bank (ADB), prepared and issued a toolkit for the preparation of a Comprehensive Mobility Plan (CMP) for cities. MoUD encouraged cities to prepare CMPs before seeking funding for urban transport projects under Jawaharlal Nehru National Urban Renewal Mission (JnNURM). More than 50 cities have prepared CMPs using the CMP toolkit. A critical review of some of the CMPs submitted by city authorities, undertaken by IUT and TERI, revealed that CMPs have not followed the toolkit in letter and spirit and do not meet the requirement of social, economic and environmental sustainability of urban transport.

Since then as part of National Action Plan on Climate Change, Government of India constituted 8 missions on various themes of national importance including National Mission on Sustainable Habitat with Ministry of Urban Development as the nodal ministry for this mission. The mission aims at making urban habitats sustainable through urban planning techniques, modal shift in favour of public transport and non-motorised transport and to achieve reduction in CO<sub>2</sub> emissions. The existing toolkit does not require and the CMPs have not estimated the long-term GHG (Green House Gases) emissions.

Simultaneously, the United Nations Environment Programme (UNEP) took up a project on promoting low carbon transport in India by taking up case studies of Udaipur, Rajkot and Vishakhapatnam. The project is endorsed by the Ministry of Environment and Forest, Government of India. As part of the project, a methodology has been developed for preparing Low Carbon Mobility Plan with a focus on improving the quality of local environment, social inclusiveness for all sections of society, genders and also reduction in GHG emissions.

Review and update of the toolkit for CMP was also necessary to incorporate various suggestions and recommendations of the expert committees and groups on urban transport and the policy enunciations by the Government of India in the recent past. Accordingly, Ministry of Urban Development directed IUT to review and revise the toolkit for CMP. IUT and UNEP discussed the work being done and agreed to collaborate and prepare the revised CMP toolkit.

The draft revised toolkit was discussed at the Expert Review Workshop held on 17th-18th October 2013 at IUT in which experts, study team members and other invitees participated. The agencies involved



in the revision provided inputs for the identified sections of the toolkit. Inputs from various reports of the expert committees and groups on urban transport of the 11<sup>th</sup> and 12<sup>th</sup> five-year plans, working group report on urban transport for NTDP, national mission on sustainable habitat, service level benchmarks, advisories issued by MoUD, code of practices for design of urban roads, global case studies on transport master plan such as London, Singapore and Bogota; have been taken into consideration while revising the toolkit. The revised draft toolkit was also discussed at a national level workshop held at Goa on 25-26 November 2013 with the city officials from various states across the country.

This revised toolkit for CMP has been prepared after taking the views of the experts, city officials and other stakeholders into consideration. Although it is based on the existing toolkit, the revised toolkit has almost been re-written. The authors have taken the methodology of the original CMP as the starting point to prepare the revised toolkit of the CMP, which has both low-carbon and inclusive transport agenda interwoven. It emphasises the need to promote sustainable urban transport and requires an assessment of improvement in GHG emission as a result of implementation of the CMP.

In terms of approach, the toolkit has moved from a deterministic forecasting approach to a more flexible scenario-based approach, relying on projections. The scenario-based approach takes two broad views for the future: i) which mimics the current development patterns and where the land use for future is closely tied to the master plan (or development plan) document and ii) where specific interventions for land use, infrastructures, public transport/non-motorised transport and the change in regulations for personal motorised transport are envisaged. The revised approach therefore allows the policy makers and stakeholders at the city level to make an assessment of the benefits they can gain from implementing the CMP approach.

In terms of comprehensiveness, the CMP toolkit has been modified to include new data collection formats so that information on different socio-economic groups and gender is explicitly collected and used for transport planning projections. The second change is with regards to environment and CO<sub>2</sub> emissions which involves the collection of data on vehicles (related to energy and emissions characteristics). The third aspect is related to safety. The more important aspect is that all these data are used to create information on future sustainable and low carbon transport scenarios, which are quantified in terms of indicators for mobility and accessibility, infrastructure and land use; safety and security; environmental impacts (including CO<sub>2</sub> emissions) and economic aspects. The indicators allow easy comparison with service-level benchmarks and can therefore aid policymakers and consultants at the city level.

The authors believe that the toolkit is a working document and after 5 years there could be a new context to which the toolkit may have to be adapted.

**Institute of Urban Transport (India)**

# Acknowledgement

---

The revised toolkit for Comprehensive Mobility Plan has been prepared for the Ministry of Urban Development (MoUD), Government of India, jointly by IUT and a team of researchers and consultants working on the UNEP project on “Promoting Low Carbon Transport in India”.

The team from IUT involved Mr. M.L. Chotani, Ms. Kanika Kalra and Ms. Vijaya Rohini Kodati whereas UNEP project team is comprised of Dr Anvita Arora, Dr. Subash Dhar, Mr. Ranjan Jyoti Dutta, Mr. Ravi Gadepalli, Ms. Deepty Jain, Prof. Darshini Mahadevia, Dr. Talat Munshi, Prof. P.R. Shukla and Prof. Geetam Tiwari.

The team expresses its heartfelt thanks to Shri O.P. Agarwal, D.G. IUT, Shri. B. I. Singal, Ex. D.G. IUT and Shri. S. K. Lohia, former OSD (UT) and Ex-officio JS MoUD for their advice and guidance from time to time in carrying out the revision of the toolkit.

The team would like to thank external experts, Ms Chhavi Dhingra, Ms. Akshima T Ghate, Prof. Sanjay Gupta, Ms. Nupur Gupta and Prof. Sewa Ram, who provided inputs for the toolkit at the expert workshop held at IUT on 17 October 2013. The team would also like to thank Ms. Kamala Ernest for her comments on the draft CMP and her constant support to the team.

The team would also like to thank participants from various cities, who provided inputs for the revision of the CMP toolkit at the workshop held at Goa on 25 November 2013.

The team would also like to acknowledge the consultants’ team who earlier prepared the CMP toolkit comprising Dr. Chiaki Kuranami, Mr. Christopher Rose and Mr. Satoshi Ogita under the technical assistance from Asian Development Bank.



# Table of Contents

---

|   |          |
|---|----------|
| Foreword .....  | v        |
| Preface.....  | vii      |
| Acknowledgement.....  | ix       |
| Abbreviations and Acronyms.....   | xv       |
| <b>Section 1: Introduction .....</b>  | <b>1</b> |
| Background.....   | 1        |
| What is a CMP? .....  | 1        |
| Need for Revision of CMP, 2008.....   | 2        |
| Vision of a CMP .....   | 2        |
| Scope of CMP .....  | 2        |
| Surveys for CMP Preparation .....   | 3        |
| Main Features of CMP .....  | 3        |
| Key Outcomes of a CMP.....  | 3        |
| Relationship Between a CMP and Other Existing Plans.....  | 3        |
| Relationship with CDP.....  | 4        |
| Relationship with the Master Plan.....  | 4        |
| Relationship with the CTTS .....  | 5        |
| Frequently Asked Questions on Comprehensive Mobility Plan.....                                    | 5        |
| Preparing for a CMP: Where to Start? .....  | 6        |
| Understanding Key CMP Tasks.....  | 6        |
| <b>Section II: Task Descriptions .....</b>  | <b>7</b> |
| <b>TASK 1: Defining the Scope of the CMP.....</b>   | <b>7</b> |
| Consultation for Validation of CMP.....   | 8        |
| <b>Task 2: Data Collection and Analysis of the Existing Urban Transport and Environment .....</b> | <b>8</b> |
| Task 2.1 Review of the City Profile .....   | 8        |



|  |           |
|--|-----------|
| Task 2.2 Delineation of Traffic Analysis Zones .....   | 9         |
| Task 2.3 Review of Land Use Pattern and Population Density .....                                   | 10        |
| Task 2.4 Review of the Existing Transport Systems .....  | 12        |
| Task 2.5 Study of Existing Travel Behaviour .....  | 14        |
| Task 2.6 Review of Energy and Environment .....  | 14        |
| Task 2.7 Service Level Benchmarks .....  | 16        |
| Task 2.8 Analysis and Indicators (Comparison with Benchmarks) .....                                | 17        |
| <b>Task 3: Development of Business as Usual (BAU) Scenario .....</b>                               | <b>20</b> |
| Task 3.1 Framework for Scenarios .....   | 20        |
| Task 3.2 Socio-Economic Projections .....  | 21        |
| Task 3.3 Land Use Transitions .....  | 21        |
| Task 3.4 Transport Demand Analysis.....  | 23        |
| Task 3.5 Technology Transitions.....   | 23        |
| Task 3.6 CO2 Emissions and Air Quality .....   | 25        |
| Task 3.7 Analysis and Indicators (Comparison with Benchmarks) .....                                | 29        |
| <b>Task 4: Development of Sustainable Urban Transport Scenarios .....</b>                          | <b>30</b> |
| Task 4.1 Framework for Scenario .....  | 30        |
| Task 4.2 Strategies for Sustainable Urban Transport Scenario .....                                 | 31        |
| Task 4.3 Transport Demand Analysis of Alternative Strategies for Sustainable Urban Transport ..... | 33        |
| Task 4.4 Technology Transitions under a Low Carbon Scenario .....                                  | 34        |
| Task 4.5 CO2 Emissions and Air Quality (Refer to tasks 3-6.) .....                                 | 35        |
| Task 4.6 Analysis and Indicators (Comparison with Benchmarks) .....                                | 35        |
| <b>Task 5: Development of Urban Mobility Plan .....</b>  | <b>36</b> |
| Task 5.1 Integrated Land Use and Urban Mobility Plan .....   | 36        |
| Task 5.2 Formulation of the Public Transport Improvement Plan.....                                 | 37        |
| Task 5.3 Preparation of Road Network Development Plan .....  | 38        |
| Task 5.4 Preparation of NMT Facility Improvement Plan .....  | 38        |
| Task 5.5 Freight Movement Plan.....  | 39        |
| Task 5.6 Mobility Management Measures.....   | 39        |
| Task 5.7 Development of Fiscal Measures .....  | 40        |
| Task 5.8 Mobility Improvement Measures and NUTP Objectives .....                                   | 40        |
| <b>Task 6: Preparation of the Implementation Program .....</b>                                     | <b>41</b> |
| Task 6.1 Preparation of Implementation Programs.....   | 41        |
| Task 6.2 Identification and Prioritization of Projects.....  | 41        |
| Task 6.3 Funding of Projects .....   | 42        |
| Task 6.4 Monitoring of CMP Implementation .....  | 43        |



|  |     |
|--|-----|
| <b>Section III: Methodology for Small Cities</b> .....                                   | 45  |
| <b>Section IV: ANNEXURES</b> .....   | 47  |
| <b>Annexure 1.</b> Sample Survey Forms .....   | 47  |
| <b>Annexure 2.</b> Stakeholder Consultation .....  | 81  |
| <b>Annexure 3.</b> List of NUIS Scheme Towns .....                                       | 85  |
| <b>Annexure 4.</b> Data Collection Approach – Methodology and Sources .....              | 89  |
| <b>Annexure 5.</b> Four-Step Modelling .....   | 94  |
| <b>Annexure 6.</b> Emission Factors for Vehicle Fleets under Alternative Scenarios.....  | 99  |
| <b>Annexure 7.</b> Sample TOR for Appointment of Consultant for Preparation of CMP ..... | 103 |
| <b>Annexure 8.</b> Sample Work Schedule for Preparation of a CMP for a city .....        | 111 |
| <b>Annexure 9.</b> Sample Table of Contents of CMP Document.....                         | 112 |
| <b>Annexure 10.</b> Self-Appraisal Checklist to be filled by the consultant/client.....  | 114 |
| <b>Annexure 11.</b> Indicative Checklist for Evaluating CMPs .....                       | 120 |
| <b>Annexure 12.</b> List of Maps to be Prepared.....                                     | 122 |
| <b>Annexure 13.</b> Example of cross-classification method.....                          | 123 |

## List of Tables

---

|   |    |
|---|----|
| Table 1: Illustrative Comparison of Major Tasks of CMPs and other Existing Plans..... | 4  |
| Table 2: Suggested Planning Area for Preparing a CMP Based on Population Size.....    | 7  |
| Table 3: Indicative Time for Preparing the CMP .....                                  | 8  |
| Table 4: City Profile.....  | 9  |
| Table 5: Existing Transport Systems.....  | 12 |
| Table 6: Energy Balance.....  | 15 |
| Table 7: Vehicle Inventory .....  | 15 |
| Table 8: Data related to Emissions and Environment .....                              | 15 |
| Table 9: Surveys to be conducted to incorporate SLB .....                             | 16 |
| Table 10: Indicators to be Measured for Existing and Future Scenarios.....            | 17 |
| Table 11: Vehicle Occupancy (Sample) .....  | 27 |
| Table 12: Vehicles: VKTs and Fuel Mix (Sample) .....                                  | 27 |
| Table 13: CO2 Emission Coefficients for Different Fossil Fuels .....                  | 28 |
| Table 14: Emission of PM 2.5.....   | 28 |



|   |    |
|---|----|
| Table 15: Differences in Four-Step Models for Alternative Scenarios.....      | 34 |
| Table 16: Desirable Modal Split for Indian Cities (as % of Total Trips) ..... | 36 |
| Table 17: TDM Measures Varying from Push and Pull Factors .....               | 40 |
| Table 18: Tasks to be followed for Small Cities .....                         | 46 |

## List of Figures

---

|  |    |
|--|----|
| Figure 1: Fuel Mix for the BAU Scenario .....  | 24 |
| Figure 2: Fuel Economy Improvement in Cars .....   | 24 |
| Figure 3: CO2 Intensity of Electricity from Grid .....   | 25 |
| Figure 4: Overall Modelling Framework for CMP .....  | 26 |
| Figure 5: Air Pollutant Concentrations Map, PM10 for Udaipur Using SIM air Model .....         | 29 |
| Figure 6: Four Broad Strategies and Accompanying Policies Used for Sustainable Scenarios ..... | 31 |
| Figure 7: Fuel Mix for Transport in Sustainable Low Carbon Scenario .....                      | 35 |
| Figure 8: Fiscal Dependence of ULBs.....   | 42 |



# Abbreviations

---

## Abbreviations and Acronyms

|                 |  |
|-----------------|--|
| ADB             | Asian Development Bank                           |
| BAU             | Business as Usual                                |
| BOO             | Build Own Operate                                |
| BOOT            | Build Own Operate Transfer                       |
| BOT             | Build Operate Transfer                           |
| BPL             | Below Poverty Line                               |
| BRT             | Bus Rapid Transit                                |
| BT              | Build Transfer                                   |
| BTO             | Build Transfer Operate                           |
| CBD             | Central Business District                        |
| CDM             | Clean Development Mechanism                      |
| CDP             | City Development Plan                            |
| CEA             | Central Electricity Authority                    |
| CEF             | Composite Environment Fee                        |
| CEPT            | Centre for Environmental Planning and Technology |
| CMP             | Comprehensive Mobility Plan                      |
| CNG             | Compressed Natural Gas                           |
| CO              | Carbon Oxide                                     |
| CO <sub>2</sub> | Carbon Dioxide                                   |
| CSOs            | Civil Society Organisations                      |
| CTTS            | Comprehensive Traffic and Transportation Studies |
| DBFO / M        | Design Build Finance Operate / Maintain          |
| DBM             | Design Build Maintain                            |
| DBOM            | Design Build Operate Maintain                    |
| DMIC            | Delhi Mumbai Industrial Corridor                 |
| DP              | Development Plan                                 |
| DPR             | Detailed Project Report                          |
| EB              | Enumeration Block                                |
| EPCA            | Environment Pollution Control Authority          |



|        |   |
|--------|---|
| FAQs   | Frequently Asked Questions                      |
| FAR    | Floor Area Ratio                                |
| FSI    | Floor Space index                               |
| GHG    | Green House Gases                               |
| GIS    | Geographic Information System                   |
| HC     | Hydrocarbon                                     |
| HH     | Household                                       |
| HSD    | High Speed Diesel                               |
| HUDCO  | Housing and Urban Development Corporation       |
| IDFC   | Infrastructure Development Finance Company      |
| ILFS   | Infrastructure Leasing and Financial Services   |
| IPCC   | Inter-governmental Panel on Climate Change      |
| ITS    | Intelligent Transport System                    |
| IUT    | Institute of Urban Transport (India)            |
| JICA   | Japan International Cooperation Agency          |
| JnNURM | Jawaharlal Nehru National Urban Renewal Mission |
| LCMP   | Low-Carbon Comprehensive Mobility Plan          |
| LCS    | Low Carbon Scenario                             |
| LCV    | Light Commercial Vehicle                        |
| LPG    | Liquefied Petroleum Gas                         |
| LRT    | Light Rail Transit                              |
| MFA    | Multilateral Funding Agency                     |
| MLA    | Member of legislative Assembly                  |
| MoUD   | Ministry of Urban Development                   |
| MP     | Member of Parliament                            |
| MRT    | Mass Rapid Transportation                       |
| Mtoe   | Million Tonne of Oil Equivalent                 |
| MTW    | Motorised Two / Three Wheeler                   |
| NAMA   | Nationally Appropriate Mitigation Actions       |
| NAPCC  | National Action Plan on Climate Change          |
| NGOs   | Non Governmental Organisations                  |
| NHAI   | National Highway Authority of India             |
| NMT    | Non-Motorised Transport                         |
| NOx    | Nitrogen Oxide                                  |
| NSSO   | National Sample Survey Organisation             |
| NUIS   | National Urban Information System               |
| NUTP   | National Urban Transport Policy                 |
| PBS    | Public Bicycle Sharing                          |
| PM     | Particulate Matter                              |
| PPP    | Public Private Partnership                      |



|         |  |
|---------|--|
| PT      | Public Transport   |
| PUC     | Pollution Under Control  |
| ROW     | Right of Way   |
| RTA     | Regional Transport Authority                                       |
| SC      | Scheduled Caste  |
| SLB     | Service Level Benchmarks   |
| SOx     | Sulphur Oxide  |
| SUV     | Sports Utility Vehicle   |
| TAZ     | Traffic Analysis Zone  |
| TDM     | Travel Demand Management   |
| TERI    | The Energy and Research Institute                                  |
| TOD     | Transit Oriented Development                                       |
| UIDSSMT | Urban Infrastructure Development Scheme for Small and Medium Towns |
| ULBs    | Urban Local Bodies   |
| UMTA    | Unified Metropolitan Transport Authority                           |
| UNEP    | United Nations Environment Programme                               |
| UNFCCC  | United Nations Framework Convention on Climate Change              |
| UT      | Urban Transport  |
| UTF     | Urban Transport Fund   |



## Section I:

# Introduction

---

## Background

Cities are rapidly becoming the engines of economic growth all over the developing world. In India, though only about 30% of the national population resides in urban areas, they generate over 60% of the GDP. It is also expected that cities will propel the future growth of the country. It is, therefore, essential to ensure that these urban centres are well equipped in terms of infrastructure, if India is to continue on its growth trajectory.

It is in this context that the Government of India has decided to promote 100 “Smart Cities” in the country. These will be an initial set of pilots, with the ultimate objective of making all our cities smart cities. Urban Mobility or the ease of being able to move from one place to another is at the core of a “Smart City”. A highly efficient transport system, which offers easy access to jobs, education, healthcare and other needs, is essential. To ensure mobility for all, cities need to develop a comprehensive urban transport strategy. Under the present scenario, urban transport projects are prepared and implemented in a piecemeal manner and generally not integrated with land use pattern. Some cities do prepare urban transport master plan by conducting traffic and transportation studies, but such plans mainly focus on vehicle movement and do not pay enough attention to the mobility of people and goods. The major emphasis in these plans remains on extensive infrastructure development such as road network, flyovers, improvement of road geometry, regulatory measures etc. The mobility of people as a whole is not addressed appropriately.

The concept of Comprehensive Mobility Plan (CMP) is to have a long-term vision for desirable accessibility and mobility pattern for people and goods in the urban agglomeration. It focuses on the mobility of people to address urban transport problems and promote better use of existing infrastructure (i.e., improvement of public transport, pedestrian and NMT facilities). which as such leads to the integration of land use and transport development and is essential to building smart cities.

## What is a CMP?

CMP is a vision statement of the direction in which Urban Transport in the city should grow. It should cover all elements of Urban Transport under an integrated planning process.



## Need for Revision of CMP, 2008

The toolkit for preparation of CMP was first prepared by MoUD in association with ADB in August 2008. The focus of the toolkit was on the following:

1. To optimize the “mobility pattern of people and goods” rather than of vehicles
2. To focus on the improvement and promotion of public transport, NMVs and pedestrians, as important transport modes in Indian cities
3. To provide a recognized and effective platform for integrating land use and transport planning
4. To focus on the optimization of goods movement

However, to address the various mobility aspects of Smart Cities and the growing concerns of social and environmental sustainability of cities, a need was felt to review the existing guidelines and provide new guidelines for cities to plan and meet the growing challenges of overall sustainability.

The revised toolkit would ensure the following:

- A low-carbon mobility growth scenario for the city
- Equity to all sections of the society including urban poor and differently abled
- Service level benchmarks incorporation

## Vision of a CMP

The CMP is a long-term vision for desirable accessibility and mobility pattern for people and goods in the city to provide, safe, secure, efficient, reliable and seamless connectivity that supports and enhances economic, social and environmental sustainability.

## Scope of CMP

The preparation of CMP includes the following steps:

- a) Understand the present travel characteristics and forecast travel demand for the planning horizon.
- b) Estimate emissions from urban transport based on the travel demand and technological choices.
- c) Integrate transport options with land use structure and develop alternative scenarios for sustainable transport.
- d) Work out the mobility plan which is economically, socially, environmentally and technologically sustainable and be an integral part of development plans / master plans.
- e) Suggest an implementation programme for a successful execution of the selected interventions.



## Surveys for CMP Preparation

For the preparation of Comprehensive Mobility Plan, the required information will be collected and compiled through primary surveys and secondary sources as per the survey formats listed in Section IV (Annexure 1). It provides a comprehensive list of formats required for all cities of population greater than 1 lakh, however for smaller cities some of the data may not be needed

## Main Features of CMP

The main features of CMP are the following:

- a) Prioritise mobility for all socio economic groups and genders.
- b) Give adequate attention to sustainable modes of transport (i.e., public transport, pedestrians and non-motorised).
- c) Provide a recognised and effective platform for integrating land use and transport planning.
- d) Integrate impacts of transport on local air quality, emissions, safety and social aspects.
- e) Focus on the optimisation of goods transport.

## Key Outcomes of a CMP

The CMP should lead to the following outcomes in the long term:

- a) Improvement in mobility for all socio-economic groups and genders
- b) Improvement in air quality of Sustainable Urban Transport Scenario with reference to the BAU scenario
- c) Improvement in safety and security for pedestrians, NMT and liveability in the city
- d) Increase in sustainable transport mode share and a decrease in private motor vehicle use
- e) Achievement of desirable indicators and benchmarks
- f) Integral part of Master Plan

## Relationship Between a CMP and Other Existing Plans

There are a few important plans and studies that need to be referred to when a CMP is prepared. For example: City Development Plans (CDPs), Master Plans and Comprehensive Traffic & Transportation Studies (CTTS) if available. A comparison of these plans and studies with the CMP is summarized in Table 1.



**Table 1:** Illustrative Comparison of Major Tasks of CMPs and Other Existing Plans

|   | CDP | Master plan | CTTS | CMP (2008) | Revised CMP |
|---|-----|-------------|------|------------|-------------|
| Review of existing transport system                   | ✓   |             | ✓    | ✓          | ✓           |
| Transport demand survey                               |     |             | ✓    | ✓          | ✓           |
| Review of land use plan                               |     | ✓           | ✓    | ✓          | ✓           |
| Analysis of urban transport situations                |     |             | ✓    | ✓          | ✓           |
| Preparation of future land use scenario               |     | ✓           |      | ✓          | ✓           |
| Future transport network scenario                     |     |             | ✓    | ✓          | ✓           |
| Future technological scenarios                        |     |             |      |            | ✓           |
| Transport demand forecast model                       |     |             | ✓    | ✓          | ✓           |
| Model impacts on all sections of society and modes    |     |             |      |            | ✓           |
| Network evaluation                                    |     |             |      | ✓          | ✓           |
| Model CO <sub>2</sub> emissions and air pollutants    |     |             |      |            | ✓           |
| Impact analysis of scenarios on measurable indicators |     |             |      |            | ✓           |
| Preparation of mobility framework                     |     |             |      | ✓          | ✓           |
| Formulation of urban transport measures               | ✓   | ✓           | ✓    | ✓          | ✓           |
| Social and environmental impact assessment            |     |             |      | ✓          | ✓           |
| Institutional scheme for project implementation       |     |             | ✓    | ✓          | ✓           |
| Preparation of implementation programs                | ✓   |             | ✓    | ✓          | ✓           |
| Stakeholder consultation                              | ✓   | ✓           | ✓    | ✓          | ✓           |
| Periodical update and maintenance                     |     | ✓           |      | ✓          | ✓           |

### Relationship with CDP

A City Development Plan (CDP) is a broad framework that identifies urban infrastructure requirements in various sectors, such as water supply, solid waste management, storm water drainage, sewerage, etc. CDPs rarely adopt a scientific approach to assess transportation needs of the city and do not include a clear strategy for long-term urban transport development. However, they provide valuable information regarding the existing and future development of the urban area, which are essential while planning for the horizon year.

### Relationship with the Master Plan

A Master Plan (or Development Plan) is a statutory document for guiding and regulating urban development. It defines the future area for urbanisation, and addresses planning issues for various sectors. The section on transport in the plan contains development measures such as road network (arterials, collectors, and distributors etc.), parking facilities and mass rapid transit systems. A master plan, wherever available, should serve as an input to the CMP. In this process, the CMP reviews the future land use patterns in the master plan from a mobility





optimisation point of view and selects a preferred pattern of land use / transport integration as necessary. If the recommendation by the CMP on urban growth pattern differs from the one in the master plan, the CMP recommendation may be reflected in a future version of the master plan. This would also ensure integrated planning which is the key ingredient for smart cities, For cities where master plan is not available, the CMP may be used as the starting point for preparation of the master plan.

## Relationship with the CTTs

Some cities have already conducted CTTs by examining traffic and transport issues and recommending improvement measures. While CTTs focuses on vehicle flows, the CMP will concentrate on the mobility of people. CTTs does not develop scenarios as the CTTs is basically a transport sector study. However the model developed for the CTTs can be used for the further development of scenarios while preparing the CMP. Also it may provide useful strategies and future network, which are essential for developing the plan for the future..

## Frequently Asked Questions on Comprehensive Mobility Plan

### *Who should use this toolkit?*

Targeted users of this CMP toolkit include policy makers, city authorities and consultants. The toolkit provides:

1. Guidance in setting CMP visions/objectives for policy makers;
2. The structure and process of CMP development for city authorities;
3. Detailed tasks to be performed by consultants for preparation of CMP; and
4. A guidance for the policy makers and city authorities on what to expect from the consultants.

### *Who should be responsible for the preparation of CMP?*

City authorities should be responsible for the preparation of CMPs. During the process of the CMP preparation, a wider consultation with key stakeholders like the Development Authority, Municipal Corporation, ULBs, RTO, etc. is recommended to organize seminars and workshops to obtain feedback from the stakeholders.

### *Why do CMPs need to be prepared BEFORE the feasibility studies of specific projects?*

To ensure sustainable development of cities, it is essential that a city-wide macro-level plan is prepared, which identifies and prioritises projects. CMP is that macro-level plan for the city. Feasibility studies and DPRs of prioritised projects identified in the CMP will give best value for money.

### *How much detail is required in the recommended policy measures included in a CMP?*

Although a CMP serves as a visionary document, it should also provide a clear and logical methodology to achieve the objectives. As such, any project recommended in a CMP should broadly identify an implementation organisation. A further study, required for feasibility assessment and detailed design, should be performed after the CMP is approved.



### ***Do CMPs need to be updated regularly?***

Yes. Since cities are constantly changing, it is recommended that every city updates its CMP atleast once in every five years.

### **Preparing for a CMP: Where to Start?**

A Master Plan<sup>1</sup> for the city can be taken as a starting point for preparation of CMP. Land use structure and transport proposal indicated in the master plan can serve as guidance for the BAU scenario. CMP however analyses alternative land use scenarios and accordingly the required changes in the land use structure may be suggested to be incorporated in the revised version of the master plan.

## **Understanding Key CMP Tasks**

The major tasks to develop a CMP are set out below. Detailed task descriptions are given in Section II

**Task 1:** Defining Scope of the CMP

**Task 2:** Data Collection and Analysis of the Existing Urban Transport Environment

**Task 3:** Development of Business as Usual (BAU) Scenario

**Task 4:** Development of Sustainable Urban Transport Scenarios

**Task 5:** Development of Urban Mobility Plan

**Task 6:** Preparation of the Implementation Program

---

<sup>1</sup>Most of the cities have a Master Plan; if not available then any other available Development Plan can be used as a reference.

## Section II:

# Task Descriptions

---

### **TASK1: Defining the Scope of the CMP**

The first step in preparing a CMP is to define the scope of the project. The consultant must prepare an Inception Report clearly indicating the following details:

- Planning area
- Planning horizon
- Work Plan
- Vision

#### ***Planning Area***

The planning area should cover the urban agglomeration or metropolitan area or city region as identified in the master plan/regional plan. In many aspects, the master plan should be used as a base for preparing the CMP. The suggested planning area based on the city population size is given in Table 2.

**Table 2:** Suggested Planning Area for Preparing a CMP Based on Population Size

| <b>Size of City ( population in lakhs)</b> | <b>Planning Area</b>  |
|--|---|
| Metro city (> 10)                          | Metropolitan area/Region<br>(as identified by state government) |
| Large city (5 – 10)                        | Notified Planning area<br>(as indicated in the Master Plan)     |
| Other city (<5)                            | Municipal area/Urban Agglomeration                              |

A CMP must address not only city transportation needs but also the needs for regional connectivity with satellite towns and Special Economic Zones (SEZs). As such the planning area for the CMP needs to include the urban agglomeration.



### Planning Horizon

If we consider that CMP leads to investments in transport infrastructures with long-term impacts on climate change and other issues, its planning horizon should be at least 20 years. In addition, immediate (optional), short-term and medium-term target with a range of 2 (two), 5 (five) and 10 (ten) years, respectively, should be included. The CMP horizon should be aligned with the Master Plan horizon, as much as possible.

### Work Plan

The average period for preparation of CMP is estimated to be about 12 months for the study area with a population of about twenty lakh (two million). However this schedule is indicative and will vary depending on the city’s size, availability of data and time for collection of information (Table 3). A typical work schedule and time frame for preparing a CMP is shown in Annexure 8.

**Table 3:** Indicative Time for Preparing the CMP

| Size of city ( population in lakhs) | Average time for preparation (in months) |
|-------------------------------------|--|
| < 5                                 | 8  |
| 5 – 20                              | 12                                       |
| 20 – 40                             | 18                                       |
| > 40                                | 24                                       |

### Vision for the City

A vision statement for the direction of the city’s transport system should be based on the diagnosis of the current public transport, mobility, urban transport environment and the future urban growth scenario. It must be in line with the overall vision of the city’s growth indicated in the master plan.

### Consultation for Validation of CMP

CMP is a roadmap document with a long-term inclusive and integrated vision. The intent of the proposed consultation process is to validate the CMP document through discussions with stakeholders/agencies, which will play an important role during the implementation of the CMP. The stakeholders should be consulted at all stages of preparation of CMP. A note indicating the stages of consultation with various stakeholders is given in Annexure 2.

## Task 2: Data Collection and Analysis of the Existing Urban Transport and Environment

### Task 2.1 Review of the City Profile

To study the city’s present socio-economic profile and trends over a period of time, the consultant should collect data from secondary sources on land area, administrative boundaries, regional linkages, demography and socio-economic characteristics. Table 4 summarises the data requirements for the city profile in CMP.



Table 4: City Profile

| Data required       | Description  | Source for Primary Data  | Data level |
|---------------------|--|--|------------|
| Location            | Geographical location  | Master plans of the city and region if available/ CDP  | City wide  |
| Land area           | Total land area  | Master plan of the city and region   | City wide  |
|                     | Growth pattern   | Master plan of the city and region   | City wide  |
|                     | Identification of notified areas                                     | Master plan of the city and region   | City wide  |
| Regional linkages   | Road & Rail Network  | Master plan/CDP  | City wide  |
| Demography          | Population growth trends by census wards or enumeration blocks       | Census   | City wide  |
|                     | Number and size of house hold  | Census   | City wide  |
|                     | Age-sex pyramid  | Census   | City wide  |
| Socio-economic data | Population by income / expenditure on transport at TAZ or ward level | If city level GIS data available or enumeration block data of the census and primary surveys | City wide  |
|                     | Vehicle ownership (including bicycles) by social group               | RTO, other local agencies / primary surveys  | City wide  |

## Task 2.2 Delineation of Traffic Analysis Zones

For the purpose of analysis and development of travel demand forecasting model, the study area is required to be subdivided into smaller areas known as Traffic Analysis Zones (TAZs) or Zones as they are commonly referred to. Zones are an aggregation of various units such as households work place, shopping area, and other activities, which cannot otherwise be represented individually. TAZs which are located inside the planning area, as defined in Task 1, are called internal zones. The areas, outside the study area are aggregated into larger zones along the major directions of travel and are termed as external zones. These zones help analyse trip interactions between internal-internal, internal-external, external-external and external-internal.

### The Basis of Zoning

TAZs are delineated taking into account various factors such as administrative boundaries, physical barriers like water bodies, railway lines, highways and homogeneous land uses.

There are no standards to delineate the TAZ boundaries but the following criteria can help in guiding the delineation of TAZ boundaries:

1. **Administrative boundaries:** TAZ boundaries should follow administrative boundaries, including those of municipal corporations, villages, investment areas, and so on. Within these boundaries, TAZs should follow census ward boundaries. This is to ensure availability of secondary information like population, land use and other socio-economic information which can be useful to start with. In case a master plan is available, the zones or sub-zones of the city as indicated in the plan may be used.



2. **Physical barriers** in the city like rivers, lakes, canals, railway lines may be considered for delineating TAZ.
3. **Road network and public transport (PT) network in the study area:** The zone size would also get affected by the road and PT network in the study area.
4. **Homogeneity in land use:** This is another important consideration. For example, major centres like industrial areas or major residential pockets should be considered as a single zone.
5. **Special traffic generators** at regional / city level like railway station, sports complexes / major freight centres etc. might be considered as separate zones.

### Zone sizes

Within the developed area of the parent city, the zone sizes should be as uniform as possible. If some zones are much bigger than the others, a significant number of trips will be made within the zone (intra-zonal trips) that will not reflect on the network.

As a general guide, a population of 1,000 – 3,000 is optimum for a small area and a population of 5,000 – 10,000 may be optimum for a large area<sup>2</sup>. If the study area includes outskirts and peripheral areas around the city which are not fully developed, these may be merged with the existing administrative zones at which socio-economic, census, etc data is available.

## Task 2.3 Review of Land Use Pattern and Population Density

Once the zones for the study area have been defined, the next step is to collect data in which, slums should also be considered as a part of residential land use and not a separate land use. And also residential land use zones should have income groups marked as well. This can be done by using data on household assets and the type of building (available from property tax data/ household survey<sup>3</sup>) as a proxy. If data on household assets is not available then the disaggregation of residential land use into income groups can also be done by using per capita floor area as a proxy, which can be calculated using the formula given below:

$$\text{per capita floor area} = \frac{\text{household area}}{(\text{no. of members in the household})}$$

Housing characteristics can be a useful indicator of income. The per capita floor space<sup>4</sup> is also an indicator of a low-income household.

### Land Use Data

CDP or master plans are the prime data sources for reviewing existing land-use patterns. However, there are well-documented concerns about poor enforcement of development control in India<sup>5</sup>, and development plans

<sup>2</sup>Source: 1. Traffic Engineering & Transport Planning, Dr L.R. Kadiyali

2. A Recommended Approach to Delineating Traffic Analysis Zones in Florida, Cambridge Systematics, Inc. & AECOM Consultant

<sup>3</sup>Refer Task 2-5

<sup>4</sup>The per capita floor area, derived by dividing total floor area of the dwelling unit by household size (members).

<sup>5</sup>See Pucher, J., et al. (2005). "Urban transport crisis in India." *Transport Policy* 12(3): 185-198.; Dimitriou, H. T. (2006). "Towards a generic sustainable urban transport strategy for middle-sized cities in Asia: Lessons from Ningbo, Kanpur and Solo." *Habitat International* 30(4): 1082-1099., Alan, T. (1992). "Urban planning in the developing world: Lessons from experience." *Ibid.* 16(2): 113-126.,



and master plans often do not represent actual development on the ground<sup>6</sup>. An alternative source for land use information collected by the National Urban Information System (NUIS)<sup>7</sup> Scheme may therefore be used. A list of 152 cities for which GIS data is available under NUIS is enclosed in Annexure 3.

In cities where NUIS data is not available, CDPs or Master Plans can be used in conjunction with property tax data, which is available from the respective municipal corporation. The pattern of land use needs to be analysed, for land/floor area consumption per land use in each TAZ. This indicator is represented as a percentage of land under each land use. The ratio of residential land use and employment-generating land use has been found to have a significant influence on travel distance and choice of walking, bicycle and public transport modes. This is generally measured as a ratio of the number of jobs to the number of household in each zone. Similarly, an indicator that influences the distance individuals travel for obligatory activities like shopping, recreation, etc. has been included as a question in the household survey (Annexure1 and 4).

### Analysing Density

In addition to residential densities, job densities must also be studied and analysed. Ward-level decadal data on population is available from the Census of India and can be used for the analysis. To estimate the **number of persons/job per unit area**, the following equation may be used:

$$\text{No. of persons/job per unit area} = \frac{R_j}{AR_j \times AJ_j}$$

Where,

$R_j$  = no of residents in a zone

$AR_j$  = area under residential purpose landuse in the zone

$AJ_j$  = no.of jobs in the zone to the area under land uses that generate these jobs respectively

Another important parameter to be analysed is the **Floor space used per activity per unit area**, which is estimated as:

$$\text{Floor space used per activity per unit area} = \text{number of floors} \times \text{land use (activity)}$$

Using floor space per activity as an indicator will help compare the BAU urban development projection with sustainable urban policy scenarios. For example, comparing land use scenarios when a different Floor Space Index<sup>8</sup> (F.S.I) norm is introduced may reveal changes in either the per-activity consumption of floor space or in the sheer number of activities available in the same amount of land as before.

<sup>6</sup>See Munshi, T. (2013). Built form , Travel Behaviour and Low Carbon Development in Ahmedabad, India. Faculty of ITC. Enschede, the Netherlands, University of Twente. PhD.

<sup>7</sup>Available online at <http://urbanindia.nic.in/programme/lsg/nuis.htm> ).

<sup>8</sup>Ratio of built-up area to land area



## Task 2.4 Review of the Existing Transport Systems

A review of existing transport infrastructure and facilities needs to be done for all transport modes including public transport (private and public), private vehicles, walking, cycling, cycle rickshaw, auto rickshaw, shared auto rickshaw, etc. For this purpose, a number of surveys need to be conducted. The data collected must be visually represented, such as on maps, to avoid any ambiguity. The information that needs to be collected is given in Table 5. The maps that need to be prepared are given in Annexure 11.

**Table 5: Existing Transport Systems**

| Data required   |   | Data level | Source   |
|---|---|------------|--|
| <b>1) Road Network Inventory</b>  |   |            |  |
| Infrastructure for pedestrians  | Footpath (Survey format 1b)   | Sample     | Primary Survey   |
|   | Intersections (Survey format 2)   | Sample     | Primary Survey   |
|   | Access (Survey format 1b)   |            |  |
| Infrastructure for bicycle and cycle rickshaws  | Lanes (Survey format 1c)  | Sample     | Primary Survey   |
|   | Intersection treatment (Survey format 2)                                      | Sample     | Primary Survey   |
| Public transport (bus) - In absence of bus services, a similar analysis can also be made of the shared rickshaw services. | Infrastructure (Survey format 7c)   | Sample     | Primary Survey   |
|   | Bus stop (Survey format 7a & b)   | Sample     | Primary Survey   |
| Road Network Inventory  | Road infrastructure (Survey format 1a)  | Sample     | Primary Survey   |
|   | Intersections (Survey format 2)   | Sample     | Primary Survey   |
|   | Parking (Survey format 4)   | Sample     | Primary Survey   |
| <b>2) Public Transport System – City Bus, and also for other mass transit systems if any (Metro, LRT, etc)</b>            |   |            |  |
| Fleet usage detail  | Number of buses by type of bus (standard, mini, low floor), fuel used and age | Citywide   | ULB & RTO  |
|   | Fleet utilization rate  | Citywide   | State Road Transport Corporation (SRTC) report & city's bus company if any |
|   | Vehicular kilometers  | Citywide   | SRTC report  |
|   | Average kilometers per bus per day  | Citywide   | SRTC report  |
|   | Percentage occupancy- peak hour and average                                   | Citywide   | SRTC report & city's bus company if any                                    |
|   | Total passengers per day  | Citywide   | SRTC report  |





| Data required   |   | Data level | Source                                    |
|---|---|------------|---|
| Route detail  | Route inventory along with bus stops  | Citywide   | SRTC report & city's bus company if any   |
|   | Headway on different routes   | Sample     | Primary Survey                            |
|   | Average route speed   |            |   |
|   | Service reliability   |            |   |
| Cost and fare   | Operation cost per km   | Citywide   | SRTC report & city's bus company if any   |
|   | Tax levied  |            |   |
|   | Fare structure & Mobility card (Pass)   |            |   |
|   | Revenue per km  |            |   |
|   | Profit/loss   |            |   |
| <b>3) Para-Transit System</b> - This is not an exhaustive list of options and can be extended to include water transport, ropeways, etc |   |            |   |
| Fleet usage detail  | Type of ownership   | Citywide   | RTO, para-transit workers' union & survey |
|   | Number of para-transit by type (shared and personal autos), fuel used and age |            |   |
|   | Vehicular kilometres  |            |   |
| Route detail  | Route inventory for shared auto   | Citywide   | RTO                                       |
|   | Average waiting time for auto, cycle rickshaw and shared auto                 | Sample     | para-transit workers' union               |
| Cost and fare   | Operation cost per km   | Citywide   | para-transit workers' union               |
|   | Tax levied  |            |   |
|   | Fare structure  |            |   |
|   | Revenue per km  |            |   |
|   | Profit/loss   |            |   |
| <b>4) Freight Transport</b>   |   |            |   |
| Freight vehicle Survey (Survey Format 9)  | Origin and destination points   | Sample     | Primary Surveys                           |
|   | Parking areas for freight vehicles and cost                                   |            |   |
|   | Vehicle typology  |            |   |
| <b>5) Traffic Conditions on Roads (TVC, delay and queue length)</b>   |   |            |   |
| Traffic count   | Screen line by modes  | Sample     | Primary Surveys                           |
|   | At intersection by modes  |            |   |
| Delay and queue length  | Delay by mode   |            |   |
|   | Travel speed by mode  |            |   |
| <b>6) Traffic Safety</b>  |   |            |   |
| Number of victim involved in traffic fatalities and location  | By victim mode  | City level | Traffic police FIR                        |
|   | By impacting vehicle  |            |   |

The data collected and the model developed should be publicly shared on the Knowledge Management Centre, IUT and with the cities.



Key locations for data verification must be identified through a process that must be communicated in the CMP to capture a wide range of possible origins and destinations. However, the number of points and counts will vary depending on the travel characteristics and demographics of the study area. Locations must be balanced between those immediately adjacent to city centres/business districts and those on the urban periphery.

## Task 2.5 Study of Existing Travel Behaviour

Two important considerations should be taken into account while collecting data on travel patterns. The collected data should cover the travel behaviour of all individuals within a household, and the data should be segregated by mode and trip purpose. The household survey is designed to capture access time of the trip, trip purpose, the address of the trip starting and ending points, mode of travel for each stage of the journey<sup>9</sup> and to represent people's perceptions towards different modes of transport in terms of time, cost, comfort, safety and security. The questionnaire is divided into two parts:

1. General or household questionnaire
2. Individual questionnaire

Details of the household survey are given at Annexure 1 (Survey Format 11).

## Task 2.6 Review of Energy and Environment

Energy consideration is one of the key concerns of a "Smart City". Quantifying energy consumption for transport is important for estimating the CO<sub>2</sub> and local air pollution emissions from transport-related activities. To create a complete picture, both top-down and bottom-up approaches for estimating energy consumptions are required. The top-down approach relies on information provided by energy suppliers such as oil companies, electricity department, etc. (generally a few) and the bottom-up approach relies on a primary survey of vehicle users to assess the energy consumption of different vehicle categories, which are then combined with the in-use vehicle population to provide an estimate for total energy use within a city.

### Energy Balance

Energy balances are a way of representing aggregate energy flows from energy suppliers to energy consumers and are used as an accounting tool for estimating energy-related emissions. In general, energy balances cover all fuels; however since the focus here is on transport, only diesel, petrol, LPG, CNG and electricity will be covered. A simplified energy balance format for energy consumption at the city level within the transport sector is provided in Survey format 12.

---

<sup>9</sup> What is a "trip" – It is a journey carried out for a unique purpose. e.g. "Shabari walks from her house to a roadside stand to buy some fruit, then boards a bus, then transfers to a suburban train. Finally she takes a rickshaw to her daughter's school. She and her daughter take a ride with a friend in her car to a coffee shop." She performs 5 trips in total. The different modes which she uses for each trip are walk, bus, train, rickshaw, car.



**Table 6:** Energy Balance

| Data required                                  | Description   | Data Source                       | Data level |
|--|---|-----------------------------------|------------|
| Consumption of fossil fuels for transportation | Diesel, petrol, CNG, LPG consumption within the city on the basis of sales made by retail outlets and company operated depots / outlets | Oil companies                     | City       |
| Consumption of electricity for transportation  | Electricity consumed for metro /trams / sub urban trains  | Railways & mass transit operators | City       |

**Vehicles: Fuel Types and Efficiency**

The vehicle stock can be obtained from the vehicle registration records (Survey format 13). However, these records include no details regarding how many of these vehicles are actually in use, how much they travel on an average in a year, what fuel they use, or what their fuel economy is. These details need to be obtained by conducting a primary survey of vehicles at petrol pumps (Survey format 14) and refer to Annexure 4 for a sampling approach.

**Table 7:** Vehicle Inventory

| Data required                         | Description  | Data Source                       | Data level |
|---------------------------------------|--|-----------------------------------|------------|
| Vehicle Inventory (Survey format 13)  | Stock of vehicles by year of manufacture (passenger and goods)   | Road transport authority & survey | City       |
| Vehicle efficiency (Survey format 14) | Efficiency characteristics of vehicle categories with vintage (mileage, average vehicle kms travelled) | Survey at petrol pumps            | Sample     |

**Ambient Air Quality**

The data related to ambient air quality is helpful for understanding the impact of transport on air pollution. In some cities, the pollution control department has installed measurement instruments in a few places within the city. However, data on ambient air quality is not available for all cities, and in such cases the data of cities of similar characteristics can be used. The data collected for air quality is required for calibration of air quality models<sup>10</sup>.

**Table 8:** Data related to Emissions and Environment

| Data required      | Description  | Data Source              | Data level             |
|--------------------|--|--------------------------|------------------------|
| Air quality levels | NOx, CO, SOx, Particulate Matter PM10, 2.5 concentration by location | Pollution control boards | Sampling stations only |

<sup>10</sup> More details on air quality models are available from Urban Emissions website <http://www.urbanemissions.info/>



## Task 2.7 Service Level Benchmarks

Infrastructural data have to be collected other than the data listed in Table 4, 5&8. This data should then be compared with the service-level benchmarks to understand the level of service provided to the citizen of certain specified parameters. There will be a regular check on the level of service provided, so that the level of service can be improved accordingly. The data to be collected for service-level benchmarking are given in Table 9.

**Table 9:** Surveys to be Conducted to Incorporate SLB

| S. No. | Benchmarks  | Area to be covered  | Primary Survey Required  |
|--------|---|---|--|
| 1.     | Public Transport facilities                                     | Key public transport corridors along the city                                       | <ul style="list-style-type: none"> <li>● Boarding Alighting at major bus stops of identified routes</li> <li>● Passenger count inside the bus on identified routes</li> </ul>  |
| 2.     | Pedestrian Infrastructure facilities                            | Arterial / sub arterial roads / Key Public transport corridors along the city       | <ul style="list-style-type: none"> <li>● Collect phasing plan of a signalised intersections in a city</li> <li>● Measurement of intensity of street light by lux meter</li> <li>● Footpath length having minimum width of 1.2 m or more</li> </ul> |
| 3.     | Non-Motorised Transport (NMT) facilities                        | Arterial roads / sub arterial roads / Key Public transport corridors along the city | <ul style="list-style-type: none"> <li>● Dedicated NMV track having minimum width of 1.5m or more</li> <li>● Measurement of parking area on dedicated Cycle track Signalized Intersection count</li> </ul>   |
| 4.     | Level of Usage of Intelligent Transport System (ITS) facilities | City Municipal area / Planning boundary   | <ul style="list-style-type: none"> <li>● Count of signalized intersections, bus stops, terminals, metro stations etc</li> </ul>  |
| 5.     | Travel speed (motorised and mass transit) along major corridors | Arterial roads / sub arterial roads / Key Public transport corridors along the city | <ul style="list-style-type: none"> <li>● Speed and Delay</li> <li>● Journey time of bus at identified bus route</li> </ul>   |
| 6.     | Availability of Parking spaces                                  | Arterial roads / Sub arterial roads / Key Public transport corridors along the city | <ul style="list-style-type: none"> <li>● Parking survey</li> </ul>   |
| 7.     | Road Safety   | City Municipal area / Planning boundary   | Nil  |
| 8.     | Pollution levels  | City Municipal area / Planning boundary   | Nil  |



| S. No. | Benchmarks  | Area to be covered                      | Primary Survey Required  |
|--------|---|---|--|
| 9.     | Integrated Land Use Transport System                | City Municipal area / Planning boundary | <ul style="list-style-type: none"> <li>● Land use observation survey along transit corridors</li> <li>● Total length of roads having ROW 9m and above</li> <li>● Total length of roads having exclusive BRT/Metro/LRT</li> </ul> |
| 10.    | Financial Sustainability of Public Transport by bus | ULB / Parastatal agency                 | Nil  |

The survey locations and detail data analysis of each survey should be captured in the report so as to maintain consistency in measurement or survey locations over time.

### Task 2.8 Analysis and Indicators (Comparison with Benchmarks)

Indicators provide an easy way to communicate a city’s transport status, or to make comparisons across alternative scenarios. The indicators for transport at the city level<sup>11</sup> (see Table 10) can be broadly divided into i) indicators for mobility and accessibility; ii) infrastructure and land use; iii) safety and security; iv) environmental impacts; and v) economic (Response indicators). Most of the indicators can also be directly linked to the Service-Level Benchmarks<sup>12</sup>.

The details of the selected indicators (relevance) have been furnished in reports on city-level indicators. However, some of the indicators, specifically related to investment trends and impact on affordability, might be difficult to use for business as usual (BAU) and alternate scenarios (Table 10).

**Table 10:** Indicators to be Measured for Existing and Future Scenarios

| Indicator type                    | Description   | Measurement / data source   | Existing | Future scenarios |
|-----------------------------------|---|---|----------|------------------|
| <b>Mobility and Accessibility</b> |   |   |          |                  |
| Modal shares                      | Modal shares by trip purpose i.e. work, education, health and others <sup>13</sup>    | Household surveys and some relevant data may also be available in City Traffic and Transport Study (CTTS) and Comprehensive Mobility Plan (CMP) | ✓        | ✓                |
|                                   | Modal Shares by mode i.e., 2wheeler, car, bicycle, bus, Auto, Shared Auto, Metro, Etc |   |          |                  |
|                                   | Modal shares by social groups i.e. by income, women headed household                  | National Sample Survey Organisation (NSSO) data and household surveys   | ✓        | ✓                |

<sup>13</sup> The indicator classification is based on city level indicators developed for the cities in UNEP project for Low Carbon Comprehensive Mobility Plan. Available at [http://www.unep.org/transport/lowcarbon/newsletter/pdf/ANNEXURE%20%20City%20level%20Indicators\\_%204oct.pdf](http://www.unep.org/transport/lowcarbon/newsletter/pdf/ANNEXURE%20%20City%20level%20Indicators_%204oct.pdf)

<sup>14</sup> Service-Level Benchmarks for Urban Transport Available at <http://jnnurm.nic.in/wp-content/uploads/2010/12/SLB-Urban-Transport.pdf>

<sup>15</sup> Needs to be measured for all modes including pedestrians, bicycles, public transport (bus formal), public transport (tempos), para-transit (cycle rickshaw), para-transit (auto), motorized two wheeler and cars



| Indicator type                                      | Description  | Measurement / data source  | Existing | Future scenarios |
|---|--|--|----------|------------------|
| Travel time   | Average travel time by trip purpose i.e. work, education, health and others using different modes                            | Household surveys or use validated four step model for different cities  | ✓        | ✓                |
|   | Trip purpose wise average travel time disaggregated by social groups   | Four step model to capture travel time by specific social groups for different trip purpose  | ✓        | ✓                |
| Trip length   | Average trip length (ATL) frequency distribution(for all modes including walk, cycle, bus, para-transit and private vehicle) | CMP or CTTS for specific cities or four step model   | ✓        | ✓                |
|   | Mode wise ATL disaggregated by social groups   | Household survey   | ✓        | ✓                |
|   | Trip purpose wise ATL disaggregated by social groups   | Household survey or relevant data from NSSO  | ✓        | ✓                |
| Passenger Kilometre (PKM) & Vehicle Kilometre (VKM) | Mode wise PKM & VKM Trip purpose wise PKM & VKM  | Four step model to capture travel time by specific mode for different trip purpose   |          |                  |
| <b>Infrastructure and Land use</b>                  |  |  |          |                  |
| Infrastructure quality                              | Average speed on roads of different modes  | Available in CTTS, CMP and City Development Plan (CDP) for specific roads in cities  | ✓        | ✓                |
|   | Percentage of household within 10 min walking distance of PT and para-transit stop   | Needs to be calculated based on the PT stop inventory and number of households in census records                                     | ✓        | ✓                |
|   | Average number of interchanges per PT trip   | Household surveys  | ✓        | ✓                |
|   | Accessibility of disadvantaged groups by different modes   | More specific indicators to be able to measure accessibility for disadvantaged people needs to be developed and data be collected    | ✓        | ✓                |
| Land use parameters                                 | Land use mix intensity   | Job-housing balance determined using census data available at ward or electoral block level  | ✓        | ✓                |
|   | Income level heterogeneity   | Concentration index of different income groups in a zone determined by the asset ownership or housing type data in census-households | ✓        | ✓                |
|   | Kernel density of roads, junctions and PT stop   | Requires road inventory and public transport network data in vector form   | ✓        | ✓                |



| Indicator type               | Description  | Measurement / data source   | Existing | Future scenarios |
|------------------------------|--|---|----------|------------------|
| <b>Safety and Security</b>   |  |   |          |                  |
| Safety                       | Risk exposure mode wise  | Number of fatal accidents per 100,000 users of the mode. Detailed accident data can be collected from traffic police                                      | ✓        | ✓                |
|                              | Risk imposed by modes  | Number of accidents caused by the mode on other road users per 100,000 of all the road users. Detailed accident data can be collected from traffic police | ✓        | ✓                |
|                              | Overall safety   | Number of fatal accidents per 100,000 populations. Detailed accident data can be collected from traffic police  | ✓        | ✓                |
|                              | Speed limit restrictions   | Percentage of roads having speed limit $\geq$ 50 kmph   | ✓        | ✓                |
|                              | Quality of footpath infrastructure   | Percentage of roads with $\geq$ 2m  | ✓        | ✓                |
| Security                     | Percentage of road lighted   | Data needs to be collected  | ✓        | ✓                |
|                              | Percentage of footpaths lighted  | Data needs to be collected  | ✓        | ✓                |
|                              | Percentage of people feeling safe to walk / cycle and use PT in city by gender | Specifically designed stated household surveys  |          |                  |
| <b>Environmental Impacts</b> |  |   |          |                  |
| Emissions                    | GHG emissions  | Equivalent CO2 emissions per passenger km by mode   | ✓        | ✓                |
| Depletion of land resource   | Per capita consumption of land for transport activity                          | Land use data from CDP or master plans of cities  | ✓        | ✓                |
|                              | Land consumed for different transport activities                               | Percentage of total land used in transport for different type of transport infrastructure – road, parking bus lanes, railways, etc.                       | ✓        | ✓                |
| Health hazards               | Percentage of population exposed to air pollution                              | Need to map air quality in city and mark households in the buffer area<br>Or<br>Get the relevant morbidity data from hospitals or medical authorities     | ✓        | ✓                |



| Indicator type                        | Description  | Measurement / data source                           | Existing | Future scenarios |
|---------------------------------------|--|---|----------|------------------|
| <b>Economic (response indicators)</b> |  |   |          |                  |
| Investment                            | Trend in investments for development of infrastructure for various modes | Data from city budgets across years                 | ✓        |                  |
| Cost borne by operators               | Tax burden mode wise   | Data to be collected from Regional Transport Office | ✓        |                  |
|                                       | Fuel prices at pumps by fuel type  |   | ✓        |                  |
|                                       | Other charges levied as applicable at city level disaggregated by modes  | Transport Department                                | ✓        |                  |
| Fare policy                           | Percentage of subsidies granted  | Transport Department                                | ✓        |                  |
|                                       | Percentage of population owning passes                                   | Transport Department                                | ✓        |                  |

## Task 3: Development of Business as Usual (BAU) Scenario

### Task 3.1 Framework for Scenarios

#### Background

This scenario represents the future based on the continuation of past trends and is often used as a reference point or benchmark for assessing the need for policy interventions. **The BAU scenario extrapolates existing trends and assumes no radical policy interventions for sustainable development and emission mitigation. However, it does incorporate infrastructure development and land use according to the MasterPlans** (see Task 3-2). Future transport demand is based on the preferences of different socio-economic groups in the base year. In terms of passenger transport, the BAU scenario predicts increased car ownership and higher demand for motorisation. In terms of technologies, the scenario foresees continued reliance on fossil fuel cars. With improved efficiency and a greater share of electric and hybrid cars, the share of bio-fuels and electricity is also expected to improve in the transport sector (see Task 3-5 for fuel, vehicle and electricity transitions in BAU).

#### Model Framework

Models link scenario drivers to the outcomes to be analysed. **For CMPs, the key outcomes include:**

- **Mobility and accessibility,**
- **Safety,**
- **Environment, and**
- **Energy.**





Given this wide variety of outcomes, it is obvious that a combination of models is required. A description of the model for the CMP work is provided in Task 3-4 (the transport planning model) and Task 3-6 (overall model framework and linkage between transport planning and CO<sub>2</sub> emissions and air quality model).

### Task 3.2 Socio-Economic Projections

A city's future economic transitions depend on the current economic transitions taking place across the country. It is also necessary to understand the city's role in the state and country's economic development planning goals. For example, if the proposed DMIC<sup>14</sup> includes a certain city, it would lead to more economic development than the general trend for the country as a whole, or past trends for the city. Economic transition also leads to social transitions in terms of population (local and migrant), household size, income levels and vehicle ownership.

#### *Demographic Projections*

Demographic projection includes population projections for the city along with other demographic variables like family size, agegroup, gender proportion, etc. The population projections should also consider rural-urban, rural-rural and urban-rural migration. The population for each TAZ estimated under Task 2-3 can be used as the basis.

#### *Employment Projection*

The jobs for each activity in a particular TAZ, as has been calculated under Task 2-3, can be further projected for the coming years.

#### *Industrial Growth Projection*

The employment projections are also affected by the industrial growth in the region. Industrial growth projection depends on the national and state level policies for the region and the growth trend for each of the city's existing and planned industrial sectors. The growth rates for large industrial sectors (e.g., steel, cement, chemicals, textiles) are linked to the overall economic growth projections for India. The growth projections for the 12<sup>th</sup> five-year plan are available from the Planning Commission document.<sup>15</sup>

### Task 3.3 Land Use Transitions

The objective of successful land-use development and growth models is to identify where, how much and what kinds of land use will develop. When modelling urban developments, it is necessary to consider changes from a vacant land to built-up, as well as changes in the land use itself, such as from residential to commercial. Simulation tools should be used to study these types of land use changes.

<sup>14</sup> Delhi Mumbai Industrial Corridor (DMIC) is a major infrastructure development stretching across the states of Maharashtra, Gujarat, Rajasthan, MP, Delhi, Haryana and Uttar Pradesh which will lead to high industrial growth in the corridor area.

<sup>15</sup> For 12<sup>th</sup> Five Year refer <http://planningcommission.gov.in/plans/planrel/12thplan/welcome.html>



The input requirements needed for land use simulation consist of the following:

- Existing land use type and its floor area (property tax department) and
- Floor space requirement per capita<sup>16</sup> for each land use/TAZ within the city as estimated under Task 2-3.

The land use type should be disaggregated into residential, commercial, retail, recreational, industrial, educational, religious, and other categories. Land use projections and allocations for the coming years should be done in three steps.

**Step 1** - This includes the projection of population and employment and estimating the per capita space requirements for each activity as per the equations given below.

$$FS_R = FA_R \times P_R$$

Where,

$FS_R$  = floor space requirement for residential (for various income groups)

$FA_R$  = existing per capita floor area for residential

$P_R$  = projected residential population (for various income groups<sup>17</sup>)

$$FS_E = FA_E \times P_E$$

Where,

$FS_E$  = floor space requirement for employment (for various sectors)

$FA_E$  = existing per capita floor area for employment

$P_E$  = projected employment (for various sectors)

**Step 2** - The second step involves two stages:

**Stage A**—the allocation of non-residential activities based on past trends, Master Plan provisions, as well as the availability of space

**Stage B**—the allocation of residential activity based on accessibility to jobs for each TAZ, Master Plan provision and availability of space

While allocating activities the General Development Control Regulations (GDCRs) of the city must be referred to as they define the quantum of floor space that can be developed under various land uses.

**Step 3** - The third step includes the scope of the land use transition. For example, the probability that a certain area will become completely commercial will shift the residential space to the city's outer areas in the coming years.

<sup>16</sup> The per capita floor area, derived by dividing total floor area of the dwelling unit by household size (members).

<sup>17</sup> Reference Income Groups are: Group 1 – Low Income Group – residing in kuttcha or independent houses without any assets (i.e. television or telephone) and do not own any motorized vehicle

Group 2 – Middle Income Group – residing in independent houses or apartments and own 1 motorized two wheeler (scooter/ motorbike)

Group 3 – High Income Group – residing in independent houses or apartments and own a four wheeler with other assets



Once the allocation of activities is completed, the impact of land use on transport must be analysed. When that is done, either the allocation of activities is accepted, or activity allocation process continues and the loop from land use simulation to transport impacts can be re-assessed until low carbon transport mobility goals are achieved.

### Task 3.4 Transport Demand Analysis

The demand for passenger transport can be estimated using a four-step model (see Annexure 5 for a detailed description). The four-step model is based on inputs of existing travel behaviour obtained from the household survey (Survey format 11), and of transport infrastructure and service quality. As the first step, the model is developed for the base year. The traffic flows on different road links are compared with the actual traffic volume counts observed at various locations across the city. The model is then recalibrated to match the actual volume counts. The base year model can then be used to identify and test various short-term measures that can be incorporated to improve the existing transportation system.

Once the transport demand model is calibrated for the base year, it can be used for analyzing the future of the BAU scenario. The inputs for this analysis will be the planned strategies, changes in socio-economic drivers [i.e., population and employment projections (Task 3-2)] and changes in land use (Task 3-3). The BAU scenario assumes that people's travel behaviour (within the same age and socio-economic group) remains the same as the base year.

### Task 3.5 Technology Transitions

An understanding of vehicles, fuels and CO<sub>2</sub> emissions from electricity use in transportation system is essential to learning the implications of travel demand on CO<sub>2</sub> emissions and air quality (Task 3-6).

#### *Vehicles and Fuels*

The transport sector relies primarily on fossil fuels. The dependence on fossil fuels is linked to the domination of internal combustion engine technology on a global scale. In future, however, multiple transitions can affect vehicles and associated infrastructures. There could be:

- i. a change in fuels due to greater use of CNG, bio-fuels, and cleaner petrol and diesel;
- ii. more efficient engines; or
- iii. more electricity for transportation such as metro rail and other rail based transit, as well as electric vehicles (2 wheelers, cars, etc.) for road transport.



The drivers behind these potential changes address urban air quality issues and improve energy security. For example, natural gas has been used as an option for improving air quality in Indian cities, and as a result many cities have built fuelling infrastructures for compressed natural gas (CNG). Bio ethanol blending in petrol is on-going and a 2% blend has already been achieved. By and large, the fuel mix for transport is projected to be quite different between the base year and the future, even in the BAU scenario (Figure 1). The fuel quality has a direct impact on emissions. The fuel mix stands for the share of various fuel types in the city, so the emission factor of a vehicle depends on its fuel mix.

While cities have little role in formulating fuel mix policy, they are heavily impacted by any changes. To understand these transitions, it is important to refer to national studies that document these transitions<sup>19</sup>.

Plans for improvements in the future should take vehicle efficiency into account. The aggregate fuel efficiency is expected to improve in the BAU scenario; in a fuel economy scenario, the improvement is noteworthy, where India will achieve the 4 lit per 100 km global target in 2030 (Figure 2).

**Energy Demand - BAU (Mtoe)**

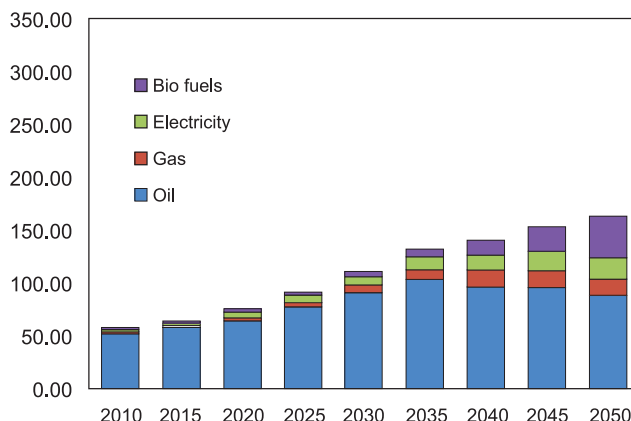

**Figure 1: Fuel Mix for the BAU Scenario<sup>18</sup>**

**Fuel Economy (Cars) (lit gasoline / 100 kms)**

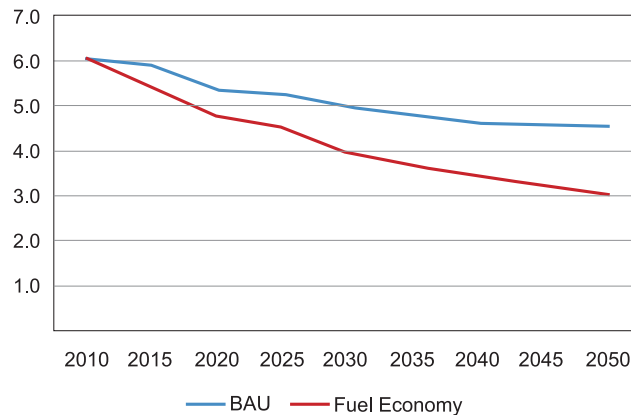

**Figure 2: Fuel Economy Improvement in Cars.**

### Electricity

Electricity is expected to play an increasing role in the future (Figure 1) of transport in cities due to the introduction of metro rail, the electrification of rail tracks and a wider diffusion of electric vehicles (including two wheelers, cars and buses). In many cases, electricity is supplied to cities from outside municipal boundaries, freeing the cities from local pollutants (SO<sub>2</sub>, NO<sub>x</sub>, particulates, etc.). However, cities are obliged to account for CO<sub>2</sub> emissions

<sup>18</sup> Figure 1 is from the Low Carbon City: A Guidebook for City Planners and Practitioners available at [http://www.unep.org/Transport/lowcarbon/Pdf/s/LowCarbonCity\\_Guidebook.pdf](http://www.unep.org/Transport/lowcarbon/Pdf/s/LowCarbonCity_Guidebook.pdf). According to WEO 2012 by 2035 nearly 11% of energy demand from transport would be met by electricity, biofuels and other fuels (IEA, 2012)

<sup>19</sup> CEA CO<sub>2</sub> Database, Available at [http://www.cea.nic.in/reports/planning/cdm\\_co2/user\\_guide\\_ver8.pdf](http://www.cea.nic.in/reports/planning/cdm_co2/user_guide_ver8.pdf)



as per the scope of emission guidelines from the IPCC. The Central Electricity Authority (CEA)<sup>20</sup> shows the grid emission electricity intensity that is compatible with UNFCCC requirements for the base year (latest available 2011). The future grid emission intensity is expected to improve in the BAU (See Figure 3).

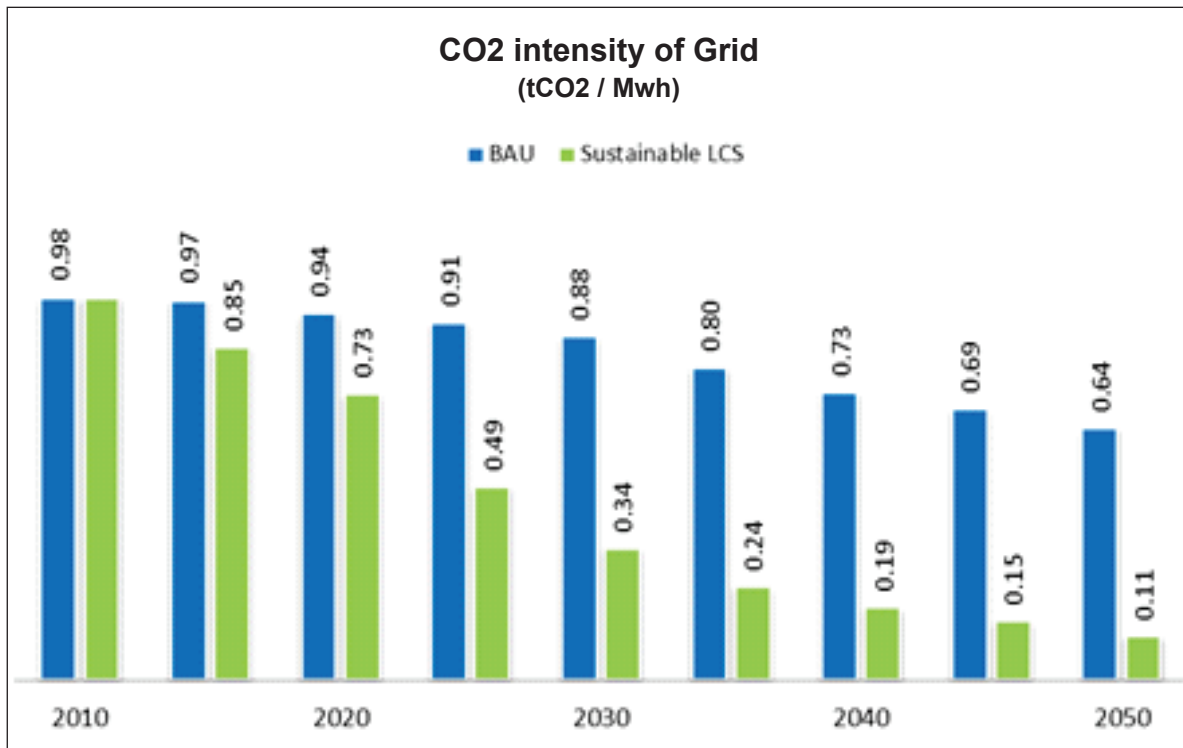

Figure 3: CO<sub>2</sub> Intensity of Electricity from Grid<sup>21</sup>

### Task 3.6 CO<sub>2</sub> Emissions and Air Quality

#### Model Framework

The framework for sustainable urban mobility needs to utilise the four strategic levers:

- Urban form,
- Non-Motorised Transport (NMT),
- Public transport, and
- Technology.

<sup>20</sup> CEA CO<sub>2</sub> Database , Available at [http://www.cea.nic.in/reports/planning/cdm\\_co2/user\\_guide\\_ver8.pdf](http://www.cea.nic.in/reports/planning/cdm_co2/user_guide_ver8.pdf)

<sup>21</sup> Figure 3 is from the Low Carbon City: A Guidebook for City Planners and Practitioners available at [http://www.unep.org/Transport/lowcarbon/Pdf's/LowCarbonCity\\_Guidebook.pdf](http://www.unep.org/Transport/lowcarbon/Pdf's/LowCarbonCity_Guidebook.pdf). According to WEO 2012 by 2035 the grid CO<sub>2</sub> intensity in BAU would be around 0.56 t CO<sub>2</sub>/Mwh (IEA, 2012)



The framework should study the impacts of alternative strategies using key indicators for mobility, safety, and local environment, as well as more aggregate indicators like CO<sub>2</sub> and energy use. It is difficult to find a single model that can estimate all these indicators. One approach is to use a model framework that combines a 4-stage transport model (as described in Task 3-4) with an emission inventory and air diffusion model (e.g. Simple Interactive Model for better Air Quality (**SIM-air**<sup>22</sup>)), which can then analyse the impact of activities from different sectors, including transport, on the local environment, energy use and CO<sub>2</sub> emissions.

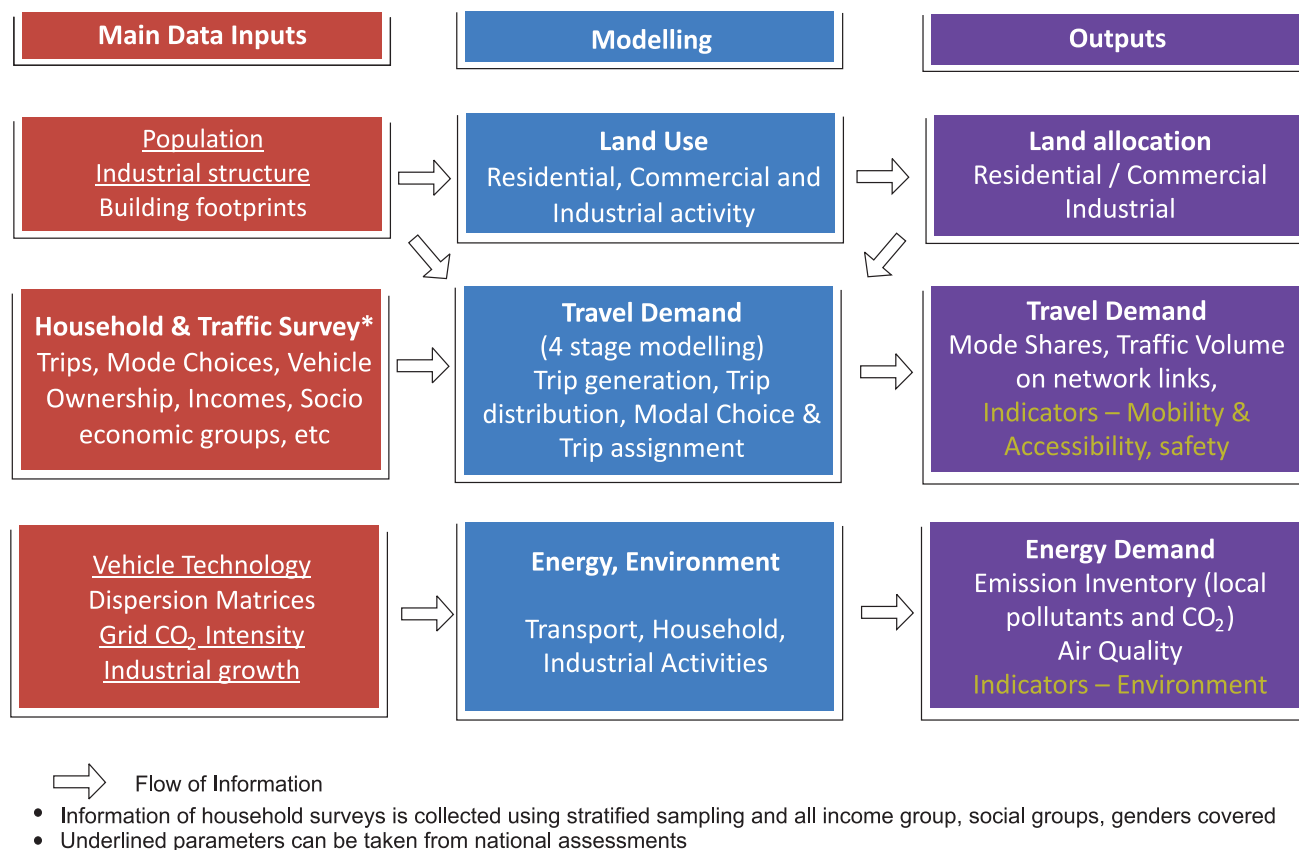

**Figure 4:** Overall Modelling Framework for CMP<sup>23</sup>

### CO<sub>2</sub> Emissions

The outputs from travel activity (available from Task 3-4) in vehicle kilometres can be used to estimate fuel consumption by using the following equation:

<sup>22</sup> For link to the model please use the url- <http://www.urbanemissions.info/model-tools/sim-air.html>

<sup>23</sup> Figure 20, Low Carbon City: A Guidebook for City Planners and Practitioners available at [http://www.unep.org/Transport/lowcarbon/Pdf's/LowCarbonCity\\_Guidebook.pdf](http://www.unep.org/Transport/lowcarbon/Pdf's/LowCarbonCity_Guidebook.pdf)



$$\text{Fuel Consumption} = \text{Vehicle Kilometers Traveled (VKT)}^{24} \times \text{Average Fuel Efficiency}^{25}$$

$$\text{VKT} = \frac{\text{passanger Kilometer (PKM)}}{\text{Average Vehicle Occupancy (refer Table 11)}}$$

**Table 11:** Vehicle Occupancy (Sample)

| Vehicle   | Average Vehicle Occupancy |
|-----------|---------------------------|
| 3 Wheeler | 4.9                       |
| Bus       | 30                        |
| Car       | 2.2                       |
| 2 Wheeler | 1.3                       |

NB: Values are indicative sample. However consultants should include this information in OD survey.

The next step is to estimate the mix of vehicle in terms of their fuel usage. This mix for base year is obtained from the sampling of vehicles during the petrol pump surveys<sup>26</sup>. In case of the future, the fuel mix can be linked to scenario being run (Figure 1 & 7 provides default value as a whole for transport sector but cities can decide them on the basis of their own scenarios). A sample of vehicle mix is given in Table 12 below.

**Table 12:** Vehicles: VKTs and Fuel Mix (Sample)

| Vehicle Type   | VKT (Million) | % Fuel type |        |     |             |
|----------------|---------------|-------------|--------|-----|-------------|
|                |               | Petrol      | Diesel | Gas | Electricity |
| Cars           | 875           | 46          | 47     | 7   | 0           |
| MUV            | 135           | 0           | 100    | 0   | 0           |
| 2Ws            | 3170          | 99          | 0      | 0   | 1           |
| 3Ws            | 482           | 0           | 99     | 0   | 1           |
| Taxis          | 62            | 46          | 47     | 7   | 0           |
| Buses          | 98            | 0           | 100    | 0   | 0           |
| HDVs           | 237           | 0           | 100    | 0   | 0           |
| LDVs           | 77            | 0           | 100    | 0   | 0           |
| Metros / Trams |               | -           | 0      | 0   | 100         |

<sup>24</sup> Source: model developed

<sup>25</sup> Source: petrol pump survey

<sup>26</sup> Petrol pump survey or CNG station survey to be carried out preferably with PUC checking so that vehicle pollution parameters can also be measured. Vehicle sampled should be in proportion to their population.



The fuel use can be converted to CO<sub>2</sub> emissions using default coefficients for different fuels provided in Table 13.

**Table 13:** CO<sub>2</sub> Emission Coefficients for Different Fossil Fuels

| Fuel                          | Giga gram CO <sub>2</sub> /PJ | kg CO <sub>2</sub> /tonne of fuel | Kg CO <sub>2</sub> /lit of fuel |
|-------------------------------|-------------------------------|-----------------------------------|---------------------------------|
| Motor spirit (Petrol)         | 69.30                         | 3101                              | 2.30                            |
| High speed diesel (Diesel)    | 74.1                          | 3214                              | 2.71                            |
| Compressed Natural Gas (CNG)  | 56.1                          | 1691                              | 1.69*                           |
| Liquefied Petroleum Gas (LPG) | 63.1                          | 2912                              | 2.91*                           |

(\* ) For CNG and LPG it is per kg of fuel

The CO<sub>2</sub> emissions from electricity will depend on the CO<sub>2</sub> intensity of grid as given in Figure 3.

### Local Emissions

The emissions of local pollutants can be calculated by multiplying the VKTs with emission coefficients (Refer to Annexure 6 for emission coefficients for the base and coming years). Table 14 provides the annual emissions for PM 2.5 for a vehicle scenario presented in Table 12.

**Table 14:** Emission of PM 2.5

| Vehicle Type   | Emissions PM 2.5 (Tons) |            |          |             | Total      |
|----------------|-------------------------|------------|----------|-------------|------------|
|                | Petrol                  | Diesel     | Gas      | Electricity |            |
| Cars           | 10                      | 50         | 1.2      | -           | 61         |
| MUV            | -                       | 29         | -        | -           | 29         |
| 2Ws            | 269                     | -          | -        | -           | 269        |
| 3Ws            | -                       | 108        | -        | -           | 108        |
| Taxis          | 1                       | 5          | 0        | -           | 6          |
| Buses          | -                       | 50         | -        | -           | 50         |
| HDVs           | -                       | 144        | -        | -           | 144        |
| LDVs           | -                       | 23         | -        | -           | 23         |
| Metros / Trams | -                       | -          | -        | -           | -          |
| <b>Total</b>   | <b>280</b>              | <b>409</b> | <b>1</b> | <b>-</b>    | <b>690</b> |

Emission of other pollutants like NO<sub>x</sub>, PM<sub>10</sub>, VOC, etc can also be calculated in a similar fashion using emission coefficients provided in Annexure 6. The emission of local pollutants is zero for electricity used in vehicles.





### Local Air Quality

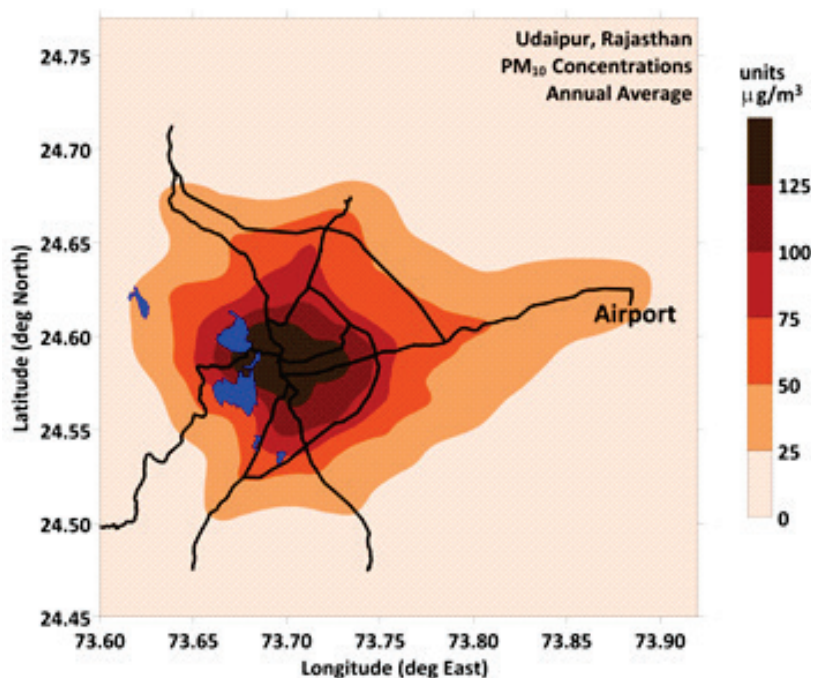

**Figure 5:** Air Pollutant Concentrations Map, PM<sub>10</sub> for Udaipur Using SIM air Model

Pollutant loads are a first level indicator for monitoring air quality. Pollutant loads can be transformed into air pollutant concentrations through SIM Air Model<sup>27</sup>, AIM Enduse/AIM Air Models. These models include a description of technologies at an aggregate level (e.g., two wheeler, car, bus,) and also contain default emission coefficient and vehicle efficiencies.

Local air quality modelling can help create maps of air pollutant concentrations (see Figure 5), Modelling can also help analyse air concentrations related to different strategies (Task 4-1) for achieving sustainable urban mobility.

### Task 3.7 Analysis and Indicators (Comparison with Benchmarks)

The indicators for the BAU scenario are similar to those estimated for the base year (Task 2.8).

<sup>27</sup> More details on air quality models are available from Urban Emissions website <http://www.urbanemissions.info/>



## Task 4: Development of Sustainable Urban Transport Scenarios

### Task 4.1 Framework for Scenario

#### Review of National Carbon Indicators

CO<sub>2</sub> is the predominant constituent of greenhouse gas and therefore indicators for CO<sub>2</sub> at the national level are more easily available than for other greenhouse gases (e.g., CH<sub>4</sub> and N<sub>2</sub>O). **The per capita CO<sub>2</sub> emissions based on the second national communication was 1.0 t CO<sub>2</sub><sup>29</sup> in 2000. Due to the rapid pace of development, the per capita CO<sub>2</sub> emissions increased to 1.33 t CO<sub>2</sub><sup>30</sup> in 2010.** For future emission trajectories, a reference can be made to studies undertaken by the Climate Modelling Forum<sup>31</sup> in 2009, or to more recent modelling work under a UNEP project<sup>32</sup> that provides CO<sub>2</sub> indicators for the BAU as well as sustainable scenarios.

#### Background

The sustainable urban transport scenario visualises social, economic, environmental and technological transitions through which societies respond to climate change, local environment and mobility challenges. The scenario assumes the following:

- Deep emission cuts using low carbon energy sources (such as renewable's, natural gas, nuclear power)
- Use of highly efficient technologies (e.g., improved vehicle efficiency)
- Adoption of behavioural and consumption styles consistent with sustainable development
- Changes in urban development
- Enhanced use of non-motorised and public transport infrastructures.

The sustainable development pathway allows CO<sub>2</sub> mitigation without having to sacrifice the original objective of enhancing economic and social development.

#### Identification and Quantification of Drivers

The main drivers are socio-economic projections, land use, infrastructure and policy change. The socio-economic projections in the BAU scenario can be used, however for changes in land use, infrastructures and policies please refer to Task 4.2.

#### Model Framework

Same as provided in Task 3.1.

<sup>28</sup> Ministry of Environment & Forests (2012) India: Second National Communication to UNFCCC available at <http://moef.nic.in/downloads/public-information/India%20Second%20National%20Communication%20to%20UNFCCC.pdf>.

<sup>29</sup> Considering population as 1021 million and excluding bunker fuel emissions

<sup>30</sup> As per IEA (2012), World Energy Outlook total CO<sub>2</sub> emissions from energy 1635 Million tCO<sub>2</sub> in 2010 and the the population in 2010 as 1224 million

<sup>31</sup> Climate Modelling Forum (2009) India's GHG Emissions Profile <http://moef.nic.in/downloads/home/GHG-report.pdf>

<sup>32</sup> See Figure 13, Low Carbon City: A Guidebook for City Planners and Practitioners available at [http://www.unep.org/Transport/lowcarbon/Pdf's/LowCarbonCity\\_Guidebook.pdf](http://www.unep.org/Transport/lowcarbon/Pdf's/LowCarbonCity_Guidebook.pdf)



## Task 4.2 Strategies for Sustainable Urban Transport Scenario

CMPs must identify investment priorities to help achieve the sustainable city goals. The sustainable scenarios also assume an increase in motorised transport to some extent, which is inevitable given the low level of vehicle use on a per capita basis. Therefore, emphasis is also placed on improving technology in terms of efficiency and emissions. Key strategies can be typically classified into four categories namely:

- Change in urban structure,
- Improving non-motorised transport,
- Improving public transport, and
- Technological changes.

These strategies are essential for developing Smart Cities and will deliver full benefits if they are implemented collectively; however for analysis it may be useful to present them one by one to see the individual effect. The strategies presented here are indicative and the consultants can adapt them to a city's specific circumstances.

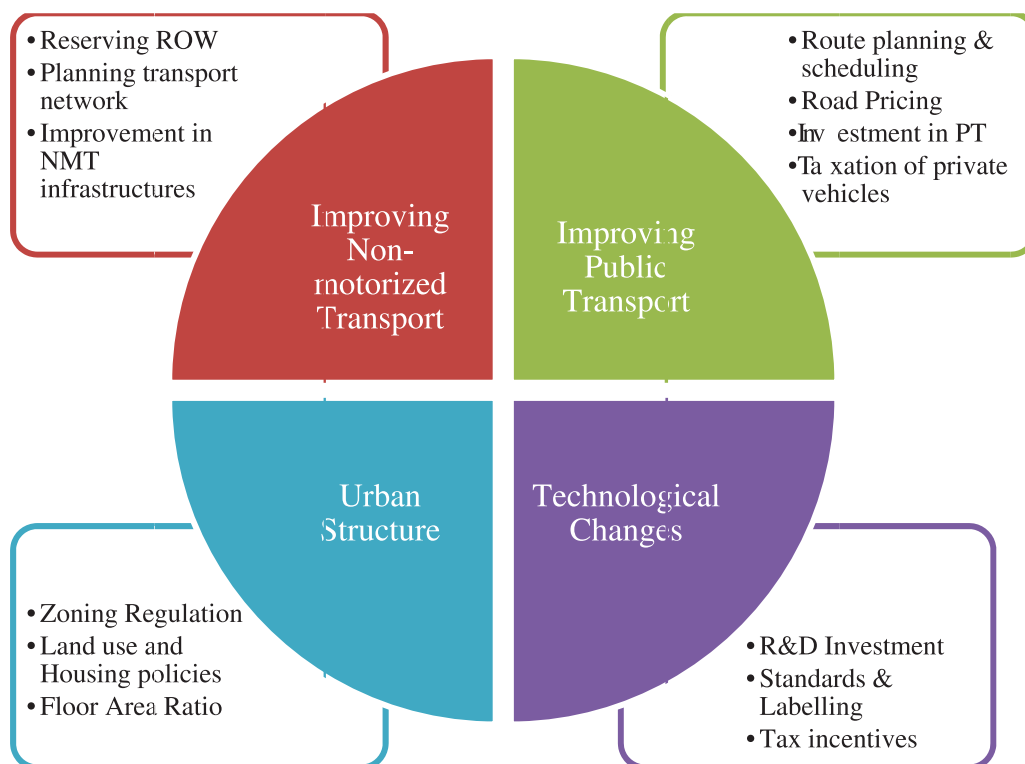

**Figure 6:** Four Broad Strategies and Accompanying Policies Used for Sustainable Scenarios



### **A: Urban Structure**

Urban sprawl and uncontrolled growth of cities result in increased trip lengths, which is not a desirable scenario. Therefore, the focus should be to develop compact cities with high density and multi-nuclei development. It will help shorten trip lengths and improve access to public transport. The changes in zoning regulations and floor area ratio (FAR) include some of the planning and regulatory measures, which can help achieve higher density and compact development.

### **B: Non-Motorised Transport Infrastructure**

The scenario considers improvements in NMT user experience by enhancing footpaths and bicycle lanes. It also addresses improvement in safety and accessibility for pedestrians and bicycles at intersections. Reducing barriers and impediments on roads to improve bicycle safety is another aspect considered under the scenario. Reduced conflicts between NMT users and buses on roads can result in a small increase in bus speed.

### **C: Public Transport**

The public transport scenario includes NMT, as any public transit trip includes a component of NMT for access and egress. Since most Indian cities lack a reliable bus service, two kinds of scenarios for public transport may be considered:

#### **1. Improved bus service with compatible pedestrian and bicycle infrastructure**

The scenario assumes that bus infrastructure and operations are improved so that reliable bus service is available at least along all arterial roads. In addition, initial ideas on operational interventions like better routing and scheduling, improved frequency, better bus stop design, improve bus speed, overall safety and bus user comfort should be incorporated. Option of providing para transit modes on the sub arterial and connecting roads should also be considered. This will help limit the access/egress trip length to less than 1 km. Stress should also be given to the provision of access and egress support infrastructures for walking and bicycle. The above mentioned changes should be used to check the stated preference mode choice of respondents in the household survey. This will help compute the increased demand for public transport in the scenario where limitations of infrastructures (which exists in the BAU scenario) for public and non-motorised transport are removed.

#### **2. Improved bus service and mass rapid transit with compatible pedestrian and bicycle infrastructure**

This scenario includes all improvements detailed above in the improved bus service scenario, as well as a mass rapid transit system on selected traffic corridors. Mass rapid transit options could include BRT (exclusive lanes on all arterial roads), light rail, a metro rail system or mono rail system.<sup>3334</sup>

<sup>33</sup> For an overview of Mass Transit Cost Analysis see Life Cycle Cost Analysis of Five Urban Transport Systems available at <http://www.iutindia.org/downloads/documents>

<sup>34</sup> For an overview of Mass Transit Options see Table 9. Low Carbon City: A Guidebook for City Planners and Practitioners available at [http://www.unep.org/Transport/lowcarbon/Pdf's/LowCarbonCity\\_Guidebook.pdf](http://www.unep.org/Transport/lowcarbon/Pdf's/LowCarbonCity_Guidebook.pdf)



### ***D: Improving Public Transport, NMT and Urban Structure***

This scenario looks at how the implementation of NMT, public transport and urban structure strategies combine and complement each other.

### ***E: Technology***

Technology changes can encompass changes in vehicles design, fuels use, energy use and reduction in CO<sub>2</sub> emissions related to electrically driven vehicle based on central / state policies. See Task 4-4.

### ***F: Regulatory and Financial Measures (Incentives and Disincentives)***

A wide variety of measures can be undertaken to help shift people from private transport modes to sustainable urban transport under a regulatory and financial measure scenario. These measures try to internalise the cost of externalities imposed by private vehicles. Examples of such measures include parking policies, congestion pricing and carbon-taxes by central / state decisions. These are incorporated in the model in form of increased generalized cost of travel by private modes. As an example, described below is the approach for modelling parking policies.

#### **Parking Policies**

Parking is generally low cost if not free in Indian cities. As a result, there is no disincentive for owners of private transport modes like cars and motorised two-wheelers to stop using them to get from one place to another. Instead, there are plenty of incentives to keep using them, as they offer a high amount of personal mobility.

In this scenario, infrastructure improvements are made for pedestrians, bicycles and public transport along with increased parking cost. To implement a robust on-street parking management and enforcement system, on-street parking spaces must be regulated by the cities, and priced according to the demand for parking. The existing parking management system, including current earnings and expenditures, operational systems, and public perception must be documented, assessed and improved. An expanded and improved parking management system can help facilitate the efficient allocation of road space, generate revenue for sustainable transport projects, and encourage a shift to more sustainable modes. **In the four-step model these should increase the generalized cost of travel of motorised modes as compared to NMT and PT mode, which will favour use of NMT and PT modes.**

### **Task 4.3 Transport Demand Analysis of Alternative Strategies for Sustainable Urban Transport**

The above scenario's (A, B, C, D, E and F) aim is to improve transport infrastructure and increase the cost of using personal motorised vehicles. Two methods can be used to estimate travel demand for different modes under alternative scenarios:

#### ***Method 1: Repeating a four-step model***

In this method, a four-step model (as discussed in Task 3-4) is repeated, taking into account changes in parameters associated with different modes such as cost, travel time, availability, comfort and safety. These changes result in a changed impedance to different modes and consequently, changes in people's transport choices. Likely changes to be accounted in the four-step model in alternate scenarios are described in the Table 15.



**Table 15:** Differences in Four-Step Models for Alternative Scenarios

|                    | Change due to   | Urban structure   | NMT infrastructure  | Public transport  | Technology            | Regulatory and financial measures        |
|--------------------|---|---|---|---|-----------------------|--|
| Trip production    | Age-sex distribution and population growth                                | Population distribution in city                                     |   |   |                       |  |
| Trip distribution  | Change in land use parameters and change in impedance for different modes | Distribution of activities (residential, commercial and industrial) |   | Change in impedance (travel time, travel cost, accessibility and reliability) |                       |  |
| Mode choice        | Change in impedance and trip length                                       |   | Change in impedance (Bicycle Compatibility Index and similar for pedestrians) |   | Change in travel cost | Change in travel cost by different modes |
| Traffic assignment | Change in impedance   |   |   |   |                       |  |

**Method 2: Stated preference surveys for mode choice modelling**

The scenarios specifically related to improving infrastructure directly impact people’s choice of mode. In such cases, the effect of different scenarios on the attributes of individual modes should be presented to the respondents. The respondents should then be asked to choose the preferred mode within each scenario. This allows analysts to determine which factors can be compensated for and which factors have a major impact on people’s mode choice. This in turn makes it possible to predict the demand for each mode in different scenarios, even when there is no existing alternative. Also, with the help of this methodology, new alternatives that have not yet been surveyed can be introduced later in the model. This requires incorporating a stated preference choice survey along with the main household survey (survey format 11; part II). The details of the stated preference choice survey are given in Annexure 1 (Household Survey – part II)

**Task 4.4 Technology Transitions under a Low Carbon Scenario**

In the low carbon scenario, the fuel mix is expected to diversify further from BAU towards bio-fuels, electricity and natural gas (Figure 7). Vehicle efficiency will also improve, and thus the overall demand for fuels will be lower. This can be affected by central / state policy intervention.



### Energy Demand - Sustainable LCS (Mtoe)

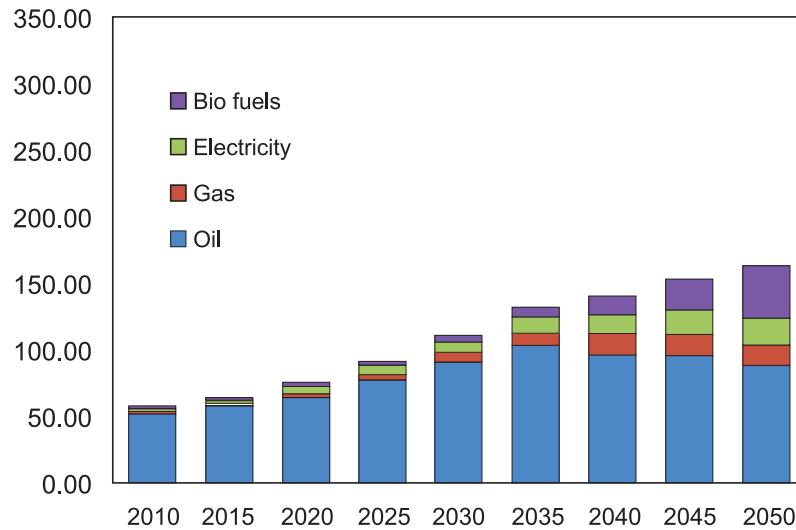

Figure 7: Fuel Mix for Transport in Sustainable Low Carbon Scenario<sup>35</sup>

Another major transformation has to do with electricity, which is quite low in CO<sub>2</sub> intensity and therefore electricity-powered transport modes can become low carbon options.

#### Task 4.5 CO<sub>2</sub> Emissions and Air Quality (Refer to tasks 3.6.)

The model framework is same as the BAU scenario for estimating CO<sub>2</sub> emissions and air quality.

#### Task 4.6 Analysis and Indicators (Comparison with Benchmarks)

The indicators for the sustainable urban transport scenario are similar to those estimated for the base year (Task 2.8); however, some of the indicators are more difficult to measure for the future and can be left out of the list of indicators to be estimated.

<sup>35</sup> Adapted from Figure 11, Low Carbon City: A Guidebook for City Planners and Practitioners available at [http://www.unep.org/Transport/lowcarbon/Pdf's/LowCarbonCity\\_Guidebook.pdf](http://www.unep.org/Transport/lowcarbon/Pdf's/LowCarbonCity_Guidebook.pdf) World Energy Outlook 2012 from IEA shows a diversification towards biofuels and other fuels from oil.



## Task 5: Development of Urban Mobility Plan

Based on the analysis of existing urban transport, BAU scenario, preferred land use and transport scenario vision and strategy for development a detailed urban mobility plan for the city should be prepared.

The mobility plan should provide alternatives to enhance mobility for all users and all modes of travel. It may, if necessary, suggest changes in the existing urban structure and form that encourages an increased use of public transport, walking and NMT. In fact, a mobility plan should be a city’s long-term blueprint for improving accessibility and mobility. The aim of the mobility plan should be to develop an adequate, safe, environmentally friendly, affordable, equitable, comfortable, efficient integrated transport system within the framework of a progressive and competitive market economy. It should create a well-connected network of complete road hierarchy, suggest measures to shift from unsustainable mobility to sustainable modes and integrate freight planning with urban transport. This means that cities need to plan for the people rather than vehicles by providing sustainable mobility and accessibility for all citizens to jobs, education, social services and recreation at an affordable cost and within reasonable time. The desirable modal split for Indian cities i.e. share of public transport modes based on city size are shown in Table 16.

**Table 16:** Desirable Modal Split for Indian Cities (as % of Total Trips)<sup>36</sup>

| City population (in millions) | Mass Transport (%) | Walk Trips (%) | Other Modes (%) |
|-------------------------------|--------------------|----------------|-----------------|
| 0.1 – 0.5                     | 30 - 40            | 40             | 25 – 35         |
| 0.5 – 1.0                     | 40 - 50            |                | 20 – 30         |
| 1.0 – 2.0                     | 50 - 60            |                | 15 – 25         |
| 2.0 – 5.0                     | 60 - 70            |                | 10 – 20         |
| 5.0 +                         | 70 -85             | 25             | 10 – 25         |

In the absence of a suitable modal split method, the above-mentioned modal split levels could be adopted for working out transportation system requirements of urban settlements.

The Urban Mobility Plan should be developed in consultation with stakeholders and on the basis of the analysis carried under Tasks 3 and 4. The plan can be defined along the following lines; however it is important that the plan includes a phasing plan and implementation agencies.

### Task 5.1 Integrated Land Use and Urban Mobility Plan

CMP advocates integrating the urban mobility plan with the land use plan and vice-versa. In most cities, the land use plan is already in force via the DP mechanism, even as the urban mobility plan is being prepared. In such cases, the urban mobility plan must respond to the mobility demands created as a result of the DP. Ideally, the urban

<sup>36</sup> Source: Review of Urban Transportation in India, IIT Kanpur (With reference to Traffic and Transportation Policies and strategies in Urban Areas in India – Final Report, Ministry of Urban Development, Govt of India, New Delhi, 1998)





mobility plan should be an integral part of the DP document. Urban structure determine the travel demand and transport system influence the urban structure. Location of various land use and activity nodes have influence on travel pattern. At the same time, the transport nodes or hubs impact the allocation of land use both at the city and local level. As such, integrating urban development with transport should be the key consideration towards compact and sustainable development of cities. National Urban Transport Policy also emphasised the integrated land use and transport planning. Thus, elements for land use transport integration would be as follows:

- Enabling urban structure
- Completing the hierarchy of roads
- Aligning public transit with high density areas, mixed land use to capture the land value
- Integrating multimodal transit interchange policy and planning integration at vertical and horizontal level

Integrating land use with the urban mobility plan would entail a two-way interaction between the two plans. High density residential areas intertwined with high density employment areas, along with increased travel costs and an efficient public transport system will incite people to use NMT for short trips and public transport for long ones. The land use should be allocated in a manner that encourages short and fewer trips, thereby enabling improved accessibility to activities. This will also help people shift from private travel modes such as cars to NMT (including cycling and walking). Additionally to encourage NMT, neighbourhood design measures such as variety in public spaces, pedestrian footpaths and cycling tracks must be implemented. To summarize, **the land use plan should locate activities in a manner that encourages low-carbon mobility** and the urban mobility plan, in turn, should facilitate access to activities.

## Task 5.2 Formulation of the Public Transport Improvement Plan

CMP divides Public Transport Improvement Plans into a number of sections, including service improvements for buses, trams and para-transit, appropriate MRT options and infrastructure development plans and intermodal integration plans.

Formulating a public transport improvement plan in a small-sized Indian city can involve several challenges. These can range from assessing transport demand to service provision and its alignment with land use. **Most Indian cities, especially middle-sized ones, do not have an extensive public transport network. Therefore, it is very difficult to judge the demand for public transport based on revealed preferences. The only alternative is the data collected on stated preferences, which should be used for demand assessment of public transport systems.**

Improving the public transport involves infrastructural improvements like reserving lanes and tracks and operational improvements like optimizing routes and scheduling. It is necessary to identify the type of improvement required to improve the level of service. The improvement in level of service is likely to not only maintain the existing modal share of public transport but also create a shift from other modes to public transport. These shifts are determined by the city's structure and travel behaviour. The fleet must be optimized based on the demand: instead of offering a 50-seat bus every 20 minutes, it might be better to provide 25-seat buses every 10 minutes. Secondly, most of these small cities are likely to grow into large metropolitan centres in future, so a gradual progression towards public transport technology can also be suggested. For example, a strategy could start with



city buses and progress to BRT and eventually to a metro rail. This is also important from the low-carbon point of view, as operating a public transport system at low capacities will result in high per-capita carbon emissions from transport use, in comparison to a PT system operating near its capacity.

System planning should consider not only where terminal, routes and stops are placed (i.e. routes and stops), but also whether they are accessible to all potential users. The plans for the system should take into account the accessibility issues for pedestrians and cyclists, the differentlyabled and elderly people, as well as private vehicle users after they have parked their vehicles.

### **Task 5.3 Preparation of Road Network Development Plan**

CMP should list out road projects which are to be developed, strengthened, upgraded and interconnected including hierarchical road network, arterial road construction / widening projects, secondary road construction / widening projects, intersection improvement projects, flyover projects, railway over bridge or underpass projects. The hierarchical road network should be based on travel demand. CMPs should reflect induced demand effects to estimate the overall benefit of any new road capacity. In addition to assigning the proper hierarchy to the road network, which is derived from its land use, it is important to consider urban roads as streets and function to be assigned. The availability of additional road capacity often induces new travel. Thus, the induced demand must be considered for project cost and benefit. Considering that the very high number of trips recorded in India are NMT, it is essential that roads prioritise space for NMT. Despite the latent demand for motorised vehicle use, proposals to improve motorised vehicle mobility by increasing road space under the pretext of easing congestion should be discouraged as much as possible. New construction/ widening projects, flyover projects and underpass projects must also be discouraged.

### **Task 5.4 Preparation of NMT Facility Improvement Plan**

In preparing NMT facility improvement plans, the most important consideration to keep in mind is that a large proportion of urban travel involves using these transport modes. Thus, it is essential to identify specific streets and the street types preferred by individuals when walking or using a bicycle. As stated earlier, if the TAZ sizes are small, the generalized cost of spatial interaction between zones can be obtained from the road network using street attributes and their suitability for walking and bicycle use. The modelling spatial interaction should represent the current preferences and demand, as well as for stated choices, which represent demand for walking and bicycling if a certain level of infrastructure is provided. When planning NMT infrastructure, due consideration should be given to the existing networks and not patches. For example, all roads where individual are likely to walk should include at least 2 metres of clear, walkable footpath. Moreover, all potential walking or bicycling locations should have NMT infrastructure, including comfortable footpaths, cycle tracks, streetlights, cycle stand, formal pedestrian crossing and NMT-designed signals at all junctions. Access to activities and transport services should also be taken into account. The design of these facilities should be such that they are inclusive, and provide travel opportunities to the so-called disadvantaged sectors of society (the physically challenged, urban poor, women, children and individuals with special needs).



While at a policy level, NMT planning may be accepted, detailed NMT improvement plans and traffic management measures should be worked out for CBD, commercial centres, and other major activity centres. These detailed plans define NMT policy for the whole region, and provide the cost basis for implementing such policy. Besides, on-the-ground traffic management for pedestrians and cyclists, city level infrastructure planning for pedestrians and cyclists, who account for 40 to 50% of trips in mid-sized should also be done.

### Task 5.5 Freight Movement Plan

Freight traffic and movement of goods within city and passing through inter-city traffic affects the overall city mobility. Since the transportation of goods will grow with economic growth, the planning for the movement of goods needs to be given a much greater focus. The planning for freight movement should address the problem of intermixing of local and regional traffic. The plan should assess the expected growth of freight by taking into consideration the past trends, extent of industrial and commercial activities distribution and storage facilities in the city, location of wholesale markets, direction of city growth etc. and indicate the need for relocation of wholesale markets and shifting of truck terminals at appropriate locations, preferably on the periphery of city.

The freight planning needs to be integrated with mobility plan by organising the freight movement in the city. Apart from the motorised modes of freight transport, non-motorised modes also play significant role in the total freight movement. It is, therefore, important to recognise the benefit of non-motorised freight transport while addressing the issue of the last leg connectivity in freight movement. Location of distribution centres for goods should be based on the scale of movement of goods. The freight management plan should address issues regarding the location of distribution centres, mode of transport, time restrictions, air and noise pollution etc. For example, a regional distribution centre can be located on the periphery of the city in conjunction with transport network infrastructure and a local distribution centres can be located suitable at a number of locations within the city preferably closer to commercial centres.

### Task 5.6 Mobility Management Measures

In CMP, traffic management plans cover parking management plans, traffic control measures, intermodal facilities, demand management measures, traffic safety plan and ITS.

Mobility management measures suggested in the CMP should enable enhanced use of public transit and NMT modes. As shown in Table 17, additional measures should be added to increase the cost to discourage the use of personal motorised travel, including the taxation of cars and fuel, land use planning that encourages shorter travel distances and traffic management by reallocating space on the roads.



**Table 17:** TDM Measures Varying from Push and Pull Factors

| TDM Measures                            |  |
|---|--|
| Taxation of cars and fuel               | Tele-working   |
| Closure of city centres for car traffic | Land-use planning encouraging shorter travel distances           |
| Road pricing                            | Traffic management reallocating space between modes and vehicles |
| Parking control                         | Parking fee, No-parking zones                                    |
| Decreasing speed limits                 | Improved infrastructure for walking and biking                   |
| Avoiding major new road infrastructure  | Optimum use of existing road infrastructure                      |

Source: Gärling et al. (2002)

### Task 5.7 Development of Fiscal Measures

Fiscal measures should also be considered to achieve a balanced modal split, and to secure the budget necessary to implement urban transport projects. As fiscal measures usually correspond to institutional and regulatory measures, the following aspects may have to be examined in the CMP document for consideration of state government:

- Fare policy for public transportation, intermediate public transport and parking;
- Subsidy policy for public transport operators and intermediate transport operators;
- Taxation on private vehicles and public transport vehicles;
- Permits and regularisation of intermediate public transport;
- Potential for road congestion charging;
- Influence private vehicle usage through parking and disincentivise free parking with private developments;
- Setting up of Unified Metropolitan Transport Authority to coordinate urban transport and related issues in million plus cities;
- Creating Special Purpose Vehicles particularly for Mass Transit System.

### Task 5.8 Mobility Improvement Measures and NUTP Objectives

The land use and transport measures proposed in the CMP will improve the mobility in the metropolitan area and cover the critical issues addressed in the NUTP. A table can be prepared summarising the relationship between the NUTP objectives and the measures proposed in the study, together with a classification of the measures according to their implementation timeframe (immediate, short, medium and long term) as per the provision of NUTP.

Traffic Engineering Measures already covered like improvement of Road / Junction sections need to be identified. City-specific plans like Tourist management plan, water transport plan, hill transport like rope ways etc may be prepared as part of CMP.



## Task 6: Preparation of the Implementation Program

### Task 6.1 Preparation of Implementation Programs

Task 5 involves the development of various urban mobility measures as discussed earlier. The necessary interventions for these measures include a set of actionable projects to be implemented in the city and prioritised based on a linear timeframe. CMPs should guide cities to prioritise various projects simultaneously such that preliminary study and feasibility assessment of long-term projects can be an immediate priority. CMPs can base their timeframe into the following categories:

- Immediate priority / actions (0 - 2 years)
- Short term (2-5 years)
- Medium term (5-10 years)
- Long term (more than 10 years)

All the projects are presented to the city stakeholders and the implementing agency to identify the priority of the projects.

It should be made clear in the CMP that the project list is merely a description of priority projects. **Detailed project reports with cost estimates and financing will have to be prepared by the city authorities separately** and approved by the urban local body and state government before seeking funding from the MoUD or any other agency.

### Task 6.2 Identification and Prioritization of Projects

All sustainable transport projects must have equal priority, but their planning can be phased based on short, medium and long-term planning. The prioritisation of projects into short, medium and long term can be done using the following criteria:

- **Immediate and short-term measures** are aimed at improving the safety and accessibility of pedestrians, cyclists and public transport users, area level traffic circulation plans and measures like implementing traffic signals.
- **Medium-term measures** typically involve corridor-level projects such as implementing cycle tracks and mass-transit corridors, city level initiatives like public transport fleet improvement and efficient scheduling, developing area level cycle networks and Public Bicycle Sharing (PBS) schemes, parking policy development and implementation in the city. They are primarily aimed at halting the decrease in the city's public transport and non-motorised transport mode shares.
- **Long-term measures** include implementing the overall vision of the CMP. This includes developing city-level networks for walking and cycling, bus systems, mass-transit networks, parking regulation measures and pricing strategies as a demand management tool, improving the overall road network to provide adequate accessibility for existing developed areas and new ones as the city grows, centralised control measures for traffic signal systems and public transport operations



An additional set of criteria for prioritising projects can be as follows:

- Balance between improving existing infrastructure and creating new infrastructure in upcoming areas of development (Preference can be given to projects that improve existing infrastructure by giving them higher scores)
- Benefits measured in terms of mobility and accessibility, safety, energy, environment and CO<sub>2</sub> mitigation.

These project ideas are presented to the stakeholders in order to get their feedback on both the projects and their prioritisation. Multi Criteria Assessment (MCA) technique<sup>37</sup> can be used to evaluate alternate options using stakeholder feedback. The final list of identified projects then undergoes detailed studies on implementation, cost estimates and likely funding agencies.

### Task 6.3 Funding of Projects

Overtime and following constitutional amendments (73rd and 74th), the strategic importance of Urban Local Bodies (ULBs) in developing urban amenities and delivering services which directly influence the well-being of city's local populace have significantly increased. However a commensurate increase in the ULB's resource base is yet to happen. This imbalance has resulted in the growing dependence of ULBs on the state government and subsequently on the central government for financing urban infrastructure projects. The present structure of fiscal dependence of ULBs is outlined in Figure 8<sup>38</sup>.

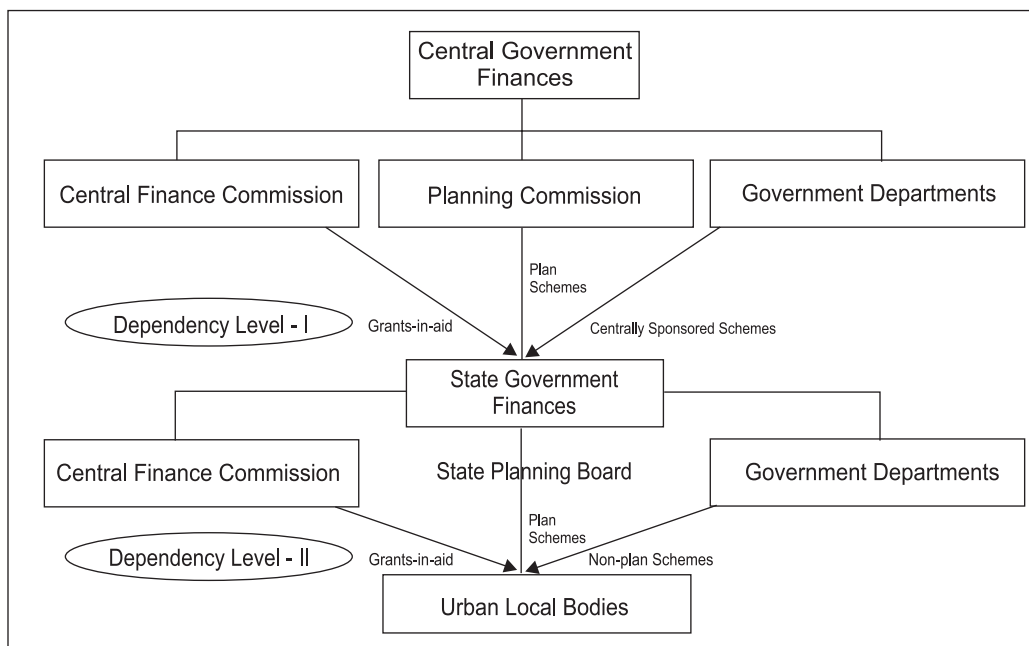

**Figure 8:** Fiscal Dependence of ULBs

<sup>37</sup> Refer MCA handbook for methodology for prioritisation [http://eprints.lse.ac.uk/12761/1/Multi-criteria\\_Analysis.pdf](http://eprints.lse.ac.uk/12761/1/Multi-criteria_Analysis.pdf)

<sup>38</sup> Source: RBI working paper



As the CMP is a long-term vision for the city authority, the overall ownership of the CMP lies with ULBs. Given the ULB's dependence on funding, a city's CMP should make a resource assessment for all the projects listed in the CMP and should suggest the city authority, city-specific and project-specific indicative source of financing for the project. Financing options for urban transport needs to be suggested based on the details given in the toolkit on financing and financial analysis of urban transport available at [iutindia.org/CapacityBuilding/Toolkits.aspx](http://iutindia.org/CapacityBuilding/Toolkits.aspx).

## Task 6.4 Monitoring of CMP Implementation

As per the MoUD advisory, CMP is the basis for approving projects, plans and various regulatory measures within the city related to transport, and it is therefore important to monitor and measure the impact of interventions taken as an outcome of CMP.

The first level of monitoring can be with regard to the status of implementation of the Urban Mobility Plan (Task 5) in terms of time frames proposed and achieved. This is helpful to understand the pace of CMP implementation.

The second level of monitoring can be to understand the impact of CMP implementation. The indicators created as a part of CMP can form the basis of this monitoring which can be done on a biannual basis. CO<sub>2</sub> emissions are also a part of these indicators, and if a city wants to register its CMP as a nationally appropriate mitigation action<sup>39</sup> (NAMA), then a more comprehensive approach for monitoring reporting and verification (MRV<sup>40</sup>) is required.

---

<sup>39</sup> Cities have registered their Comprehensive Mobility Plans as NAMA (Shukla, P.R., Sharma, S, & Dhar, S 2013 NAMA in transport sector [http://www.unep.org/Transport/lowcarbon/Pdf/s/NAMA\\_ClimateFinancing.pdf](http://www.unep.org/Transport/lowcarbon/Pdf/s/NAMA_ClimateFinancing.pdf) or visit UNFCCC website for a listing of NAMAs <http://www4.unfccc.int/sites/nama/SitePages/Home.aspx> )

<sup>40</sup> For a detailed guidance on MRV for NAMAs is available in the following guidebook [http://www.lowemissiondevelopment.org/docs/resources/Guidance\\_for\\_NAMA\\_Design\\_2013\\_.pdf](http://www.lowemissiondevelopment.org/docs/resources/Guidance_for_NAMA_Design_2013_.pdf)





## Section III:

# Methodology for Small Cities

---

There are 73 cities as per 2011 census that have a **population of more than 0.5 million**. Most of these cities require large investments in urban transport infrastructures (e.g., BRT, metros) to prevent unchecked growth of private motorised transport and transform them into smart cities. Some of the decisions on transport projects they take now would however have long-term consequences and therefore all these cities need to go for a full CMP, which looks at accessibility for all socio economic groups and genders, studies impact of transport system on safety, environment and CO<sub>2</sub> emissions. The revised toolkit has provided a comprehensive approach for these cities.

According to 2011 Census, 60% of urban population lives in towns and **cities with population less than 0.5 million**. Most of these cities have small size, short trip lengths, and high share of walking and will benefit through improvement in operational effectiveness of para-transit and public transport systems. In the next 5-10 years, no major infrastructure changes in these cities are envisaged. In such a situation, undertaking a full CMP is not required since it involves a reasonable time (minimum one year) and reasonable budget to enable data collection, analysis and report write up. Such cities could still make use of CMP toolkit with the following modifications which reduce the need for extensive modelling.



**Table 1:** Tasks to be followed for Small Cities

| Task   | Modifications for Limited CMP   |
|--------|---|
| Task 2 | <p><b>Data Collection:</b></p> <p>Table 5 provides an overview of the data needs for studying the existing transport system and these can be reduced depending on data availability within the cities. Some reduction in the data might be automatic, for example presence of cycle tracks, signalised crossing and data on public transport may not be collected if these are not present in the city.</p>   |
| Task 3 | <p><b>Development of BAU Scenario</b></p> <p>Refer to Task 3-4 Transport Demand Analysis</p> <p>The Model Framework (Figure 6) recommends 4 Stage modelling for transport demand. 4 stage modelling however involves setting up of computer based models and extensive data analysis, therefore for smaller cities it is optional and they can instead go for the following approach.</p> <p>They can estimate indicators for existing system (Table 10) based on data collection.</p> <p>For future years based on stakeholder consultations target modes shares for horizon years can be decided exogenously</p> <p>The present trip rates and trip lengths for different modes for the present year can be computed from a household survey.</p> <p>A quick estimate of the future travel demand can then be done by using the cross classification method (See Example Annex 12). Future projection of socio demographic as well as built form variables can be used to predict the travel behaviour in the stated future year as shown in Annexure 12.</p> <p><b>Local Air Quality</b></p> <p>Refer to Task 3-6: CO<sub>2</sub> Emissions and Air Quality</p> <p>Local air quality modelling requires dispersion modelling and this is optional for smaller cities since they might not have air quality monitoring equipment necessary for model calibration and also have low level of motorisation.</p> |
| Task 4 | <p><b>Sustainable Urban Transport Scenarios</b></p> <p>Once again, since 4 step modelling is optional, the cities can based on a stakeholder consultation process decide the target modal shares for this scenario and then estimate the travel demand from the nature of interventions proposed with regard to built environment.</p>  |

## Section IV:

# Annexure

---

## Annexure 1. Sample Survey Forms

### Survey Format 1: Road Inventory

- a. Road Inventory for Motorised Vehicles
- b. Footpath Inventory
- c. NMV Lane Inventory
- d. Infrastructural Facilities along road
- e. Encroachment & Vehicle Restriction

### Survey Format 2: Junction Inventory

### Survey Format 3: Traffic Volume Count

### Survey Format 4: Parking Survey

- a. On-Street Parking
- b. Off-Street Parking

### Survey Format 5: Speed & Delay Survey

- a. For Car
- b. For Public Transport (City Bus)

### Survey Format 6: Inventory for Cycle Rickshaws and Autos

- a. Fleet Inventory for Auto Rickshaws
- b. Route Inventory for Shared Autos
- c. Cost & Fare of Shared Autos

### Survey Format 7: Inventory for Public Transport

- a. Inventory for BRT
- b. Inventory for City Bus
- c. Bus Terminal
- d. Fleet Inventory
- e. Cost & Fare



- f. Route Inventory
- g. Boarding & Alighting
- h. Interchange Survey

Survey Format 8: Landuse Survey along PT Corridor (BRT / Metro)

Survey Format 9: Freight Survey

Survey Format 10: Traffic Safety

Survey Format 11: Household Survey

- Part – I: Revealed Preference Survey
- Part – II: Stated Preference Survey

Survey Format 12: Energy Consumption in Transport: City level

Survey Format 13: Vehicle Inventory –Registered Vehicles at City

Survey Format 14: Vehicle Survey at Petrol Pump

Survey Format 15: Air Quality levels – Secondary Data



**Survey Format 1. Road Inventory**

| Road Inventory for Motorised Vehicles (Survey Format 1a) |             |    |              |              |                     |                             |                  |               |                        |     |                       |                        |
|--|-------------|----|--------------|--------------|---------------------|-----------------------------|------------------|---------------|------------------------|-----|-----------------------|------------------------|
| Road Name  | Node Number |    | Length (kms) | No. of lanes | Divided / Undivided | Carriage Way (Kerb to Kerb) |                  |               | Service Lane Width (m) |     | Street Lighting (Y/N) | Right of way width (m) |
|  | From        | To |              |              |                     | LHS width (m)               | Median width (m) | RHS width (m) | LHS                    | RHS |                       |                        |
|  |             |    |              |              |                     |                             |                  |               |                        |     |                       |                        |
|  |             |    |              |              |                     |                             |                  |               |                        |     |                       |                        |
|  |             |    |              |              |                     |                             |                  |               |                        |     |                       |                        |
|  |             |    |              |              |                     |                             |                  |               |                        |     |                       |                        |
|  |             |    |              |              |                     |                             |                  |               |                        |     |                       |                        |
|  |             |    |              |              |                     |                             |                  |               |                        |     |                       |                        |
|  |             |    |              |              |                     |                             |                  |               |                        |     |                       |                        |
|  |             |    |              |              |                     |                             |                  |               |                        |     |                       |                        |
|  |             |    |              |              |                     |                             |                  |               |                        |     |                       |                        |
|  |             |    |              |              |                     |                             |                  |               |                        |     |                       |                        |
|  |             |    |              |              |                     |                             |                  |               |                        |     |                       |                        |
|  |             |    |              |              |                     |                             |                  |               |                        |     |                       |                        |
|  |             |    |              |              |                     |                             |                  |               |                        |     |                       |                        |
|  |             |    |              |              |                     |                             |                  |               |                        |     |                       |                        |
|  |             |    |              |              |                     |                             |                  |               |                        |     |                       |                        |
|  |             |    |              |              |                     |                             |                  |               |                        |     |                       |                        |
|  |             |    |              |              |                     |                             |                  |               |                        |     |                       |                        |
|  |             |    |              |              |                     |                             |                  |               |                        |     |                       |                        |
|  |             |    |              |              |                     |                             |                  |               |                        |     |                       |                        |
|  |             |    |              |              |                     |                             |                  |               |                        |     |                       |                        |
|  |             |    |              |              |                     |                             |                  |               |                        |     |                       |                        |



| Footpath Inventory (Survey Format 1b) |            |           |               |                |                       |               |            |           |               |                |                     |  |  |
|---------------------------------------|------------|-----------|---------------|----------------|-----------------------|---------------|------------|-----------|---------------|----------------|---------------------|--|--|
| LHS                                   |            |           |               |                |                       |               | RHS        |           |               |                |                     |  |  |
| Type (P / UP)                         | Length (m) | Width (m) | Encroachment* | Lighting (Y/N) | Barrier free design** | Type (P / UP) | Length (m) | Width (m) | Encroachment* | Lighting (Y/N) | Barrier free design |  |  |
|                                       |            |           |               |                |                       |               |            |           |               |                |                     |  |  |
|                                       |            |           |               |                |                       |               |            |           |               |                |                     |  |  |
|                                       |            |           |               |                |                       |               |            |           |               |                |                     |  |  |
|                                       |            |           |               |                |                       |               |            |           |               |                |                     |  |  |
|                                       |            |           |               |                |                       |               |            |           |               |                |                     |  |  |
|                                       |            |           |               |                |                       |               |            |           |               |                |                     |  |  |
|                                       |            |           |               |                |                       |               |            |           |               |                |                     |  |  |
|                                       |            |           |               |                |                       |               |            |           |               |                |                     |  |  |
|                                       |            |           |               |                |                       |               |            |           |               |                |                     |  |  |
|                                       |            |           |               |                |                       |               |            |           |               |                |                     |  |  |
|                                       |            |           |               |                |                       |               |            |           |               |                |                     |  |  |
|                                       |            |           |               |                |                       |               |            |           |               |                |                     |  |  |
|                                       |            |           |               |                |                       |               |            |           |               |                |                     |  |  |
|                                       |            |           |               |                |                       |               |            |           |               |                |                     |  |  |
|                                       |            |           |               |                |                       |               |            |           |               |                |                     |  |  |
|                                       |            |           |               |                |                       |               |            |           |               |                |                     |  |  |
|                                       |            |           |               |                |                       |               |            |           |               |                |                     |  |  |
|                                       |            |           |               |                |                       |               |            |           |               |                |                     |  |  |

**Note:** P: Paved; UP: Unpaved      \*parking/Vendors/Trees/Electric Poles/Other obstacles      \*\*access at entry/guiding tiles/audible/none



| NMMV lane Inventory (Survey Format 1C) |           |                      |  |                  |                |            |           |                      |  |
|--|-----------|----------------------|--|------------------|----------------|------------|-----------|----------------------|--|
| LHS                                    |           |                      |  |                  | RHS            |            |           |                      |  |
| Length (m)                             | Width (m) | Pavement condition * | Segregation tools to separate NMMV lane from other mode ** | Encroachment *** | Lighting (Y/N) | Length (m) | Width (m) | Pavement condition * | Segregation tools to separate NMMV lane from other mode ** |
|  |           |                      |  |                  |                |            |           |                      |  |
|  |           |                      |  |                  |                |            |           |                      |  |
|  |           |                      |  |                  |                |            |           |                      |  |
|  |           |                      |  |                  |                |            |           |                      |  |
|  |           |                      |  |                  |                |            |           |                      |  |
|  |           |                      |  |                  |                |            |           |                      |  |
|  |           |                      |  |                  |                |            |           |                      |  |
|  |           |                      |  |                  |                |            |           |                      |  |
|  |           |                      |  |                  |                |            |           |                      |  |
|  |           |                      |  |                  |                |            |           |                      |  |
|  |           |                      |  |                  |                |            |           |                      |  |
|  |           |                      |  |                  |                |            |           |                      |  |
|  |           |                      |  |                  |                |            |           |                      |  |
|  |           |                      |  |                  |                |            |           |                      |  |
|  |           |                      |  |                  |                |            |           |                      |  |
|  |           |                      |  |                  |                |            |           |                      |  |
|  |           |                      |  |                  |                |            |           |                      |  |
|  |           |                      |  |                  |                |            |           |                      |  |
|  |           |                      |  |                  |                |            |           |                      |  |
|  |           |                      |  |                  |                |            |           |                      |  |
|  |           |                      |  |                  |                |            |           |                      |  |
|  |           |                      |  |                  |                |            |           |                      |  |
|  |           |                      |  |                  |                |            |           |                      |  |

Note: \* Good/Poor/Bad      \*\* painted marking/kerbed/none      \*\*\* Parking/Vendors







## Survey Format 2. Junction Inventory

| Intersection Name | Type of intersection* | Type of traffic operation** | Traffic calming tools | Barrier free access | Other NMV facilities (NMV box etc) | Intersection Design (No. of arms) |
|-------------------|-----------------------|-----------------------------|-----------------------|---------------------|------------------------------------|-----------------------------------|
|                   |                       |                             |                       |                     |                                    |                                   |
|                   |                       |                             |                       |                     |                                    |                                   |
|                   |                       |                             |                       |                     |                                    |                                   |
|                   |                       |                             |                       |                     |                                    |                                   |
|                   |                       |                             |                       |                     |                                    |                                   |
|                   |                       |                             |                       |                     |                                    |                                   |
|                   |                       |                             |                       |                     |                                    |                                   |
|                   |                       |                             |                       |                     |                                    |                                   |
|                   |                       |                             |                       |                     |                                    |                                   |
|                   |                       |                             |                       |                     |                                    |                                   |
|                   |                       |                             |                       |                     |                                    |                                   |
|                   |                       |                             |                       |                     |                                    |                                   |
|                   |                       |                             |                       |                     |                                    |                                   |
|                   |                       |                             |                       |                     |                                    |                                   |
|                   |                       |                             |                       |                     |                                    |                                   |
|                   |                       |                             |                       |                     |                                    |                                   |
|                   |                       |                             |                       |                     |                                    |                                   |
|                   |                       |                             |                       |                     |                                    |                                   |
|                   |                       |                             |                       |                     |                                    |                                   |

\* 1 – Un-Signalised      2 – Signalised      3 – Roundabout      4 – Signalised Roundabout      5 – Others  
 \*\* M – Manual      A – Automated



**Survey Format 3. Traffic volume count at screen line, cordon and intersection**

| Location | Direction from   |           | Date/Month Year |          | Goods Vehicle |     |                   |               |          |      |     |      |               |      |            |             |       |                |            |       |       |                |     |        |                                |        |  |
|----------|------------------|-----------|-----------------|----------|---------------|-----|-------------------|---------------|----------|------|-----|------|---------------|------|------------|-------------|-------|----------------|------------|-------|-------|----------------|-----|--------|--------------------------------|--------|--|
|          | Count station no | Direction | Right           | Straight | Left turn     | Day | Passenger vehicle |               |          |      |     |      | Goods Vehicle |      |            |             |       |                |            |       |       |                |     |        |                                |        |  |
|          |                  |           |                 |          |               |     | Light fast        |               |          | Slow |     |      | Heavy fast    |      | Light fast |             | Slow  |                |            |       |       |                |     |        |                                |        |  |
|          |                  |           |                 |          |               |     | City bus          | Intercity bus | Mini bus | Car  | MTW | Auto | Van           | Jeep | Taxi       | Shared Auto | Cycle | Cycle rickshaw | pedestrian | Other | Truck | MAV / Trailers | LCV | Others | Cycle rickshaw trolley / carts | Others |  |
| 6 – 7 am |                  |           |                 |          |               |     |                   |               |          |      |     |      |               |      |            |             |       |                |            |       |       |                |     |        |                                |        |  |
| .....    |                  |           |                 |          |               |     |                   |               |          |      |     |      |               |      |            |             |       |                |            |       |       |                |     |        |                                |        |  |
| 5 – 6 pm |                  |           |                 |          |               |     |                   |               |          |      |     |      |               |      |            |             |       |                |            |       |       |                |     |        |                                |        |  |
| .....    |                  |           |                 |          |               |     |                   |               |          |      |     |      |               |      |            |             |       |                |            |       |       |                |     |        |                                |        |  |







## Survey Format 5. Speed and Delay Survey

Speed & Delay – Car (Survey Format 5a)

| Sl. No. | Road name | From Node | To Node | Distance (km) | Start Time (min) | End Time (min) | Time | Delay (sec) | Purpose of delay |
|---------|-----------|-----------|---------|---------------|------------------|----------------|------|-------------|------------------|
|         |           |           |         |               |                  |                |      |             |                  |
|         |           |           |         |               |                  |                |      |             |                  |
|         |           |           |         |               |                  |                |      |             |                  |
|         |           |           |         |               |                  |                |      |             |                  |
|         |           |           |         |               |                  |                |      |             |                  |
|         |           |           |         |               |                  |                |      |             |                  |
|         |           |           |         |               |                  |                |      |             |                  |
|         |           |           |         |               |                  |                |      |             |                  |
|         |           |           |         |               |                  |                |      |             |                  |

Speed & Delay – PT (Survey Format 5b)

| Sl. No. | Route name | Road Name | From Node | To Node | Distance (km) | Start Time (min) | End Time (min) | Time | Delay (sec) | Purpose of delay |
|---------|------------|-----------|-----------|---------|---------------|------------------|----------------|------|-------------|------------------|
|         |            |           |           |         |               |                  |                |      |             |                  |
|         |            |           |           |         |               |                  |                |      |             |                  |
|         |            |           |           |         |               |                  |                |      |             |                  |
|         |            |           |           |         |               |                  |                |      |             |                  |
|         |            |           |           |         |               |                  |                |      |             |                  |
|         |            |           |           |         |               |                  |                |      |             |                  |
|         |            |           |           |         |               |                  |                |      |             |                  |
|         |            |           |           |         |               |                  |                |      |             |                  |
|         |            |           |           |         |               |                  |                |      |             |                  |
|         |            |           |           |         |               |                  |                |      |             |                  |



### Survey Format 6. Inventory for Cycle Rickshaws and Autos

| Fleet inventory – auto rickshaw (Survey Format 6a) – Secondary Data |                             |                        |                                |                        |                               |           |         |                                |
|---|-----------------------------|------------------------|--------------------------------|------------------------|-------------------------------|-----------|---------|--------------------------------|
| Owner (owned/<br>rented)  | Type of fleet<br>(capacity) | Use (shared or<br>not) | Average<br>vehicular<br>km/day | Average<br>vehicle age | Average<br>earning per<br>day | Occupancy |         | Average passen-<br>ger per day |
|   |                             |                        |                                |                        |                               | Peak hour | Average |                                |
|   |                             |                        |                                |                        |                               |           |         |                                |
|   |                             |                        |                                |                        |                               |           |         |                                |
|   |                             |                        |                                |                        |                               |           |         |                                |
|   |                             |                        |                                |                        |                               |           |         |                                |
|   |                             |                        |                                |                        |                               |           |         |                                |
|   |                             |                        |                                |                        |                               |           |         |                                |
|   |                             |                        |                                |                        |                               |           |         |                                |
|   |                             |                        |                                |                        |                               |           |         |                                |
|   |                             |                        |                                |                        |                               |           |         |                                |

| Route inventory for shared auto rickshaws (Survey Format 6b) – Secondary Data |              |                  |                      |                           |                      |         |               |
|---|--------------|------------------|----------------------|---------------------------|----------------------|---------|---------------|
| Route number  | Route length | Location covered | Headway<br>(minutes) | Average<br>passengers/day | Average routing time |         | Average delay |
|   |              |                  |                      |                           | Peak hour            | Average |               |
|   |              |                  |                      |                           |                      |         |               |
|   |              |                  |                      |                           |                      |         |               |
|   |              |                  |                      |                           |                      |         |               |
|   |              |                  |                      |                           |                      |         |               |
|   |              |                  |                      |                           |                      |         |               |
|   |              |                  |                      |                           |                      |         |               |
|   |              |                  |                      |                           |                      |         |               |
|   |              |                  |                      |                           |                      |         |               |
|   |              |                  |                      |                           |                      |         |               |
|   |              |                  |                      |                           |                      |         |               |
|   |              |                  |                      |                           |                      |         |               |



| Cost and Fare of Shared Autos (Survey format 6c) – Secondary Data |                       |            |                |                     |                   |                 |  |  |  |  |  |  |  |
|---|-----------------------|------------|----------------|---------------------|-------------------|-----------------|--|--|--|--|--|--|--|
| Operator  | Operation cost per km | Tax levied | Fare structure | Revenue per km (Rs) | Profit/ loss (Rs) | Fuel efficiency |  |  |  |  |  |  |  |
|   |                       |            |                |                     |                   |                 |  |  |  |  |  |  |  |
|   |                       |            |                |                     |                   |                 |  |  |  |  |  |  |  |
|   |                       |            |                |                     |                   |                 |  |  |  |  |  |  |  |
|   |                       |            |                |                     |                   |                 |  |  |  |  |  |  |  |
|   |                       |            |                |                     |                   |                 |  |  |  |  |  |  |  |
|   |                       |            |                |                     |                   |                 |  |  |  |  |  |  |  |
|   |                       |            |                |                     |                   |                 |  |  |  |  |  |  |  |
|   |                       |            |                |                     |                   |                 |  |  |  |  |  |  |  |
|   |                       |            |                |                     |                   |                 |  |  |  |  |  |  |  |



### Survey Format 7. Inventory for public transport

| Inventory for BRT Corridor (Survey Format 7a) |                 |    |                       |   |             |  |   |   |                                      |                      |
|---|-----------------|----|-----------------------|---|-------------|--|---|---|--------------------------------------|----------------------|
| Name of road                                  | Node (bus stop) |    | Width of Bus lane (m) |   | Length (km) | Bus lane location wrt road section (Median/ left side) | Type of bus infrastructure (open/close) | Bus lane Segregation tools (Kerbs/lane marking/ fences) | Type of bus stop (Staggered/ island) | Average speed (kmph) |
|   | From            | To | L                     | R |             |  |   |   |                                      |                      |
|   |                 |    |                       |   |             |  |   |   |                                      |                      |
|   |                 |    |                       |   |             |  |   |   |                                      |                      |
|   |                 |    |                       |   |             |  |   |   |                                      |                      |
|   |                 |    |                       |   |             |  |   |   |                                      |                      |
|   |                 |    |                       |   |             |  |   |   |                                      |                      |
|   |                 |    |                       |   |             |  |   |   |                                      |                      |
|   |                 |    |                       |   |             |  |   |   |                                      |                      |
|   |                 |    |                       |   |             |  |   |   |                                      |                      |
|   |                 |    |                       |   |             |  |   |   |                                      |                      |
|   |                 |    |                       |   |             |  |   |   |                                      |                      |
|   |                 |    |                       |   |             |  |   |   |                                      |                      |
|   |                 |    |                       |   |             |  |   |   |                                      |                      |
|   |                 |    |                       |   |             |  |   |   |                                      |                      |
|   |                 |    |                       |   |             |  |   |   |                                      |                      |
|   |                 |    |                       |   |             |  |   |   |                                      |                      |
|   |                 |    |                       |   |             |  |   |   |                                      |                      |
|   |                 |    |                       |   |             |  |   |   |                                      |                      |
|   |                 |    |                       |   |             |  |   |   |                                      |                      |
|   |                 |    |                       |   |             |  |   |   |                                      |                      |
|   |                 |    |                       |   |             |  |   |   |                                      |                      |
|   |                 |    |                       |   |             |  |   |   |                                      |                      |
|   |                 |    |                       |   |             |  |   |   |                                      |                      |
|   |                 |    |                       |   |             |  |   |   |                                      |                      |
|   |                 |    |                       |   |             |  |   |   |                                      |                      |
|   |                 |    |                       |   |             |  |   |   |                                      |                      |
|   |                 |    |                       |   |             |  |   |   |                                      |                      |
|   |                 |    |                       |   |             |  |   |   |                                      |                      |
|   |                 |    |                       |   |             |  |   |   |                                      |                      |
|   |                 |    |                       |   |             |  |   |   |                                      |                      |
|   |                 |    |                       |   |             |  |   |   |                                      |                      |
|   |                 |    |                       |   |             |  |   |   |                                      |                      |





| Inventory for City Bus (Survey format 7b) |             |                  |                        |   |                   |                      |                     |  |  |  |
|---|-------------|------------------|------------------------|---|-------------------|----------------------|---------------------|--|--|--|
| Route Name & Number                       | Length (km) | Name of Bus stop | Location (coordinates) |   | Bus stop capacity | Average Speed (kmph) | Near / far junction |  |  |  |
|   |             |                  | X                      | Y |                   |                      |                     |  |  |  |
|   |             |                  |                        |   |                   |                      |                     |  |  |  |
|   |             |                  |                        |   |                   |                      |                     |  |  |  |
|   |             |                  |                        |   |                   |                      |                     |  |  |  |
|   |             |                  |                        |   |                   |                      |                     |  |  |  |
|   |             |                  |                        |   |                   |                      |                     |  |  |  |
|   |             |                  |                        |   |                   |                      |                     |  |  |  |
|   |             |                  |                        |   |                   |                      |                     |  |  |  |
|   |             |                  |                        |   |                   |                      |                     |  |  |  |
|   |             |                  |                        |   |                   |                      |                     |  |  |  |
|   |             |                  |                        |   |                   |                      |                     |  |  |  |
|   |             |                  |                        |   |                   |                      |                     |  |  |  |
|   |             |                  |                        |   |                   |                      |                     |  |  |  |
|   |             |                  |                        |   |                   |                      |                     |  |  |  |
|   |             |                  |                        |   |                   |                      |                     |  |  |  |
|   |             |                  |                        |   |                   |                      |                     |  |  |  |
|   |             |                  |                        |   |                   |                      |                     |  |  |  |
|   |             |                  |                        |   |                   |                      |                     |  |  |  |
|   |             |                  |                        |   |                   |                      |                     |  |  |  |
|   |             |                  |                        |   |                   |                      |                     |  |  |  |
|   |             |                  |                        |   |                   |                      |                     |  |  |  |
|   |             |                  |                        |   |                   |                      |                     |  |  |  |
|   |             |                  |                        |   |                   |                      |                     |  |  |  |
|   |             |                  |                        |   |                   |                      |                     |  |  |  |
|   |             |                  |                        |   |                   |                      |                     |  |  |  |
|   |             |                  |                        |   |                   |                      |                     |  |  |  |
|   |             |                  |                        |   |                   |                      |                     |  |  |  |
|   |             |                  |                        |   |                   |                      |                     |  |  |  |
|   |             |                  |                        |   |                   |                      |                     |  |  |  |
|   |             |                  |                        |   |                   |                      |                     |  |  |  |
|   |             |                  |                        |   |                   |                      |                     |  |  |  |
|   |             |                  |                        |   |                   |                      |                     |  |  |  |



| Bus Terminal Survey (Survey Format 7c) |                  |            |             |           |        |
|--|------------------|------------|-------------|-----------|--------|
| Time                                   | Bus Route Number | Route Name | Type of Bus | AC/Non AC | Remark |
|  |                  |            |             |           |        |
|  |                  |            |             |           |        |
|  |                  |            |             |           |        |
|  |                  |            |             |           |        |
|  |                  |            |             |           |        |
|  |                  |            |             |           |        |
|  |                  |            |             |           |        |
|  |                  |            |             |           |        |
|  |                  |            |             |           |        |
|  |                  |            |             |           |        |

| Fleet inventory (Survey format 7d) – Secondary Data |            |   |                        |              |                     |           |         |                           |
|---|------------|---|------------------------|--------------|---------------------|-----------|---------|---------------------------|
| Owner   | Fleet size | Type of fleet (As per Urban Bus Specifications, 2013) | Fleet utilization rate | Vehicular km | Average vehicle age | Occupancy |         | Average Passenger per day |
|   |            |   |                        |              |                     | Peak hour | Average |                           |
|   |            |   |                        |              |                     |           |         |                           |
|   |            |   |                        |              |                     |           |         |                           |
|   |            |   |                        |              |                     |           |         |                           |
|   |            |   |                        |              |                     |           |         |                           |
|   |            |   |                        |              |                     |           |         |                           |
|   |            |   |                        |              |                     |           |         |                           |
|   |            |   |                        |              |                     |           |         |                           |
|   |            |   |                        |              |                     |           |         |                           |
|   |            |   |                        |              |                     |           |         |                           |
|   |            |   |                        |              |                     |           |         |                           |



**Cost and Fare (Survey format 7e) – Secondary Data**

| Operator | Operation cost per km (Rs) | Tax levied (Rs) | Type of Fare structure & Fare Structure | Revenue per km (Rs) | Profit/ loss (Rs) | Fuel efficiency |
|----------|----------------------------|-----------------|---|---------------------|-------------------|-----------------|
|          |                            |                 |   |                     |                   |                 |
|          |                            |                 |   |                     |                   |                 |
|          |                            |                 |   |                     |                   |                 |
|          |                            |                 |   |                     |                   |                 |
|          |                            |                 |   |                     |                   |                 |
|          |                            |                 |   |                     |                   |                 |
|          |                            |                 |   |                     |                   |                 |
|          |                            |                 |   |                     |                   |                 |
|          |                            |                 |   |                     |                   |                 |
|          |                            |                 |   |                     |                   |                 |
|          |                            |                 |   |                     |                   |                 |
|          |                            |                 |   |                     |                   |                 |
|          |                            |                 |   |                     |                   |                 |
|          |                            |                 |   |                     |                   |                 |

**Route Inventory (Survey format 7f) – Secondary Data**

| Route number | Route length | Location covered | Headway (minutes) | Average passengers/day | Average routing time (hour) |         | Average Delays (minute) |
|--------------|--------------|------------------|-------------------|------------------------|-----------------------------|---------|-------------------------|
|              |              |                  |                   |                        | Peak hr                     | Average |                         |
|              |              |                  |                   |                        |                             |         |                         |
|              |              |                  |                   |                        |                             |         |                         |
|              |              |                  |                   |                        |                             |         |                         |
|              |              |                  |                   |                        |                             |         |                         |
|              |              |                  |                   |                        |                             |         |                         |
|              |              |                  |                   |                        |                             |         |                         |
|              |              |                  |                   |                        |                             |         |                         |
|              |              |                  |                   |                        |                             |         |                         |
|              |              |                  |                   |                        |                             |         |                         |
|              |              |                  |                   |                        |                             |         |                         |
|              |              |                  |                   |                        |                             |         |                         |
|              |              |                  |                   |                        |                             |         |                         |
|              |              |                  |                   |                        |                             |         |                         |
|              |              |                  |                   |                        |                             |         |                         |
|              |              |                  |                   |                        |                             |         |                         |
|              |              |                  |                   |                        |                             |         |                         |



| Boarding Alighting (Survey Format 7g) |               |            |          |           |          |        |
|---------------------------------------|---------------|------------|----------|-----------|----------|--------|
| Time                                  | Bus Stop Name | Route Name | Boarding | Alighting | On Board | Remark |
|                                       |               |            |          |           |          |        |
|                                       |               |            |          |           |          |        |
|                                       |               |            |          |           |          |        |
|                                       |               |            |          |           |          |        |
|                                       |               |            |          |           |          |        |
|                                       |               |            |          |           |          |        |
|                                       |               |            |          |           |          |        |
|                                       |               |            |          |           |          |        |
|                                       |               |            |          |           |          |        |
|                                       |               |            |          |           |          |        |

| Interchange survey (Survey Format 7h) |      |      |       |                                    |       |   |       |
|---------------------------------------|------|------|-------|------------------------------------|-------|---|-------|
| Type of Interchange                   | Name | CCTV |       | Passenger Information System (PIS) |       | Parking Available for cycle / Cycle Rickshaw within 250 m |       |
|                                       |      | Y/N  | Count | Y/N                                | Count | Y/N   | Count |
|                                       |      |      |       |                                    |       |   |       |
|                                       |      |      |       |                                    |       |   |       |
|                                       |      |      |       |                                    |       |   |       |
|                                       |      |      |       |                                    |       |   |       |
|                                       |      |      |       |                                    |       |   |       |
|                                       |      |      |       |                                    |       |   |       |
|                                       |      |      |       |                                    |       |   |       |
|                                       |      |      |       |                                    |       |   |       |
|                                       |      |      |       |                                    |       |   |       |
|                                       |      |      |       |                                    |       |   |       |
|                                       |      |      |       |                                    |       |   |       |



**Survey Format 8. Landuse Survey along PT Corridor (BRT / Metro)**

| Sl. No. | Road Name | From Node | To Node | Floors | Frontage Length (m) | Basement | Floor Usage |     |     |     |     | Zonal Landuse |  |  |
|---------|-----------|-----------|---------|--------|---------------------|----------|-------------|-----|-----|-----|-----|---------------|--|--|
|         |           |           |         |        |                     |          | Ground      | G+1 | G+2 | G+3 | G+4 |               |  |  |
|         |           |           |         |        |                     |          |             |     |     |     |     |               |  |  |
|         |           |           |         |        |                     |          |             |     |     |     |     |               |  |  |
|         |           |           |         |        |                     |          |             |     |     |     |     |               |  |  |
|         |           |           |         |        |                     |          |             |     |     |     |     |               |  |  |
|         |           |           |         |        |                     |          |             |     |     |     |     |               |  |  |
|         |           |           |         |        |                     |          |             |     |     |     |     |               |  |  |
|         |           |           |         |        |                     |          |             |     |     |     |     |               |  |  |
|         |           |           |         |        |                     |          |             |     |     |     |     |               |  |  |
|         |           |           |         |        |                     |          |             |     |     |     |     |               |  |  |
|         |           |           |         |        |                     |          |             |     |     |     |     |               |  |  |
|         |           |           |         |        |                     |          |             |     |     |     |     |               |  |  |
|         |           |           |         |        |                     |          |             |     |     |     |     |               |  |  |
|         |           |           |         |        |                     |          |             |     |     |     |     |               |  |  |
|         |           |           |         |        |                     |          |             |     |     |     |     |               |  |  |
|         |           |           |         |        |                     |          |             |     |     |     |     |               |  |  |
|         |           |           |         |        |                     |          |             |     |     |     |     |               |  |  |
|         |           |           |         |        |                     |          |             |     |     |     |     |               |  |  |
|         |           |           |         |        |                     |          |             |     |     |     |     |               |  |  |
|         |           |           |         |        |                     |          |             |     |     |     |     |               |  |  |
|         |           |           |         |        |                     |          |             |     |     |     |     |               |  |  |
|         |           |           |         |        |                     |          |             |     |     |     |     |               |  |  |
|         |           |           |         |        |                     |          |             |     |     |     |     |               |  |  |
|         |           |           |         |        |                     |          |             |     |     |     |     |               |  |  |
|         |           |           |         |        |                     |          |             |     |     |     |     |               |  |  |
|         |           |           |         |        |                     |          |             |     |     |     |     |               |  |  |
|         |           |           |         |        |                     |          |             |     |     |     |     |               |  |  |
|         |           |           |         |        |                     |          |             |     |     |     |     |               |  |  |
|         |           |           |         |        |                     |          |             |     |     |     |     |               |  |  |
|         |           |           |         |        |                     |          |             |     |     |     |     |               |  |  |
|         |           |           |         |        |                     |          |             |     |     |     |     |               |  |  |
|         |           |           |         |        |                     |          |             |     |     |     |     |               |  |  |



### Survey Format 9. Freight Survey

| Date of survey: |              | Survey corridor:     |             | From:          |  |
|-----------------|--------------|----------------------|-------------|----------------|--|
| Day of survey:  |              | Direction of survey: |             | To:            |  |
| Time            | Vehicle type | Origin               | Destination | Trip frequency |  |
|                 |              |                      |             |                |  |
|                 |              |                      |             |                |  |
|                 |              |                      |             |                |  |
|                 |              |                      |             |                |  |
|                 |              |                      |             |                |  |
|                 |              |                      |             |                |  |
|                 |              |                      |             |                |  |
|                 |              |                      |             |                |  |
|                 |              |                      |             |                |  |
|                 |              |                      |             |                |  |
|                 |              |                      |             |                |  |
|                 |              |                      |             |                |  |
|                 |              |                      |             |                |  |
|                 |              |                      |             |                |  |
|                 |              |                      |             |                |  |

| Vehicle            | Code |
|--------------------|------|
| LCV                | 1    |
| 2-Axle truck       | 2    |
| 3 – Axle truck     | 3    |
| Multi axle vehicle | 4    |
| Tractor            | 5    |
| Tempo              | 6    |
| NMT                | 7    |

| Trip Frequency          | Code |
|-------------------------|------|
| Daily once (one-way)    | 1    |
| Daily twice (up & down) | 2    |
| Daily thrice or more    | 3    |
| Others                  | 4    |



**Survey Format 10. Traffic Safety – Secondary Data**

| Accident Location | Type of Accident (Fatal / Non-Fatal) | Type of vehicle Involved in the Accident | Along Road / Junction / Flyover |
|-------------------|--------------------------------------|--|---------------------------------|
|                   |                                      |  |                                 |
|                   |                                      |  |                                 |
|                   |                                      |  |                                 |
|                   |                                      |  |                                 |
|                   |                                      |  |                                 |
|                   |                                      |  |                                 |
|                   |                                      |  |                                 |
|                   |                                      |  |                                 |
|                   |                                      |  |                                 |
|                   |                                      |  |                                 |
|                   |                                      |  |                                 |
|                   |                                      |  |                                 |
|                   |                                      |  |                                 |
|                   |                                      |  |                                 |
|                   |                                      |  |                                 |
|                   |                                      |  |                                 |



## Survey Format 11. Household Survey

### General or Household interview

Socio-demographic characteristics, activity patterns and travel behaviour are inter-related. In order to effectively understand transport demand and supply, personal as well as socio-demographic characteristics such as age, gender, employment status, family size, income levels, etc. must be taken into consideration. The study of travel behaviour based on these characteristics will also help ensure that transport proposals are inclusive (that is, the benefits and costs are distributed proportionally across socio-demographic sectors). Therefore, it is essential to collect the above information while conducting the household survey for the comprehensive and inclusive mobility plan. It is possible that the income data gathered will not be representative. Therefore, for determining the income status, it is important that details on household assets are also collected during the household survey.

### Individual survey

For conducting the household survey, a travel diary method is to be used, wherein the respondent is asked to recount his or her travel behaviour on the previous day, and all trips, including the trip-chains, short distance and casual trips are noted. An analysis of travel behaviour should only draw on data collected from individuals who have been interviewed for the survey. For this sample to be truly representative, it is important to collect and include data on the travel behaviour of women, children and old people.

The household survey questionnaire can be broadly divided into two sections: a revealed preference survey<sup>41</sup> and a stated preference choice<sup>42</sup>. The revealed preference survey must include questions related to information on the household and its members as well as their choices under existing conditions, whereas the stated preference choice includes their alternative choices which may be non-existent.

Based on the identified indicators for CMP, it is necessary to collect information regarding the existing use and availability of modes, and criteria related to safety, security and cost. Also, the trip chain data should be able to capture details for multi-modal use and include information like access and egress mode, distance, travel time and cost.

---

<sup>41</sup> Revealed Preference survey is based on actual market behaviour which cannot directly predict response to new alternative. It requires large sample.

<sup>42</sup> Stated Preference survey is based on hypothetical scenarios which can elicit preferences for new alternatives. It requires smaller sample as compared to revealed preference survey.





### Travel behaviour - Household information

| Data required                                       | Description   |
|---|---|
| Personal information                                | Age   |
|   | Gender  |
|   | Education   |
|   | Occupation (to get idea about current and future travel demand/ need)           |
|   | Monthly income (in range, may be by proxy variables like household assets)      |
|   | Vehicle ownership and age of vehicle and fuel type (needed for emission factor) |
|   | Monthly expenditure on transport  |
| Trip making information                             | Trip purpose  |
|   | Trip origin   |
|   | Trip destination  |
|   | Travel distance   |
|   | Mode used   |
|   | Access mode & cost  |
|   | Egress mode & cost  |
|   | Access to Public Transport (PT) stop  |
|   | Egress from PT stop   |
|   | Distance to access PT stop  |
|   | Distance of egress PT stop  |
|   | Travel time to access   |
|   | Travel time to egress   |
|   | Average waiting time for PT (or shared auto)                                    |
|   | Total travel time   |
| Transport infrastructure rating for different modes | Perception about Safety   |
|   | Perception about security   |
|   | Perception about comfort  |
|   | Perception about cost   |

Since every city has different travel patterns and transport infrastructure, people’s responses may vary. For this reason, it is necessary to conduct pilot surveys on 1% of the sampled households, allowing for format changes (See Annexure 4)



## Part I (Revealed Preference Survey)

### 1. Reference

|   |                |                    |
|---|----------------|--------------------|
| Date:   | Surveyor name: |                    |
| Area:   | Ward No:       | Address/ Door No.: |
| Contact number of respondent (Landline and mobile): | Email id:      |                    |

### 2. Household Information

| S. No. | Name | Relation with head | Sex (M/F) | Age | Education | Main Activity (Occupation) |
|--------|------|--------------------|-----------|-----|-----------|----------------------------|
| 1      |      | 2                  | 3         | 4   | 5         | 6                          |
| 2      |      |                    |           |     |           |                            |
| 3      |      |                    |           |     |           |                            |
| 4      |      |                    |           |     |           |                            |
| 5      |      |                    |           |     |           |                            |
| 6      |      |                    |           |     |           |                            |
| 7      |      |                    |           |     |           |                            |

| Household Assets owned     | Y/N |   | Number |
|----------------------------|-----|---|--------|
|                            | Y   | N |        |
| Car                        |     |   |        |
| Scooter (M2W)              |     |   |        |
| Cycle                      |     |   |        |
| Desirable Household Assets |     |   |        |
| Phone / mobile phone       |     |   |        |
| Fridge                     |     |   |        |
| LPG Stove / Cylinder       |     |   |        |
| Cooler                     |     |   |        |
| A.C.                       |     |   |        |
| T.V.                       |     |   |        |
| Desktop / Laptop Computer  |     |   |        |

|                                   |  |  |
|-----------------------------------|--|--|
| Average Monthly Income *          |  |  |
| Monthly Expenditure on Transport* |  |  |

\*varies from city to city



| Code (Relation with Head of the Household) (2) | Education (5)                   | Activities (6-7)                          |
|--|---------------------------------|---|
| 1. Self  | 1. No school education          | 1. Salaried employment (regular waged)    |
| 2. Wife / Husband                              | 2. Primary education (Upto 8th) | 2. Daily Wages employment (casual labour) |
| 3. Son / Daughter                              | 3. Matriculation/upto 12th      | 3. Self Employed (work in h/h enterprise) |
| 4. Mother / Father                             | 4. Graduate                     | 4. Student                                |
| 5. Others                                      | 5. Others (Specify)             | 5. Unemployed                             |
|  |                                 | 6. Others - specify                       |

### 3. Vehicle Ownership in the household

|   | Present |             |      | Before 2 year |      |             |      |         |
|---|---------|-------------|------|---------------|------|-------------|------|---------|
|   | Type    | Make (Year) | Fuel | Mileage       | Type | Make (Year) | Fuel | Mileage |
| 1 |         |             |      |               |      |             |      |         |
| 2 |         |             |      |               |      |             |      |         |
| 3 |         |             |      |               |      |             |      |         |
| 4 |         |             |      |               |      |             |      |         |
| 5 |         |             |      |               |      |             |      |         |

Type: Car, Motorised two Wheeler



### 4. Choices and opinions

| How far is the nearest public transport / shared transport station from your house? |  |                         |                     |                   |  |                     |                    |                       |    |
|---|--|-------------------------|---------------------|-------------------|--|---------------------|--------------------|-----------------------|----|
| No.   | Model  | Nearest stop (distance) | Time taken to reach | Avg. Waiting time | How often do you use it in a week? (no. Of times per week) | service reliability | Safety of the mode | Cost of travel (fare) |    |
| 1   | Public Bus   |                         |                     |                   |  | Good                | Ok                 | Good                  | Ok |
| 2   | BRTS (if any)  |                         |                     |                   |  | Good                | Ok                 | Good                  | Ok |
| 3   | Shared Auto  |                         |                     |                   |  | Good                | Ok                 | Good                  | Ok |
| 4   | Do you think it is safe and convenient to walk on roads of _____ city? |                         |                     |                   | Ok   | Ok                  | Bad                | Bad                   |    |
| 5   | Are you satisfied with the way you travel in the city?                 |                         |                     |                   | Yes  | No                  |                    |                       |    |
| 6   | If No, What do you think needs to be improved?                         |                         |                     |                   |  |                     |                    |                       |    |

**Instruction for travel diary:** In the survey one trip is the round trip made by the respondent. Here a trip is divided into 6 segments, where each segment of the trip presents the additional activity taken within a trip that can be either changing mode of transport, doing interchange or additional trip purpose like buying vegetables or dropping kids. Primary trip purpose is the main trip being made by the respondent. For example, main trip is going to work while dropping child or buying vegetables on the way is the secondary trip. If number of segments in the round trip is more for a respondent then he/she can use the other table for filling up the details.

### 5. Travel Diary (Similar format will be filled for each member of the household travelling on the previous day)

| HH Member no: | Seg | Purpose <sup>43</sup> | Mode <sup>44</sup> | Start Location | Start time | Waiting Time | End Location | Day of Trip                                      |                   |               |                     |                |
|---------------|-----|-----------------------|--------------------|----------------|------------|--------------|--------------|--|-------------------|---------------|---------------------|----------------|
|               |     |                       |                    |                |            |              |              | Monday / Tuesday / Wednesday / Thursday / Friday | Travel time (min) | Distance (km) | Fare / parking cost | Trip Frequency |
| 1             |     |                       |                    |                |            |              |              |  |                   |               |                     |                |
| 2             |     |                       |                    |                |            |              |              |  |                   |               |                     |                |
| 3             |     |                       |                    |                |            |              |              |  |                   |               |                     |                |
| 4             |     |                       |                    |                |            |              |              |  |                   |               |                     |                |

### 6. Surveyor's remarks

---



---

<sup>43</sup> Trip purpose: 1-Home; 2-Work; 3-Education; 4-Access to Public transport; 5-Access to Auto Rickshaw/ Tempo; 6-Recreation; 7-Others

<sup>44</sup> Mode: 1-Car; 2-2 Wheeler; 3-Bus; 4-Auto; 5-Shared Auto; 6-Walk; 7-Bicycle; 8-Cycle Rickshaw; 9-Taxi; 10-Any others (Please Specify)



## Household Survey – Part II (Stated Preference Choice survey)

This survey format is designed to capture people’s behavior in making choices when alternative mode is available and improved. This requires providing choices to the respondents including the improved and existing alternatives. The respondents can then either choose among the given alternatives or choose an alternative within a scenario.

However, there are certain points of concern while formulating the choice set within each scenario:

- People may be biased for a certain alternative either on negative or on positive side.
- Time and cost attributes are comparatively easy to introduce and understand; however the change in safety and security parameters needs to be strongly addressed.
- It is likely that inferior modes are not considered as an available alternative for middle income and high income group.
- It is extremely important to ensure that an alternative within a choice set does not dominate as it is difficult to determine the trade-offs between different alternatives.

Stated preference choice surveys can help an analyst to identify the probability of a respondent shifting from one mode to another under varying conditions and thus estimate shifts in alternative scenarios for CMP. This requires analysing the effect of factors on the mode choice of people. Thus, in the survey various scenarios are presented to respondent that shows variations in the attributes of different modes/options and the respondent is asked to choose one preferred mode of travel in each scenario. With the help of variations in attributes of modes and respondent choice, the effect of parameters can be determined in making mode choice that can be extrapolated based on the socio-economic profile of the respondent. BIOGEME (freeware) or N-logit (licensed) can be used by the analyst to determine the co-efficient of each of the individual parameter taken into account. The survey methodology enables the analyst to understand the impact of improving infrastructure, taxation and pricing regime or introducing new choice mode in alternative scenarios.



## 7. Stated preference survey and perception study

| Description of scenarios: Choice sets (examples shown below) : sample |            |         |     |            |     |      |            |         |     |            |     |      |
|---|------------|---------|-----|------------|-----|------|------------|---------|-----|------------|-----|------|
|   | Scenario 1 |         |     | Scenario 2 |     |      | Scenario 3 |         |     | Scenario 4 |     |      |
|   | Walk       | Bicycle | Bus | MTW        | Car | Auto | Walk       | Bicycle | Bus | MTW        | Car | Auto |
| Fare  |            |         |     |            |     |      |            |         |     |            |     |      |
| Comfort   |            |         |     |            |     |      |            |         |     |            |     |      |
| Safety  |            |         |     |            |     |      |            |         |     |            |     |      |
| Travel time   |            |         |     |            |     |      |            |         |     |            |     |      |
| Parking cost  |            |         |     |            |     |      |            |         |     |            |     |      |

Based on scenarios attributes of modes, each scenario is defined by the consultants (as given in example), which is presented to the respondents one by one and asked to select mode of travel in each scenario (to be filled in table below).

### Which mode will you use for each of the following scenarios?

| Member No. | Trip Purpose             | Scenario 1 | Scenario 2 | Scenario 3 | Scenario 4 |
|------------|--------------------------|------------|------------|------------|------------|
| 1          | work trip                |            |            |            |            |
|            | shopping for daily needs |            |            |            |            |
| 2          | Going to School          |            |            |            |            |
|            | work trip                |            |            |            |            |
|            | shopping for daily needs |            |            |            |            |
| 3          | Going to School          |            |            |            |            |
|            | work trip                |            |            |            |            |
| 4          | shopping for daily needs |            |            |            |            |
|            | Going to School          |            |            |            |            |



**Example: (Vishakhapatnam Low-Carbon Mobility Plan)**

**SCENARIO 1**

| Attribute           | Car                               | Two Wheeler                        | Transit                     | Auto/Taxi                         | Bicycle   | Walk  |
|---------------------|-----------------------------------|------------------------------------|-----------------------------|-----------------------------------|---|---|
| Travel time         | More due to congestion            | More due to congestion             | 15% Less (Independent lane) | More due to congestion            | Comparable to car (Indep lane)                          | 15% less (Footpath)                                     |
| Travel Cost         | More due to increased travel time | More due to increased travel time. | Same                        | More due to increased travel time | -   | -   |
| Frequency (Transit) | -                                 | -                                  | -                           | -                                 | -   | -   |
| Comfort             | Same as today                     | Same as today                      | Same as today               | Same as today                     | No gradient, better surface, access control, more width | No gradient, indep footpath, better surface, more width |
| Safety              | Same as today                     | Same as today                      | Same as today               | Same as today                     | Better (Indep lane, Traffic speed control)              | Better (Indep lane, Traffic speed control)              |

**SCENARIO 2**

| Attribute           | Car                                | Two Wheeler                        | Transit  | Auto/Taxi  | Bicycle  | Walk   |
|---------------------|------------------------------------|------------------------------------|--|--|--|--|
| Travel time         | More due to congestion             | More due to congestion             | 15% Less (Independent lane)  | More due to congestion                             | 25 % less (Indep lane)                                   | 15% less (Footpath)                                      |
| Travel Cost         | More due to increased travel time. | More due to increased travel time. | 25 % Higher fare   | More due to increased travel time, increased fare. | -  | -  |
| Frequency (Transit) | -                                  | -                                  | 20 % More  | -  | -  | -  |
| Comfort             | Same as today for vehicle.         | Same as today                      | More due to level boarding, leg room, Standing space, Air Conditioning | Same as today                                      | No gradient, better surface, access control, more width. | No gradient, indep footpath, better surface, more width. |
| Safety              | Same as today                      | Same as today                      | Lesser Risk , lighting of stops.                                       | Same as today                                      | Better (Indep lane, Traffic speed control)               | Better (Indep lane, Traffic speed control)               |



**SCENARIO 3**

| Attribute           | Car   | Two Wheeler                        | Transit   | Auto/Taxi  | Bicycle  | Walk   |
|---------------------|---|------------------------------------|---|--|--|--|
| Travel time         | More due to congestion  | More due to congestion             | 15% Less (Independent lane)   | More due to congestion                             | 25 % less (Indep lane)                                   | 15% less (Footpath)                                      |
| Travel Cost         | More due to increased travel time, increased fuel cost, parking cost. | More due to increased travel time. | 25 % Higher fare  | More due to increased travel time, increased fare. | -  | -  |
| Frequency (Transit) | -   | -                                  | 20 % More   | -  | -  | -  |
| Comfort             | Same as today for vehicle, farther parking places.                    | Same as today                      | More due to level boarding leg room, Standing space, Air Conditioning | Same as today                                      | No gradient, better surface, access control, more width. | No gradient, indep footpath, better surface, more width. |
| Safety              | Same as today   | Same as today                      | Lesser Risk , lighting of stops.                                      | Same as today                                      | Better (Indep lane,Traffic speed control)                | Better (Indep lane,Traffic speed control)                |





## Survey Formate 12. Energy Consumption in Transport: City Level

Fuel Name: Unit: MTOE

| Sr. No. | Item             | Year 1 | Year 2 | Year 3 |
|---------|------------------|--------|--------|--------|
|         | <b>Transport</b> |        |        |        |
| 1       | Road             |        |        |        |
| 2       | Rail based       |        |        |        |
| 3       | Water based      |        |        |        |

### Instructions for filling:

1. A seperate format will be furnished for Petrol (MS), Diesel (HSD), Compressed Natural Gas (CNG), LPG and Electricity
2. Priority should be on collecting data for latest year or the year for which the information is collected for other activities
3. The information should be collected at an aggregate level from the respective Oil Companies, Electricity Utlity, Public Transport Utilities, Railways or Mass Transit Operators
4. If the information is not available at city level then district wise figures should be recorded. In order to make the information consistent with CMP planning area population should be used as a proxy.



### Survey Formate 13. Vehicle inventory – Registered Vehicles at city level

| Vehicle Type                      | Fuel   | Year 1 | Year 2 | Year 3 | Year 4 | Latest Year |
|-----------------------------------|--------|--------|--------|--------|--------|-------------|
| Two Wheelers                      | Petrol |        |        |        |        |             |
|                                   | Others |        |        |        |        |             |
| Three Wheelers                    | Petrol |        |        |        |        |             |
|                                   | Diesel |        |        |        |        |             |
|                                   | CNG    |        |        |        |        |             |
|                                   | Others |        |        |        |        |             |
| Four Wheelers                     | Petrol |        |        |        |        |             |
|                                   | Diesel |        |        |        |        |             |
|                                   | CNG    |        |        |        |        |             |
|                                   | Others |        |        |        |        |             |
| Taxis                             | Petrol |        |        |        |        |             |
|                                   | Diesel |        |        |        |        |             |
|                                   | CNG    |        |        |        |        |             |
|                                   | Others |        |        |        |        |             |
| Buses                             | Diesel |        |        |        |        |             |
|                                   | CNG    |        |        |        |        |             |
|                                   | Others |        |        |        |        |             |
| Trucks (LCV)<br>(Upto 7.5 tonnes) | Diesel |        |        |        |        |             |
|                                   | Others |        |        |        |        |             |
| Trucks (HCV)                      | Diesel |        |        |        |        |             |
|                                   | Others |        |        |        |        |             |



### Survey Formate 14. Vehicle Survey at Petrol Pump

| Type of vehicle (Tick one) | Car    | SUV      | 3 wheeler        | 2 wheeler | Bus         | Truck       | Other (Specify) |
|----------------------------|--------|----------|------------------|-----------|-------------|-------------|-----------------|
| Type of fuel (Tick one)    | Petrol | Diesel   | CNG              | LPG       | Electricity |             | Other (Specify) |
| Make                       |        |          | Model            |           |             | Year of Mfg |                 |
| Mileage                    |        | Km/litre | Odometer Reading |           |             |             | Kilometers      |

#### Instructions for filling questionnaire:

To be carried out at petrol pumps or CNG stations and preferably at stations with PUC checking so that vehicle pollution parameters can also be measured. Vehicles sampled should be in proportion to their population as per Survey format 13



### Survey Formate 15. Air Quality levels – Secondary Data

| Year |            | Date & Time of measurement | Parameters |    |     |       |        |
|------|------------|----------------------------|------------|----|-----|-------|--------|
|      |            |                            | NOx        | CO | SOx | PM 10 | PM 2.5 |
| 1    | Location 1 |                            |            |    |     |       |        |
|      | Location 2 |                            |            |    |     |       |        |
|      | Location N |                            |            |    |     |       |        |
|      | Total      |                            |            |    |     |       |        |
| 2    | Location 1 |                            |            |    |     |       |        |
|      | Location 2 |                            |            |    |     |       |        |
|      | Location N |                            |            |    |     |       |        |
|      | Total      |                            |            |    |     |       |        |
| 3    | Location 1 |                            |            |    |     |       |        |
|      | Location 2 |                            |            |    |     |       |        |
|      | Location N |                            |            |    |     |       |        |
|      | Total      |                            |            |    |     |       |        |



## Annexure 2. Stakeholder Consultation

Stakeholder consultation is an important exercise for various reasons:

- a) **Understanding the city:** It is necessary to engage with stakeholders who work in the city. Ground experience of the stakeholders with the city is valuable and must be captured. This exercise will help us understand not just the characteristics of the city but also help us understand the main bottlenecks and strengths of the city. By understanding the limitations within which the stakeholders work, we will be able to develop more relevant scenarios for the city and make better recommendations.
- b) **Stakeholder consultations:** It has been widely recognized as an important exercise in recent times. The top-down approach, where recommendations are made to a city without involving stakeholders in the deliberation process and using its know-how, has been widely criticised. It is now recognized that each city has its unique character. The recommendations made, have to suit the unique circumstances under which the city functions.
- c) **The scope of work of each organisation:** There are a number of agencies that operate in a city. Sometimes, multiple agencies will be involved in the same area. For example: Construction and maintenance of roads in a city won't fall under the jurisdiction of a single agency. A number of agencies are involved in that process. There is usually a clear demarcation of each agency's scope of work and therefore understanding the exact jurisdiction of each agency is important. This will help in understanding the exact tasks that each organisation is responsible for and also identifying areas where there is an overlap of tasks and responsibilities.
- d) **Developing alternative scenarios:** CMP will involve developing alternative scenarios of urban transport. The difference between the alternatives will be differences in policy; institutional framework; transport plans of the city; technological innovations and other such details. Stakeholder consultation will help in building these alternative scenarios.
- e) **Building a rapport with the city:** By engaging with the stakeholders, a rapport will be built with the city. This is vital because recommendations made in the CMP will need to be implemented. Having a rapport with the city will ensure that the recommendations are smoothly implemented and problems and bottlenecks are minimized in the implementation stage.
- f) It is to be noted that certain stakeholders may not contribute to the creation of CMP but could be powerful enough to hinder the implementation. Engaging these stakeholders, keeping them regularly in the loop of the project and taking some of their recommendations into consideration will help in ensuring maximum support from the city.

### Identifying Stakeholders

Stakeholders will include the following:

- i. Government Bodies like Municipal corporations, Development Authorities, Public Works Departments, Traffic Police, Transport Department, Environment Pollution Control Authority (EPCA), Environment Department, Cantonment Board, Transport Corporations, etc.



- ii. Experts in the field of transport from Academic Institutes and Research bodies and Consultants or practitioners in the field.
- iii. Non-governmental organisations (NGOs)/ Civil Society Organisations (CSOs)
- iv. Elected Representatives from city (Ward councillors/ Corporators), state (MLAs, Transport minister) or Centre (MP).
- v. Operators like auto rickshaw unions, private bus operators.

### Classifying stakeholders on the basis of their role in transport

- a) **Organisations or individuals responsible for making decisions regarding transport.** These organisations could be involved either at city-level planning of transport or framing policies or in transport operations. That is, government organisations for which transport is one of the primary focus and thus they are directly involved.
- b) **Organisations or individuals who are not part of the government but are directly involved in the transport operations in the city.** This could include auto rickshaw unions, taxi drivers association, etc. This group could also include Private players who are involved with the government in various transport based PPP operations like operation of buses, toll roads, etc.
- c) **Organisations or individuals (government or non-government) whose activities tend to shape the transport needs and demands of the city.** This will include large industrial units, urban development authorities, ports, railways, etc.
- d) **Organisations and individuals (government or non-government) who hold prominent positions are important opinion makers in the city.** This will include the Press; Universities, colleges and other educational institutes; popular NGOs and other popular representative organisations like Confederation of Indian Industry.

Another way of classifying the stakeholders is on the basis of their location (centre, state and city level) and roles in the transport system (planning & policy, infrastructure, operations and monitoring /evaluation). A classification done for Visakhapatnam during the preparation of LCMP is provided in Table below.

#### Institutional framework for urban and regional transport functions for Vishakapatnam

| Mode              | Hierarchy | Planning & Policy | Infrastructure | Operations     | Monitoring & Evaluation |
|-------------------|-----------|-------------------|----------------|----------------|-------------------------|
| Private Motorised | Centre    | HPCL              | NHAI           |                |                         |
|                   | State     | VUDA              |                | Traffic Police | RTA, APPCB              |
|                   | City      |                   | GVMC           |                |                         |
| Non-Motorised     | Centre    |                   | NHAI           |                |                         |
|                   | State     | VUDA              |                | Traffic Police |                         |
|                   | City      |                   | GVMC           |                |                         |

| Mode          | Hierarchy | Planning & Policy    | Infrastructure             | Operations                    | Monitoring & Evaluation |
|---------------|-----------|----------------------|----------------------------|-------------------------------|-------------------------|
| IPT           | Centre    | HPCL                 | NHAI                       |                               |                         |
|               | State     | VUDA                 |                            | IPT Operators, Traffic Police | RTA, APPCB              |
|               | City      |                      | GVMC                       |                               |                         |
| City Bus      | Centre    | HPCL                 | NHAI                       |                               |                         |
|               | State     | VUDA, APSRTC         | APSRTC                     | APSRTC, Traffic Police        | RTA, APPCB              |
|               | City      |                      | GVMC                       |                               |                         |
| BRT           | Centre    | HPCL                 |                            |                               |                         |
|               | State     | VUDA                 |                            | APSRTC, Traffic Police        | VUTCL                   |
|               | City      | GVMC                 | GVMC                       |                               |                         |
| Intercity Bus | Centre    | HPCL                 | NHAI                       |                               |                         |
|               | State     |                      | APSRTC, AP R&B (PWD) Dept. | APSRTC                        |                         |
|               | City      |                      |                            |                               |                         |
| Railways      | Centre    | East Coast Railway   | East Coast Railway         | East Coast Railway            |                         |
|               | State     |                      |                            |                               |                         |
|               | City      |                      |                            |                               |                         |
| Airport       | Centre    | AAI                  | AAI                        | Airlines                      | DGCA                    |
|               | State     |                      |                            |                               |                         |
|               | City      |                      |                            |                               |                         |
| Port          | Centre    | Ministry of Shipping | Ministry of Shipping, VPT  | VPT                           |                         |
|               | State     |                      |                            |                               |                         |
|               | City      |                      |                            |                               |                         |
| Goods         | Centre    |                      | NHAI                       |                               |                         |
|               | State     | VUDA                 |                            |                               |                         |
|               | City      |                      | GVMC                       | Private Operators             |                         |

HPCL – Hindustan Petroleum Corporation Ltd.

VUDA – Vishakhapatnam Urban Development Authority

NHAI – National Highway Authority of India

GVMC – Greater Vishakhapatnam Municipal Corporation

APSRTC- Andhra Pradesh State Road Transport Corporation

APR&B (PWD) – Andhra Pradesh Road & Buildings Public Works Department

RTA – Regional Transport Authority

APPCB – Andhra – Andhra Pradesh Pollution Control Board

VUTL – Vishakhapatnam Urban Transport Company Ltd.

VPT – Vishakhapatnam Port Trust



## Managing Stakeholders

Stakeholder management is important to ensure a long-term involvement in planning and implementation of CMP. The stakeholders identified should be classified according to their attitude towards sustainable transport initiatives as well as their level of power or influence on them. Such an exercise will help in grouping similar stakeholders together. ‘Ecology of actors’ framework used for mapping and managing the stakeholders is shown in the Figure on the right.

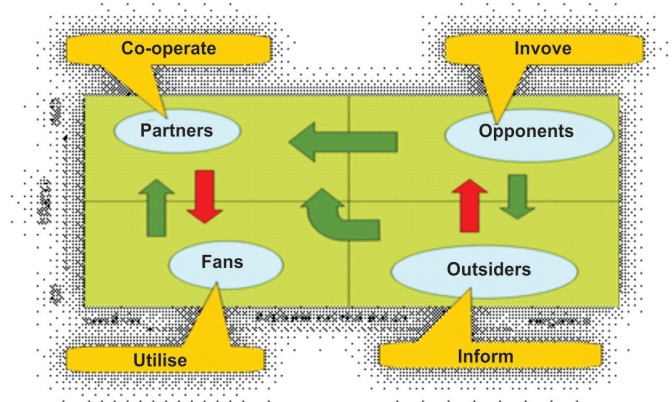

**Ecology of Actors Framework for Managing Stakeholders<sup>45</sup>**

This framework classifies stakeholders into four categories depending on their power/ influence levels and their attitude towards sustainable transport. These four groups are as follows:

- a) Partners: High on influence/power and positive attitude;
- b) Fans/ weak partners: Low on Influence and positive attitude;
- c) Opponents: High on power/ influence and negative attitude; and
- d) Outsiders/ weak opponents: Low on power/Influence and negative attitude.

<sup>45</sup> Lake Sagaris's Presentation: "Inclusive Planning for Good, Just, Liveable Cities", March 2012 (Tom Godefrooij, I\_CE/ Brakant Planners, The Netherlands)



### Annexure 3. List of NUIS Scheme Towns

| Sl. No. | Town             | State                     |
|---------|------------------|---------------------------|
| 1       | Port Blair       | Andaman & Nicobar Islands |
| 2       | Adilabad         | Andhra Pradesh            |
| 3       | Dharmavaram      | Andhra Pradesh            |
| 4       | Madanapalle      | Andhra Pradesh            |
| 5       | Nalgonda         | Andhra Pradesh            |
| 6       | Srikakulam       | Andhra Pradesh            |
| 7       | Tadepaligudem    | Andhra Pradesh            |
| 8       | Along            | Arunachal Pradesh         |
| 9       | Daporijo         | Arunachal Pradesh         |
| 10      | Dibrugarh        | Assam                     |
| 11      | Nagaon           | Assam                     |
| 12      | Silchar          | Assam                     |
| 13      | Tezpur           | Assam                     |
| 14      | Tinsukia         | Assam                     |
| 15      | Arrah            | Bihar                     |
| 16      | Bhagalpur        | Bihar                     |
| 17      | Darbhanga        | Bihar                     |
| 18      | Muzaffarpur      | Bihar                     |
| 19      | Patna            | Bihar                     |
| 20      | Chandigarh       | Chandigarh                |
| 21      | Bhilai Nagar     | Chhattisgarh              |
| 22      | Bilaspur         | Chhattisgarh              |
| 23      | Durg             | Chhattisgarh              |
| 24      | Korba            | Chhattisgarh              |
| 25      | Raipur           | Chhattisgarh              |
| 26      | Silvassa         | Dadra & Nagar Haveli      |
| 27      | Daman            | Daman & Diu               |
| 28      | Cuncoim          | Goa                       |
| 29      | Curchorem Cacora | Goa                       |
| 30      | Mapusa           | Goa                       |
| 31      | Margao           | Goa                       |
| 32      | Mormugao         | Goa                       |
| 33      | Bhavnagar        | Gujarat                   |
| 34      | Jamnagar         | Gujarat                   |
| 35      | Nadiad           | Gujarat                   |
| 36      | Rajkot           | Gujarat                   |
| 37      | Surat            | Gujarat                   |



| Sl. No. | Town              | State            |
|---------|-------------------|------------------|
| 38      | Vadodara          | Gujarat          |
| 39      | Faridabad         | Haryana          |
| 40      | Hisar             | Haryana          |
| 41      | Karnal            | Haryana          |
| 42      | Panipat           | Haryana          |
| 43      | Rohtak            | Haryana          |
| 44      | Dharamsala        | Himachal Pradesh |
| 45      | Mandi             | Himachal Pradesh |
| 46      | Nahan             | Himachal Pradesh |
| 47      | Shimla            | Himachal Pradesh |
| 48      | Solan             | Himachal Pradesh |
| 49      | Anantnag          | Jammu & Kashmir  |
| 50      | Baramula          | Jammu & Kashmir  |
| 51      | Sopore            | Jammu & Kashmir  |
| 52      | Achabal           | Jammu & Kashmir  |
| 53      | Akhnoor           | Jammu & Kashmir  |
| 54      | Bandipura         | Jammu & Kashmir  |
| 55      | Beerwah           | Jammu & Kashmir  |
| 56      | Bijehara          | Jammu & Kashmir  |
| 57      | Budgam            | Jammu & Kashmir  |
| 58      | Dakshum           | Jammu & Kashmir  |
| 59      | Ganderbal         | Jammu & Kashmir  |
| 60      | Kistwar           | Jammu & Kashmir  |
| 61      | Kokarnag          | Jammu & Kashmir  |
| 62      | Kulgam            | Jammu & Kashmir  |
| 63      | Poonch            | Jammu & Kashmir  |
| 64      | Qazigund          | Jammu & Kashmir  |
| 65      | Rajouri           | Jammu & Kashmir  |
| 66      | Ramban            | Jammu & Kashmir  |
| 67      | Samba             | Jammu & Kashmir  |
| 68      | Sopian            | Jammu & Kashmir  |
| 69      | Tral              | Jammu & Kashmir  |
| 70      | Udhampur          | Jammu & Kashmir  |
| 71      | Uri               | Jammu & Kashmir  |
| 72      | Vijaypur          | Jammu & Kashmir  |
| 73      | Bokaro Steel City | Jharkhand        |
| 74      | Dhanbad           | Jharkhand        |
| 75      | Jamshedpur        | Jharkhand        |



| Sl. No. | Town                | State          |
|---------|---------------------|----------------|
| 76      | Mango               | Jharkhand      |
| 77      | Ranchi              | Jharkhand      |
| 78      | Bellary             | Karnataka      |
| 79      | Bidar               | Karnataka      |
| 80      | Bijapur             | Karnataka      |
| 81      | Davanagere-Harihara | Karnataka      |
| 82      | Kolar               | Karnataka      |
| 83      | Raichur             | Karnataka      |
| 84      | Alappuzha           | Kerala         |
| 85      | Kollam              | Kerala         |
| 86      | Kozhikode           | Kerala         |
| 87      | Palakkad            | Kerala         |
| 88      | Thrissur            | Kerala         |
| 89      | Kavaratti           | Lakshadweep    |
| 90      | Dewas               | Madhya Pradesh |
| 91      | Gwalior             | Madhya Pradesh |
| 92      | Jabalpur            | Madhya Pradesh |
| 93      | Sagar               | Madhya Pradesh |
| 94      | Satna               | Madhya Pradesh |
| 95      | Ujjain              | Madhya Pradesh |
| 96      | Aurangabad          | Maharashtra    |
| 97      | Bhiwandi            | Maharashtra    |
| 98      | Nashik              | Maharashtra    |
| 99      | Pimri Chinchwad     | Maharashtra    |
| 100     | Pune                | Maharashtra    |
| 101     | Thane               | Maharashtra    |
| 102     | Imphal              | Manipur        |
| 103     | Kakching            | Manipur        |
| 104     | Jowai               | Meghalaya      |
| 105     | Tura                | Meghalaya      |
| 106     | Champhai            | Mizoram        |
| 107     | Lunglei             | Mizoram        |
| 108     | Dimapur             | Nagaland       |
| 109     | Mokokchung          | Nagaland       |
| 110     | Baleshwar           | Orissa         |
| 111     | Baripada            | Orissa         |
| 112     | Brahmapur           | Orissa         |
| 113     | Cuttack             | Orissa         |



| Sl. No. | Town                      | State         |
|---------|---------------------------|---------------|
| 114     | Raurkela                  | Orissa        |
| 115     | Sambalpur                 | Orissa        |
| 116     | Kraikal                   | Pondicherry   |
| 117     | Amritsar                  | Punjab        |
| 118     | Bhatinda                  | Punjab        |
| 119     | Jalandhar                 | Punjab        |
| 120     | Ludhiana                  | Punjab        |
| 121     | Pathankot                 | Punjab        |
| 122     | Patiala                   | Punjab        |
| 123     | Bandikui                  | Rajasthan     |
| 124     | Bijainagar-Gulabpura      | Rajasthan     |
| 125     | Dungarpur                 | Rajasthan     |
| 126     | Karauli                   | Rajasthan     |
| 127     | Makrana                   | Rajasthan     |
| 128     | Sawai Madhopur            | Rajasthan     |
| 129     | Rango                     | Sikkim        |
| 130     | Singtam                   | Sikkim        |
| 131     | Namchi                    | Sikkim        |
| 132     | Jorethang-Naya Bazar      | Sikkim        |
| 133     | Geyzing-Pelling           | Sikkim        |
| 134     | Mangan                    | Sikkim        |
| 135     | Pakyong                   | Sikkim        |
| 136     | Rongli                    | Sikkim        |
| 137     | Soreng                    | Sikkim        |
| 138     | Ravongla                  | Sikkim        |
| 139     | Dharmanagar               | Tripura       |
| 140     | Radhakishorepur (Udaipur) | Tripura       |
| 141     | Kailashahar               | Tripura       |
| 142     | Khowai                    | Tripura       |
| 143     | Allahabad                 | Uttar Pradesh |
| 144     | Ghaziabad                 | Uttar Pradesh |
| 145     | Kanpur                    | Uttar Pradesh |
| 146     | Lucknow                   | Uttar Pradesh |
| 147     | Meerut                    | Uttar Pradesh |
| 148     | Varanasi                  | Uttar Pradesh |
| 149     | Durgapur                  | West Bengal   |
| 150     | Kutli                     | West Bengal   |
| 151     | Burdwan                   | West Bengal   |
| 152     | Karagarpur                | West Bengal   |



## Annexure 4. Data Collection Approach – Methodology and Sources

### Sampling Methodology for Primary Surveys

Primary surveys are administered for sampled zones; stratified sampling<sup>46</sup> is recommended for collecting the required data. The city can be divided into six to eight broad zones, based on land use patterns and distance from the city core area or central business district (CBD) to capture variation in infrastructure and the socio-economic profile of city residents.

#### Broad categories of zones

| Distance from CBD | Residential | Slums | Commercial/ Industrial |
|-------------------|-------------|-------|------------------------|
| 0 -1 km           |             |       |                        |
| 1 – 3 km          |             |       |                        |
| 3 – 5 km          |             |       |                        |
| more than 5 km    |             |       |                        |

### Sampling technique for household surveys

CMPs need to account for different cross sections of society, and thus a representative sample survey from all levels of society is necessary. It is also important to distribute the sample geographically. If NUIS and property tax data is already available for the city, the building footprint and its attribute can be used for the sampling exercise.

If NUIS and property tax data is not available then from the broad zone categories defined in the Table above, sample TAZs are selected for surveying and collecting data. A stratified sample is done based on the socio-economic profile of the city so that it is significant at the level of 95% confidence interval level.

#### Sample sizes for household survey<sup>47</sup>

| Population of study area | Sample size (%) |
|--------------------------|-----------------|
| 1.5 – 3.0 lakh           | 3 – 5 %         |
| 3.0 – 5.0 lakh           | 2 – 3 %         |
| 0.5– 10.0 lakh           | 1.5 – 2 %       |
| > 10.0 lakh              | 1 – 1.5 %       |

<sup>46</sup> A geographically stratified random sampling scheme can be used to ensure an adequate representation of key subgroups of population / geographic areas. In a given sample, stratification may be done by city, planning district, or any other appropriate geographic jurisdiction. In deciding the stratification, the main goal is to divide the study area into relatively homogenous groups. A simple random sample of elements is then chosen from each group. Once the surveying is complete, weights are developed for each group so that the data for all groups may be homogenized.

<sup>47</sup> See Development of Toolkit under “Sustainable Urban Transport Project” Travel Demand Modelling, MoUD (2013), Table 4-4 Details of travel demand surveys, sample frame for household survey, Pg 35.



## Sampling method note

The purpose of the household surveys is to quantify and analyze the travel characteristics of people belonging to various socio-economic groups in the city. Besides, the household level survey will also help in modelling origin-destination of trips, vehicle emissions and stated preferences etc. This survey mainly captures the existing conditions of the respondents and their preferences or choices as stated by them.

### Sampling

Urban areas are large and highly diverse. An assessment of the full universe for an appropriate sampling is itself a hard task, given that many of the available data from the census tracks, which can be used for getting the characteristics of the universe, are not available in the public domain. Secondly, for such large universes, a stratified systematic sampling is required provided we are able to identify the strata from the available data set. Thereafter the task is to decide the strata for survey and then identify samples within each stratum. The more diversified the sample, the more the strata identified and the better the identification of strata more representative the sample is. We discuss below the process of identifying different strata and sub-strata in a city and then selecting sample households for detailed structured questionnaire surveys.

#### 1. Stratifying the city by spatial (geographic) units

The urban areas need to be selected for survey on the basis of unbiased spatial representation. The first task is to identify the spatial units from within which the second level of stratification is done. Based on the demographic characteristics and delineation of traffic analysis zones (TAZs), the first level of strata can be identified. At the first level, the city can be divided into different spatial units based on either population density or delineated TAZ in case the latter data is available. Since the data of TAZs is not available, the demographic data has to be used.

For the use of demographic data, the hypothesis is: 'people of same economic and social characteristics congregate in the same area' and that densities indicate economic characteristics of a neighbourhood. Population census gives the demographic characteristics and from among the available data, four sets can be of use in combination or individually (i) housing characteristics – kutcha housing representing the poor and pucca housing representing the rich and the middle classes (ii) female literacy rate – higher the income higher is the female literacy, (iii) density and (iv) proportion of Scheduled Castes/ minorities.

The census has the data for each household but when the data is given out, it is by wards of the city. A ward can be used as a basic unit of spatial stratification, if the wards are not too large. If the wards are too large then we have to go at the sub-ward level and we need to find out from the Urban Local Body (ULB) if it has this data. If it is not available with the ULB then one can use the data of the enumeration block of the census, which is a data aggregated for about 100 to 120 households. This data can be plotted on the map to get the spatial divisions and then pick up the strata for sampling. This is the First Stage Stratification. Some of the cities now have a Geographic Information System (GIS) data with building footprints and from mapping these; we can identify homogenous zones as First Stage Strata (FSS). Since the demographic data are available at a micro spatial unit level, these data can be used to prepare an index, which is mapped on a GIS base to identify zones of different economic strata.



Scheduled caste dominated zones can also be identified thus and these can be superimposed on the economic strata to identify different zones/ spatial units with different economic and social characteristics. The challenge will remain to identify spatial units with concentration of minority groups, if they are in substantial numbers. Many Indian cities are segmented by religion as well and through discussions with key informants and physically moving across the city, the spatial units where minorities are concentrated can be identified.

## **2. Second stage strata for transport studies**

If the TAZs are available then that can be used. If not then it is assumed that spatial units located at different distance from the city centre would have different travel characteristics' and hence second level of stratification can be based on different distance from the city centre. In Indian cities, informality allows people to stay near their work place if they cannot afford a formal house and hence industrial workers tend to stay in or near industrial areas and loaders-unloaders tend to stay near the railway station or wholesale markets. Distance from the city centre can be interpreted as distance from the work centres and hence zones can be delineated based on the land-use. The city would definitely have a land-use map, and through physical movement in the city by the researchers, a broad idea of the city's employment centres can be obtained. This can be used for preparing zones. Subsequently a further stratification can be done based on location by distance from the centre, e.g. core, intermediate zone, periphery and outer periphery depending on the size of the city and land-use structure (or morphology) of the city.

To summarize, the urban areas in a city can be selected representing following criteria to represent unbiased spatial distribution:

- I. Spatial distribution determined by administrative units (based on demographics) such as municipal wards to get spatial units representing different economic and social groups.
- II. Landuse structure or city's morphology
- III. Distance from the city centre (Core city, intermediate, peripheral and outer periphery)
- IV. Spatial distribution determined by traffic-analysis zones if available

While ensuring unbiased spatial distribution, it is important to ensure that various socio-economic groups are also well-represented as part of these samples. Within each spatially representative area/zone/cluster of zones, the low-income group housing or slum households should be included in the sample. The sample of slum households in each selected zone/area should be at least as much as the percentage of population residing in slums at the city level (or at the zone level if data at zonal level is available).

## **3. Identifying settlements for survey**

Once the spatial zones/units have been identified for survey, settlements within them have to be identified. At this stage, housing typology can be used for making the decision. The housing typologies are: (i) slums and chawls (ii) independent bungalows, (iii) twin bungalows, (iv) low rise apartments and (v) high rise apartments. Low-rise apartments tend to house lower middle income groups whereas high rise apartments tend to house higher middle income to high income groups. Bungalows tend to house high income groups and elites. After



selecting the settlement, either random sampling using random numbers or systematic sampling (every nth house depending on the sample size required for the settlement) can be deployed. If the settlement is large, as some of the slum or housing board colonies may be then clusters can be identified in the settlement to capture the homogenous groups within a settlement after which random or systematic sampling method can be applied.

Within the selected area, it should be ensured that all socio-economic groups are well-represented. While surveying in low-income housing or slums, it should be ensured that housing typologies (i.e. kutcha houses) and socially vulnerable groups (i.e. female-headed households). In slums, care must be taken to pick up samples of households living in kutcha housing to be able to get a sample of the poorest of the poor.

## Logistics

- The h/h surveys should be conducted in the household settings answered by one adult member of the family.
- There should be a team of two senior people to monitor the survey teams.
- Ideally, data-entry of the surveys should be simultaneously done so that in case of missing information or errors, the surveyor can be sent back again for the survey.
- This is a generic sampling guide for the purpose of transport related household survey in Indian cities. Indian cities have diverse set of data and situations, the researchers can use this note as a guide while taking cognizance of the diverse situation in different cities based on their own perceptions and intuition.

## Instruction to Surveyors

A detailed workshop should be conducted with surveyors to explain the purpose of the surveys and the data that needs to be collected. Specific instructions include the following:

1. The trips taken and travel needs for the last day are to be recorded. This will include all multiple or single trips made during the last day by every member of the household.
2. The access and egress part of the trips needs to be recorded if public transport or para-transit modes of transport are used. This means there will be a minimum of three segments for each trip: the access trip, the line-haul trip and the egress trip. Boarding and alighting time, boarding and alighting stations, access and egress distance and access and egress modes will all be included. If transfers are made to change the bus or other route it should be defined as a separate segment.
3. Surveyors need to record parking charges if respondent or person making trip is using private modes of transport (including bicycle).

## Cross-Checks and Continuous Monitoring

Survey forms should be randomly checked at regular intervals to keep track of the quality of information being collected. Also, cross checks are required regarding the type of information collected. It is advised that for survey





personnel, a suitable number of supervisors are provided by the consultant. A second way of cross checking is triangulation for data so that some data are collected using different approaches to see the differences.

### Sampling technique for collecting data related to infrastructure

In order to prepare an infrastructure inventory, information about the existing level of service and infrastructure type is to be collected for non-motorised transport, para transit, public transport and personal motor transport. Data on roads and infrastructure type is collected for three categories of roads, based on the ROW and the purpose served: arterial or sub-arterial; collector roads; and local roads. The road inventory for the entire city is developed on GIS platform and data is collected using a sample of road amenities and facilities. From each of the broad category of zones defined earlier, sample TAZs are selected based on their spatial distribution. **From each of the selected TAZs, a detailed survey is conducted on minimum 50% of the randomly selected roads covering arterial, collector and local roads.** Based on the land use characteristic and spatial distribution of TAZs, a relationship can be drawn to extrapolate the infrastructure type.

### Sampling technique for freight

Both motorised and non-motorised vehicles carrying goods coming into the city and moving within city needs to be surveyed. This can be done at sampled outer cordons and cordon points where these vehicles enter the core city area. For example, in case of Visakhapatnam, five out of twenty sampled intersections were selected for collecting data related to freight movement in the city. Of these three were outer cordons while other two were entry points to the core-city area. 16 hour turning movement counts have been carried out at each of these intersections on a typical working day. Along with origin and destination of the trips; the survey also needs to capture type of vehicle used and commodity carried (Survey format 9)

### Sampling Methodology for the Petrol Pump Survey

The choice of petrol pumps should be based on convenience sampling but preferably in different areas of the city. **Random vehicles are surveyed in proportion of 33% cars, 33% two wheelers, 10% three wheelers, 12% buses and 12% trucks to develop a confidence level at 95% significance.** Simultaneously, a crosscheck on the composition of vehicles (age and type) needs to be done as per the number of registered vehicles. **A sample of at least 3,000<sup>48</sup> vehicles** (two-wheelers, cars, buses, autos and trucks) should be collected to cover the sufficient number of vehicles of different vintage.

---

<sup>48</sup> The sample size of 3000 is recommended based on surveys carried in Delhi, Vishakhapatnam, Rajkot and Udaipur to achieve statistically significant sample for each vehicle category for different vintage



## Annexure 5. Four-Step Modelling

### Model Framework (Four Step Modelling)

The four-step model approach for CMP needs to account for different social groups and gender (See the Figure below) and for all modes of transport including NMT, para-transit and public transport and this is slightly different from the conventional four-step modelling where there is no differentiation in terms of socio-economic groups and gender, where the focus is mainly on motorised transport. Modeling software’s like QuantumGIS, ArcGIS, TransCAD, CUBE, VISUM, EMME, OmniTrans, etc. can be used to create the travel demand model of the city. However these softwares are designed primarily to model motorised modes like cars, two-wheelers and buses. Visum is the only software among these that has specific modules on environment & emission modelling, and modelling for NMT (PuTAux) as well as public transport modelling. Hence adequate care should be taken in specifying the modelling parameters to suit the softwares for cycles. Various stages of the modelling procedure have been explained in the following sections.

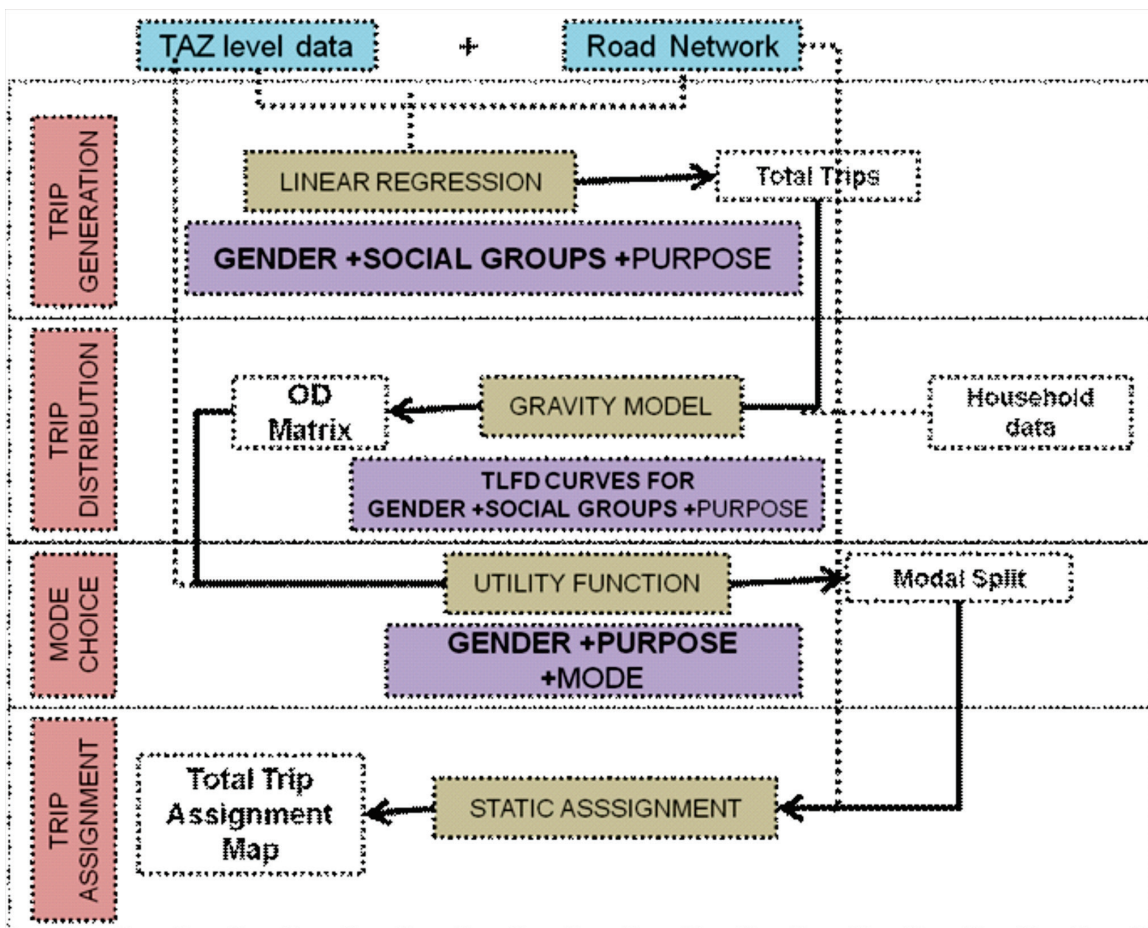

Four-Step Model Framework



The base year travel demand model is required to replicate the road network and travel patterns of the city in modeling software and to test for various short-term measures that can be taken to improve the existing transportation systems. The following table gives the input parameters and their data sources used for developing the base year model.

### Modeling components and input sources

| Model Component           | Input Source  |
|---------------------------|---|
| Traffic Analysis Zone Map | Derived from Ward Map   |
| Road Network              | Derived from Primary Data collected for road inventory & Link speeds and secondary data on road widths<br>(It can also be derived from open street maps, if VISUM software is used for modeling. Open street maps helps in incorporating all the road characteristics). |
| Trip Production Patterns  | Household Interview Data and census   |
| Trip Attraction Patterns  | Land Use Data from Master Plan and Building wise usage type from Property Tax Database  |
| Trip Distribution         | Trip length distribution patterns from Household Interview data to calibrate the <b>Gravity Model</b>   |
| Base Year Mode Shares     | Household Interview Data  |
| Trip Assignment           | Traffic Volume Counts used for network calibration  |

#### Trip Generation

Trip generation involves estimating the total number of trips produced and attracted to each TAZ. Trip production is dependent on socio-economic characteristics of households within the TAZ while trip attraction depends on the land-use type of the TAZ as explained below.

#### Trip production

Household interview data is normally used to estimate the trip production trends for various types of households using the following steps:

- Purpose-wise trips (eg., work, school/college, social, recreation, etc) produced in each household are derived as a function of the socio-economic attributes of the household like household size, income and vehicle ownership.
- Total number of households in each TAZ is derived from the census data or the property tax database and its total households and number of trips produced are estimated.
- The socio-economic characteristics of each TAZ are derived from the HH Interview data.
- If detailed household level data is not available, TAZ level data and parameters like TAZ population, employment opportunities etc. are used to derive the productions for each TAZ.

#### Trip Attraction

The number of trips attracted to each TAZ is estimated in this step. The attractiveness of a zone is a function of



the type of land-use of that zone. For example residential land uses produce trips while commercial, institutional and industrial areas typically attract trips. Hence the existing land use mix is considered as the critical variable in determining the trips attracted to each TAZ. Land use data at the city level is provided by the Master plan of the city, but they are only indicative as the land use allocation in the master plan and the actual usage of land use is observed to be varying widely in practice.

The Property tax data from the municipal corporations maintain building wise land use type and its plinth area. Types of land use in the buildings include: Residential, Commercial, Educational, Industrial, Public Use, Shops, Hospital, Cinema/Pub Entertainment, Others. Except residential, all other land use types attract trips. **Hence, the total plinth area of each type of attracting land uses can be calculated and used as a measure of attractiveness of the TAZ.**

**Purpose-wise trips attracted to each zone from the household interviews is correlated with land use types in each TAZ, using multiple linear regression technique to derive the relation between the trips attracted and the land uses of the TAZ.** Based on these equations, the number of trips attracted to each zone is re-calculated using the equations. This however only gives the number of trips at the scale of the sample size of data, since the sample trips are used for deriving the equation. Therefore these attractions are used as the relative attractiveness of each zone. **The attractions of each zone are then up scaled proportionally to the total attractions based on the total trips produced for each purpose.**

### **Trip Distribution**

Trip distribution is used to derive the Origin-Destination (OD) matrix from the Production Attraction (PA) table prepared in trip generation. Gravity Method is generally adopted for trip distribution. In this method trips between zone i and zone j ( $T_{ij}$ ) are distributed in proportion to the number of trips produced in i, number of trips attracted in j and in the inverse proportion of the impedance between these zones i.e. travel time, travel cost, relative safety etc.

$$T_{ij} = P_i [A_j F_{ij} / \sum A_j F_{ij}]$$

Where,

$T_{ij}$  = trips produced at i and attracted at j,

$P_i$  = total trip production at i,

$A_j$  = total trip production at j,

$F_{ij}$  = (friction factor) or computed using the TLF curves

i = origin zone,

j = destination zone

Trip Distribution can be carried out purpose wise or mode-wise based on city specific characteristics. (e.g.,) Trip length distribution should be observed both purpose wise and mode wise, and whichever parameter has more clearly defined trip length distributions should be selected for distribution. **If the type of mode is affecting trip length more, mode share split can be carried out before the trip distribution.** The following is the step wise procedure.



- The purpose wise peak hour trips are added up to get the total trips produced and attracted to each TAZ.
- The TAZ wise mode-share values can be derived from the HH Interview data and applied to the PA table to get the mode-wise PA table for all zones.
- Current users: The mode share of public transport and cycles in each TAZ is derived from the household interview data and is used to derive the PA table for current public transport and cycling trips. The PA table can be for the peak hour or for the entire day based on the study requirements.
- Potential users: All the trips in the city form the potential public transport and cycle users in the city and it is important to model these trips in parallel to estimate their potential shift to public transport and cycles respectively.
- One of the features of the four-stage demand modeling process is that only the inter-zonal trips are considered for assignment. Hence, the proportion of intra-zonal trips in each TAZ is calculated from the HH Interview data and these trips are excluded from the demand modeling process.
- The PA table containing inter-zonal public transport trips is used as the input for trip distribution.

For public transport trips, the generalized cost is considered as impedance which is worked out based on time taken for access, waiting, line haul, transfer, line haul and egress, and dis-utility of each of these in monetary terms.

### **Mode Choice**

Mode choice models should be developed for all modes of transport including public transport and para-transit modes. As discussed in Task 2-2 TAZ size for modelling thus needs to be small enough to cater to walk, bicycle trips and account for impact of access/egress trips on public transport.

### **Mode choice equations**

These are computed based on revealed and stated preference of individuals surveyed in the HH survey. A Multi-nominal logit or Nested logit models or any other logit function were run to achieve the mode choice equations. As stated mode choice is the dependent variable and socio-demographics of the individual, built form indicators at the trip's origin and end and travel cost are the independent variables in the equation.

### **Mode choice for walk and bicycle**

One of the major differences in modelling NMT modes as compared to motorised modes is the impact of speed on mode choice. Speed of NMT (walk and bicycle) is constant and there is negligible impact of congestion. While other parameters like distance to be travelled, infrastructure quality, safety and security concerns have wider impact over mode choice of walk and bicycle. Along with the mode-related parameters individual socio-economic information needs to be accounted for modelling mode choice for NMT modes of transport.

### **Mode choice for public transport**

Utility of public transport has minimum three inter-related segments i.e. access trip, haul trip and egress trip. Studies have shown that access/egress trip has a significant impact over public transport as a mode choice. The



impact is not only in terms of public transport in vicinity to origin/destination but is also in terms of the discomfort and disutility associated with the modes used for access/egress trips and mode interchanges. The utility function for public transport thus involves waiting time and discomfort of changing modes other than mode related parameters for access/egress trip and haul trip.

### **Trip Assignment**

This step is performed to determine number of trips made by different modes on each of the existing transport network link during peak and off-peak hour period. Trip assignment for NMT should account to land use and density parameters in the vicinity of the infrastructure/facility. Trip assignment for bicycle also includes parameters related to pavement quality, slope, traffic volume and speed. This involves using bicycle compatibility index (BCI) and other such measures.

The person trip OD matrices for current and potential users are converted to vehicle trips based on the average occupancy observed in each mode from the occupancy survey carried out in the city. However, the floating populations coming into the city through the numerous entry points are captured from OD surveys at these locations. These sample surveys are up scaled to total volume based on the traffic volume counts at those locations. **The OD matrices from these surveys are added to the OD from trip distribution to develop the overall OD matrix of the city.**

The mode-wise calibrated OD matrices derived from the above step are assigned on to the road network using User-Equilibrium or Capacity Restraint methods based on Wardrops equilibrium<sup>49</sup> for motorised modes. **For cyclists All or Nothing (AON) method is used in general by considering the minimum BCI or travel distance between ODs of the cyclists as the determining factor for route choice.** Since most links are assumed to have enough capacity for cyclists and since cyclists are sensitive to safety and security issues more than the speed, AON method is adopted.

### **Network Validation**

The link flows observed from trip assignment are compared with the actual traffic flows observed from traffic volume counts conducted at various locations across the city. If it is observed that the link flows from traffic assignment vary from the traffic volume counts, the network needs to be re-checked for its accuracy. Some missing links in the road network are identified through this procedure. However, the larger contributing factor to this error can be the OD matrix derived from trip distribution. The OD matrix has to be re-calibrated for it to match the traffic volume counts. For this, an iterative process is available in modeling softwares called the OD matrix estimation (TransCAD, CUBE)/ t-flow fuzzy (VISUM). Using this procedure, the network is calibrated to match the actual volume counts observed on ground.

For details refer to Demand Assessment Module available at <https://www.dropbox.com/sh/99ngmessm2cgb76/IRv2IC9AwZ>

<sup>49</sup> De Dios Ortuzar, J and L. G. Willumsen (2001). Modelling transport, Wiley.



## Annedure 6. Emission Factors for Vehicle Fleets under Alternative Scenarios

### Emission Factors for Vehicle Fleets under Business as Usual (BAU) Scenario

|                |      | 2011   |        |        | 2020   |        |       | 2030   |        |       |
|----------------|------|--------|--------|--------|--------|--------|-------|--------|--------|-------|
|                |      | Petrol | Diesel | Gas    | Petrol | Diesel | Gas   | Petrol | Diesel | Gas   |
| PM2.5gm/<br>km | CAR  | 0.024  | 0.121  | 0.019  | 0.011  | 0.055  | 0.006 | 0.010  | 0.051  | 0.005 |
|                | MUV  | 0.044  | 0.218  | 0.033  | 0.022  | 0.109  | 0.011 | 0.020  | 0.102  | 0.010 |
|                | 2W   | 0.085  | 0.017  | -      | 0.052  | 0.010  | -     | 0.051  | 0.010  | -     |
|                | 3W   | 0.045  | 0.224  | 0.039  | 0.015  | 0.077  | 0.010 | 0.010  | 0.052  | 0.005 |
|                | TAXI | 0.035  | 0.176  | 0.023  | 0.021  | 0.105  | 0.011 | 0.020  | 0.101  | 0.010 |
|                | BUS  | -      | 0.504  | 0.050  | -      | 0.293  | 0.029 | -      | 0.248  | 0.025 |
|                | HDT  | -      | 0.610  | -      | -      | 0.275  | -     | -      | 0.249  | -     |
|                | LDT  | 0.082  | 0.298  | 0.030  | 0.027  | 0.115  | 0.012 | 0.021  | 0.105  | 0.010 |
|                | TRAC | -      | 0.982  | 0.098  | -      | 0.310  | 0.031 | -      | 0.249  | 0.025 |
| NOx gm/<br>km  | CAR  | 0.147  | 0.734  | 0.107  | 0.104  | 0.522  | 0.054 | 0.102  | 0.510  | 0.051 |
|                | MUV  | 0.215  | 1.076  | 0.153  | 0.162  | 0.811  | 0.084 | 0.159  | 0.797  | 0.080 |
|                | 2W   | 0.112  | 0.558  | 0.082  | 0.061  | 0.306  | 0.031 | 0.061  | 0.303  | 0.030 |
|                | 3W   | 0.184  | 0.921  | 0.159  | 0.079  | 0.394  | 0.048 | 0.062  | 0.308  | 0.031 |
|                | TAXI | 0.205  | 1.027  | 0.141  | 0.159  | 0.794  | 0.080 | 0.158  | 0.791  | 0.079 |
|                | BUS  | -      | 16.788 | 1.679  | -      | 13.287 | 1.329 | -      | 12.454 | 1.245 |
|                | HDT  | -      | 19.391 | 1.939  | -      | 12.984 | 1.298 | -      | 12.542 | 1.254 |
|                | LDT  | 0.342  | 10.977 | 1.098  | 0.144  | 8.746  | 0.875 | 0.126  | 8.860  | 0.886 |
|                | TRAC | -      | 20.025 | 2.002  | -      | 13.297 | 1.330 | -      | 12.558 | 1.256 |
| CO gm/km       | CAR  | 2.838  | 1.641  | 2.838  | 2.341  | 0.705  | 2.341 | 2.347  | 0.654  | 2.347 |
|                | MUV  | 5.854  | 3.119  | 5.854  | 4.359  | 1.088  | 4.359 | 4.294  | 0.972  | 4.294 |
|                | 2W   | 1.462  | 1.462  | 1.462  | 1.021  | 1.021  | 1.021 | 1.011  | 1.011  | 1.011 |
|                | 3W   | 2.616  | 2.616  | 2.616  | 0.743  | 0.743  | 0.743 | 0.516  | 0.516  | 0.516 |
|                | TAXI | 5.230  | 2.352  | 5.230  | 4.301  | 1.004  | 4.301 | 4.261  | 0.964  | 4.261 |
|                | BUS  | -      | 9.802  | 9.802  | -      | 6.471  | 6.471 | -      | 5.631  | 5.631 |
|                | HDT  | -      | 12.701 | 12.701 | -      | 6.175  | 6.175 | -      | 5.656  | 5.656 |
|                | LDT  | 6.012  | 7.070  | 7.070  | 1.313  | 5.054  | 5.054 | 1.053  | 5.108  | 5.108 |
|                | TRAC | -      | 13.187 | 13.187 | -      | 6.449  | 6.449 | -      | 5.673  | 5.673 |



|               |      | 2011   |        |        | 2020   |        |        | 2030   |        |        |
|---------------|------|--------|--------|--------|--------|--------|--------|--------|--------|--------|
|               |      | Petrol | Diesel | Gas    | Petrol | Diesel | Gas    | Petrol | Diesel | Gas    |
| VOC gm/<br>km | CAR  | 0.321  | 0.417  | 0.321  | 0.095  | 0.264  | 0.095  | 0.077  | 0.255  | 0.077  |
|               | MUV  | 0.480  | 0.681  | 0.480  | 0.130  | 0.449  | 0.130  | 0.103  | 0.440  | 0.103  |
|               | 2W   | 0.727  | 0.729  | 0.727  | 0.510  | 0.510  | 0.510  | 0.506  | 0.506  | 0.506  |
|               | 3W   | 1.442  | 1.184  | 1.442  | 0.818  | 0.280  | 0.818  | 0.770  | 0.207  | 0.770  |
|               | TAXI | 0.385  | 0.565  | 0.385  | 0.115  | 0.440  | 0.115  | 0.101  | 0.436  | 0.101  |
|               | BUS  | -      | 2.648  | 2.648  | -      | 2.093  | 2.093  | -      | 1.948  | 1.948  |
|               | HDT  | -      | 3.236  | 3.236  | -      | 2.038  | 2.038  | -      | 1.960  | 1.960  |
|               | LDT  | 3.585  | 1.780  | 1.780  | 1.601  | 1.331  | 1.331  | 1.569  | 1.355  | 1.355  |
|               | TRAC | -      | 3.307  | 3.307  | -      | 2.088  | 2.088  | -      | 1.964  | 1.964  |
| FE km/lit     | CAR  | 14.615 | 16.808 | 14.615 | 17.456 | 20.075 | 17.456 | 17.646 | 20.293 | 17.64  |
|               | MUV  | 12.717 | 14.625 | 12.717 | 14.593 | 16.782 | 14.593 | 14.687 | 16.890 | 14.687 |
|               | 2W   | 61.300 | 70.496 | -      | 73.917 | 85.005 | -      | 74.167 | 85.293 | -      |
|               | 3W   | 19.020 | 21.873 | 19.020 | 23.576 | 27.112 | 23.576 | 24.394 | 28.053 | 24.394 |
|               | TAXI | 12.756 | 14.669 | 12.756 | 14.677 | 16.878 | 14.677 | 14.792 | 17.010 | 14.792 |
|               | BUS  | -      | 3.045  | 3.045  | -      | 3.334  | 3.334  | -      | 3.408  | 3.408  |
|               | HDT  | -      | 2.935  | 2.935  | -      | 3.371  | 3.371  | -      | 3.382  | 3.382  |
|               | LDT  | 5.595  | 5.595  | 5.595  | 5.875  | 5.875  | 5.875  | 5.769  | 5.769  | 5.769  |
|               | TRAC | -      | 2.886  | -      | -      | 3.341  | -      | -      | 3.379  | -      |

### Emission Factors for Vehicle Fleets under Sustainable Urban Transport Scenario

|                 |      | 2011   |        |       | 2020   |        |       | 2030   |        |       |
|-----------------|------|--------|--------|-------|--------|--------|-------|--------|--------|-------|
|                 |      | Petrol | Diesel | Gas   | Petrol | Diesel | Gas   | Petrol | Diesel | Gas   |
| PM2.5 gm/<br>km | CAR  | 0.024  | 0.121  | 0.019 | 0.009  | 0.043  | 0.005 | 0.005  | 0.027  | 0.003 |
|                 | MUV  | 0.044  | 0.218  | 0.033 | 0.017  | 0.086  | 0.009 | 0.011  | 0.055  | 0.005 |
|                 | 2W   | 0.085  | 0.017  | -     | 0.039  | 0.008  | -     | 0.025  | 0.005  | -     |
|                 | 3W   | 0.045  | 0.224  | 0.039 | 0.013  | 0.067  | 0.009 | 0.006  | 0.028  | 0.003 |
|                 | TAXI | 0.035  | 0.176  | 0.023 | 0.016  | 0.081  | 0.008 | 0.010  | 0.051  | 0.005 |
|                 | BUS  | -      | 0.504  | 0.050 | -      | 0.246  | 0.025 | -      | 0.134  | 0.013 |
|                 | HDT  | -      | 0.610  | -     | -      | 0.226  | -     | -      | 0.139  | -     |
|                 | LDT  | 0.082  | 0.298  | 0.030 | 0.023  | 0.094  | 0.009 | 0.012  | 0.061  | 0.006 |
|                 | TRAC | -      | 0.982  | 0.098 | -      | 0.263  | 0.026 | -      | 0.140  | 0.014 |





|               |      | 2011   |        |        | 2020   |         |        | 2030    |         |        |
|---------------|------|--------|--------|--------|--------|---------|--------|---------|---------|--------|
|               |      | Petrol | Diesel | Gas    | Petrol | Diesel  | Gas    | Petrol  | Diesel  | Gas    |
| NOx gm/<br>km | CAR  | 0.147  | 0.734  | 0.107  | 0.081  | 0.404   | 0.043  | 0.054   | 0.270   | 0.027  |
|               | MUV  | 0.215  | 1.076  | 0.153  | 0.126  | 0.628   | 0.066  | 0.085   | 0.425   | 0.043  |
|               | 2W   | 0.112  | 0.558  | 0.082  | 0.046  | 0.228   | 0.023  | 0.030   | 0.151   | 0.015  |
|               | 3W   | 0.184  | 0.921  | 0.159  | 0.067  | 0.334   | 0.042  | 0.034   | 0.168   | 0.017  |
|               | TAXI | 0.205  | 1.027  | 0.141  | 0.121  | 0.604   | 0.061  | 0.080   | 0.398   | 0.040  |
|               | BUS  | -      | 16.788 | 1.679  | -      | 10.951  | 1.095  | -       | 6.737   | 0.674  |
|               | HDT  | -      | 19.391 | 1.939  | -      | 10.523  | 1.052  | -       | 7.010   | 0.701  |
|               | LDT  | 0.342  | 10.977 | 1.098  | 0.118  | 6.927   | 0.693  | 0.073   | 5.116   | 0.512  |
|               | TRAC | -      | 20.025 | 2.002  | -      | 10.898  | 1.090  | -       | 7.055   | 0.706  |
| CO gm/km      | CAR  | 2.838  | 1.641  | 2.838  | 1.797  | 0.554   | 1.797  | 1.240   | 0.346   | 1.240  |
|               | MUV  | 5.854  | 3.119  | 5.854  | 3.378  | 0.866   | 3.378  | 2.291   | 0.519   | 2.291  |
|               | 2W   | 1.462  | 1.462  | 1.462  | 0.763  | 0.763   | 0.763  | 0.504   | 0.504   | 0.504  |
|               | 3W   | 2.616  | 2.616  | 2.616  | 0.641  | 0.641   | 0.641  | 0.283   | 0.283   | 0.283  |
|               | TAXI | 5.230  | 2.352  | 5.230  | 3.277  | 0.772   | 3.277  | 2.143   | 0.485   | 2.143  |
|               | BUS  | -      | 9.802  | 9.802  | -      | 5.419   | 5.419  | -       | 3.056   | 3.056  |
|               | HDT  | -      | 12.701 | 12.701 | -      | 5.066   | 5.066  | -       | 3.164   | 3.164  |
|               | LDT  | 6.012  | 7.070  | 7.070  | 1.099  | 4.006   | 4.006  | 0.613   | 2.949   | 2.949  |
|               | TRAC | -      | 13.187 | 13.187 | -      | 5.369   | 5.369  | -       | 3.195   | 3.195  |
| VOC gm/<br>km | CAR  | 0.321  | 0.417  | 0.321  | 0.077  | 0.205   | 0.077  | 0.041   | 0.135   | 0.041  |
|               | MUV  | 0.480  | 0.681  | 0.480  | 0.107  | 0.348   | 0.107  | 0.055   | 0.235   | 0.055  |
|               | 2W   | 0.727  | 0.729  | 0.727  | 0.382  | 0.382   | 0.382  | 0.252   | 0.252   | 0.252  |
|               | 3W   | 1.442  | 1.184  | 1.442  | 0.666  | 0.239   | 0.666  | 0.421   | 0.114   | 0.421  |
|               | TAXI | 0.385  | 0.565  | 0.385  | 0.091  | 0.335   | 0.091  | 0.051   | 0.219   | 0.051  |
|               | BUS  | -      | 2.648  | 2.648  | -      | 1.728   | 1.728  | -       | 1.055   | 1.055  |
|               | HDT  | -      | 3.236  | 3.236  | -      | 1.654   | 1.654  | -       | 1.096   | 1.096  |
|               | LDT  | 3.585  | 1.780  | 1.780  | 1.280  | 1.053   | 1.053  | 0.908   | 0.782   | 0.782  |
|               | TRAC | -      | 3.307  | 3.307  | -      | 1.713   | 1.713  | -       | 1.104   | 1.104  |
| FE km/lit     | CAR  | 14.615 | 16.808 | 14.615 | 22.139 | 25.460  | 22.139 | 28.842  | 33.168  | 28.842 |
|               | MUV  | 12.717 | 14.625 | 12.717 | 18.446 | 21.213  | 18.446 | 23.917  | 27.504  | 23.917 |
|               | 2W   | 61.300 | 70.496 | -      | 95.119 | 109.387 | -      | 124.297 | 142.942 | -      |
|               | 3W   | 19.020 | 21.873 | 19.020 | 29.130 | 33.500  | 29.130 | 39.395  | 45.304  | 39.395 |
|               | TAXI | 12.756 | 14.669 | 12.756 | 18.698 | 21.503  | 18.698 | 24.699  | 28.404  | 24.699 |
|               | BUS  | -      | 3.045  | 3.045  | -      | 4.075   | 4.075  | -       | 5.531   | 5.531  |
|               | HDT  | -      | 2.935  | 2.935  | -      | 4.144   | 4.144  | -       | 5.382   | 5.382  |
|               | LDT  | 5.595  | 5.595  | 5.595  | 7.273  | 7.273   | 7.273  | 9.075   | 9.075   | 9.075  |
|               | TRAC | -      | 2.886  | -      | -      | 4.095   | -      | -       | 5.373   | -      |



**Note:** Based on national transport emissions analysis outlined in Guttikunda and Mohan (2014); BAU Scenario assumes no change in emission norms as are currently in force. Sustainable Scenario assumes Bharat Stage – IV across India in 2015 and Bharat Stage – V in 2020 for all vehicles. Vehicle population growth based on inputs from SIAM. Electric vehicles have no local emissions however the fuel efficiency numbers (in km/kwh) are as follows for **CAR – 6.67, 2W – 18.75, 3W – 10, TAXI – 6.67, BUS – 0.83**. As there is no fuel economy road maps for them, these numbers are assumed to remain constant for the horizon years.

Guttikunda SK, Mohan D (2014) Re-fueling road transport for better air quality in India. Energy Policy 68:556-561



## Annexure 7. Sample TOR for Appointment of Consultant for Preparation of CMP<sup>50</sup>

### 1. SCOPE OF WORK

The tasks to be carried out are detailed below.

- **Task 1:** Define scope and timeframe of the CMP.
- **Task 2:** Collect data and analyse the existing urban transport environment.
- **Task 3:** Develop Business as Usual (BAU) Scenario.
- **Task 4:** Develop Sustainable Urban Transport Scenarios.
- **Task 5:** Develop Urban Mobility Plans.
- **Task 6:** Prepare Implementation Program.

#### Task 1: Define scope and timeframe of the CMP.

As an initial task, the area covered by the CMP, the planning horizons should be clearly defined and the vision should be set, in association with agencies concerned. The base year should preferably be the current year or the latest year for which data is widely available at the start of work. This will typically be the year preceding the study.

#### Task 2: Collect data and analyse the existing urban transport and environment.

##### Task 2.1 Review City Profile

Prepare a brief profile of the CMP planning area from available documents, including location, land area, regional linkages, demographic data and socio-economic data.

##### Task 2.2 Delineation of Traffic Analysis Zones

CMP aims to ensure safe accessibility for all, irrespective of their socio-economic background and in a way that does not affect the city's environment. TAZs are delineated taking into account various factors like administrative boundaries, physical barriers like water bodies, railway lines which are cutting across zones, road network and public transport network in the study area, homogeneous land uses and special generators like railway station, sports complexes / major freight centres etc maybe considered as separate zones.

##### Task 2.3 Review of Land Use Pattern & Population Density

Once the zones for the study area have been defined, the next step is to collect data in which slums should also be considered as part of residential land use and not a separate land use. Also residential land use should have income groups marked as well.

<sup>50</sup> Note: The TOR should be amended where necessary to reflect each city's characteristics.



CDP or master plans are the prime data sources for reviewing existing land-use patterns. These along with other sources such as information available from the National Urban Information System (NUIS) Scheme, property tax data may be used to compute the residential density and floor space used per activity per unit area. In addition to residential densities, jobs densities must also be studied and analysed.

### Task 2.4 Review of the Existing Transport Systems

A review of the existing transport infrastructure and facilities needs to be done for each transport mode, which may include walking, bicycle, cycle rickshaw, auto rickshaw, shared auto-rickshaw and public transport. The review should include all types of facilities and amenities such as pavement description, intersections treatment, lighting, parking space, parking cost, etc. The following aspects should be reviewed:

- Road Network Inventory (existing infrastructure quality with respect to each of the modes)
- Public Transport System (performance and level of service provision for public transport users)
- Para-Transit System (fleet usage detail, route detail, cost and fare, etc)
- Freight Transport (Vehicle movement and Parking facilities)
- Traffic Conditions on Roads (traffic conditions, manual classified counts and speed & delay surveys)
- Traffic Safety (accident data)

***The data collected and the model developed are to be publicly shared on the Knowledge Management Centre of IUT and with the cities.***

### Task 2.5 Study of Existing Travel Behaviour

Two important considerations should be taken into account while collecting data on travel patterns. The collected data should be representative and cover the travel behaviour of all individuals within a household, and the data should be segregated by social group and trip purpose, which can represent people's perceptions towards different modes of transport in terms of time, cost, comfort, safety and security.

### Task 2.6 Review of Energy and Environment

Quantifying energy consumption for transport is important for estimating the CO<sub>2</sub> and local air pollutant emissions from transport-related activities. To create a complete picture, both top-down and bottom-up approaches for estimating energy consumptions are required.

In general, energy balances cover all fuels, however since the focus here is on transport, only diesel, petrol, LPG, CNG<sup>51</sup> and electricity will be covered. Ambient air quality should be collected for understanding the impacts of transport on air pollution.

---

<sup>51</sup> Where ever applicable



### Task 2.7 Service-Level Benchmarks

Infrastructural data have to be collected other than the data listed in Task 2-4 to Task 2-6. This data should be then compared with the service-level benchmarks to understand the level of service provided to the citizen of certain specified parameters.

### Task 2.8 Analysis and Indicators (Comparison with Benchmarks)

Indicators provide an easy way to communicate a city's transport status, or to make comparisons across alternative scenarios. The indicators for transport level can be broadly divided in the following categories:

- i. Indicators for mobility and accessibility;
- ii. Infrastructure and land use;
- iii. Safety and security;
- iv. Environmental impacts; and
- v. Economic

Most of the indicators can also be directly linked to the Service Level Benchmarks of MoUD.

## Task 3: Development of Business as Usual (BAU) Urban Transport Scenario

### Task 3.1 Framework for Scenarios

The BAU scenario is to be developed based on existing trends without any radical policy interventions for sustainable development and emission mitigation. However, it should consider infrastructure development and land use according to the Master Plans.

### Task 3.2 Socio-Economic Projections

A city's future economic transitions depend on the current economic transitions taking place across the country. As such following projections should be attempted.

- i. Demographic Projections
- ii. Employment Projection
- iii. Industrial Growth Projection

### Task 3.3 Land Use Transitions

The objective of successful land-use development and growth models is to identify where, how much and what kinds of land use will develop. When modelling urban developments, it is necessary to consider changes from vacant to built-up, as well as changes to the land use itself, such as from residential to commercial. Simulation tools should be used to study these types of land use changes. The land use type should be disaggregated into residential, commercial, retail, recreational, industrial, educational, religious, and other categories.



### Task 3.4 Transport Demand Analysis

Demand for passenger transport can be estimated using a four-step model. The model developed can then be used for analyzing the horizon years of the BAU scenario.

### Task 3.5 Technology Transitions

An understanding of vehicles, fuels and CO<sub>2</sub> emissions from electricity used in transportation system is essential to understand the implications of travel demand on CO<sub>2</sub> emissions and air quality.

### Task 3.6 CO<sub>2</sub> Emissions and Air Quality

The framework for sustainable urban mobility needs to utilise the four strategic levers: urban form, Non Motorised Transport (NMT), Public Transport (PT) and Technology. The framework should study the impacts of alternative strategies using key indicators for mobility, safety, and local environment, as well as more aggregate indicators like CO<sub>2</sub> and energy use.

### Task 3.7 Analysis and Indicators (Comparison with Benchmarks)

The indicators for the BAU scenario, similar to those estimated for the base year, should be analysed and compared.

## Task 4: Development of Sustainable Urban Transport Scenarios

### Task 4.1 Framework for Scenario

The sustainable urban transport scenario should visualise social, economic, environmental and technological transitions through which societies respond to climate change, local environment and mobility challenges. The scenario assumes deep emissions cuts using low carbon energy sources (e.g., renewables, natural gas, etc.), highly efficient technologies (e.g., improved vehicle efficiency), adoption of behavioural and consumption styles consistent with sustainable development, changes in urban development and enhanced use of non-motorised and public transport infrastructures.

### Task 4.2 Strategies for Sustainable Urban Transport Scenario

The scenarios described here are related to the plans and policies aimed at limiting private vehicle usage. The scenarios also assume an increase in motorised transport to some extent, which is inevitable given the low level of vehicle use on a per capita basis. Therefore, emphasis is also placed on improving technology in terms of efficiency and emissions. The strategies can be typically categorised into the following four categories:

- Change in urban structure
- Improving non-motorised transport
- Improving public transport
- Technological changes



These strategies will deliver full benefits if they are implemented collectively; however for analysis it may be useful to present them one by one to see the individual effect. The strategies presented here are indicative, and the consultants can adapt them to a city's specific circumstances.

### ***A: Urban Structure***

The scenario should explore alternate development strategies for reducing trip lengths and improving access to public transport through changes in zoning regulations and floor area ratio to achieve higher density, diversity and better design.

### ***B: Non-Motorised Transport Infrastructure***

The scenario should consider improving the use of NMT mode and improvement of NMT infrastructure thereof. The scenario should also consider the safety of NMT users.

### ***C: Public Transport***

Since most Indian cities lack reliable bus service, two kinds of scenarios for public transport should be considered:

1. Improved bus service with compatible pedestrian and bicycle infrastructure
2. Improved bus service and mass transit with compatible pedestrian and bicycle infrastructure

### ***D: Improving Public Transport, NMT and Urban Structure***

This scenario looks at how the implementation of NMT, public transport and urban structure strategies combine and complement each other.

### ***E: Technology***

Technology changes can encompass changes to vehicles design, fuel use, energy use and reduction in CO<sub>2</sub> emissions related to electricity.

### ***F: Regulatory and Financial Measures (Incentives and Disincentives)***

A wide variety of measures can be undertaken to help shift people from private transport modes to sustainable urban transport under a regulatory and financial measure scenario. These measures try to internalise the cost of externalities imposed by private vehicles. These may be incorporated in the model in form of increased generalised cost of travel by private modes.

## **Task 4.3 Transport Demand Analysis of Alternative Strategies for Sustainable Urban Transport**

Based on the above scenario (A, B, C, D and F), improvement in infrastructure for sustainable urban transport needs to be suggested.

## **Task 4.4 Technology Transitions under a Low Carbon Scenario**

In the low carbon scenario, the fuel mix is expected to diversify further from BAU towards bio-fuels, electricity and natural gas. Options for technology transitions should be suggested.



### **Task 4.5 CO<sub>2</sub> Emissions and Air Quality (Refer task 3-6)**

The model framework is same as the BAU scenario for estimating CO2 emissions and air quality.

### **Task 4.6 Analysis and Indicators (Comparison with Benchmarks)**

Sustainable urban transport scenario should be compared with indicators and benchmarks.

## **Task 5: Development of Urban Mobility Plan**

The goal should be to provide for Comfortable Public Transport, NMT incorporated with other modes of transport and Freight movement plan as part of CMP.

The Urban Mobility Plan should be developed in consultation with stakeholders and on the basis of the analysis carried under Tasks 3 and 4. The urban mobility plan can be defined along the following lines; however it is important that the plan includes a phasing plan and implementation agencies:

- i. Integrated Land Use and Urban Mobility Plan
- ii. Public Transport Improvement Plan
- iii. Road Network Development Plan
- iv. NMT Facility Improvement Plan
- v. Freight Movement Plan
- vi. Mobility Management Measures
- vii. Fiscal Measures

### **Task 5.1 Mobility Improvement Measures and NUTP Objectives**

A table should be prepared summarising the relationship between the NUTP objectives and the measures proposed in the CMP, together with a classification of the measures according to their implementation time frame (immediate, short, medium and long term).

## **Task 6: Preparation of the Implementation Program**

Proposed projects should be evaluated and prioritised against clear criteria and classified into immediate, short, medium and long-term. As the CMP is a long-term vision for the city authority, the overall ownership of the CMP lies with ULBs. Given the ULB's dependence on funding, a city's CMP should make a resource assessment for all the projects listed in the CMP and should suggest the city authority, city-specific and project-specific indicative source of financing for the project.

## **2. STUDY DELIVERABLES**

The CMP document should be as per the sample contents attached herewith. The study is to be completed within xx (Refer Table 3). The deliverables are listed below.





| Deliverables                            | Submission date (maximum no. Of months from start of work)* |                                       |                                       |                                       | No. of copies |
|---|---|---------------------------------------|---------------------------------------|---------------------------------------|---------------|
|   | <5 lakh   | 5 – 20 lakh                           | 20 – 40 lakh                          | >40 lakh                              |               |
| Date of signing of agreement            | M   | M                                     | M                                     | M                                     |               |
| Inception Report and Detailed Work Plan | M+1   | M+1                                   | M+1                                   | M+1                                   | X             |
| Interim Report                          | M+3   | M+6                                   | M+9                                   | M+12                                  | X             |
| <b>Draft Final CMP</b>                  | M+7   | M+11                                  | M+17                                  | M+23                                  | X             |
| <b>Final CMP with Executive summary</b> | Within 1 month of receipt of comments                       | Within 1 month of receipt of comments | Within 1 month of receipt of comments | Within 1 month of receipt of comments | X             |

\*The timeline does not include the time taken by the client in approvals and stakeholders consultation

**A soft copy including database material (in PDF and Word /Excel /PPT/Dwg format) shall be submitted with each of the above. Even the model developed should be submitted in PDF as well as in the software used for modelling.**

### 3. COST OF CMP PREPARATION

Tentative cost for CMP preparation as per 2013 price index would be as under which may be increased with the growing price index proportionately.

| City Size             | Rates for New CMP (Rs in Lakh) |
|-----------------------|--------------------------------|
| Less than 0.3 million | 20                             |
| 0.3 - 0.5 million     | 30                             |
| 0.5-1 million         | 40                             |
| 1-2 million           | 60                             |
| 2-4 million           | 80                             |
| 4-8 million           | 120                            |
| Above 8 million       | 200                            |



## 4. PAYMENT SCHEDULE

Payment will be made according to the following Schedule, which is based on the submission of deliverables.

### Submission/Acceptance of Payment as% of total:

| Sl. No. | Component   | Milestone payment |
|---------|---|-------------------|
| 1       | Mobilization Advance                                  | 20%               |
| 2       | Submission of Inception Report and detailed work plan | 20%               |
| 3       | Submission of Interim Report                          | 20%               |
| 4       | Submission of Draft Final Report                      | 20%               |
| 5       | Submission of Final Report and Executive summary      | 20%               |
|         | <b>Total (excluding service tax)</b>                  | <b>100%</b>       |

## 5. INFORMATION ON FIRM AND PROPOSED STAFFING

The consultants will provide details of relevant experience in carrying out similar work along with a copy of certificates/testimonials. CVs for proposed staff should be included with the Technical Proposal.

Staff should have experience in the following disciplines:

- Team Leader/Urban Transport Planner
- Public Transport Expert
- Land Use Expert
- NMT Planning and Traffic Management Specialist
- Highway Engineer
- Traffic Survey and Modelling Specialist

## 6. STAKEHOLDER CONSULTATIONS

The CMP should be discussed with stakeholders at various stages of study throughout the study. An advisory committee and workshops/seminars should be organized to coordinate and develop a consensus. In particular stakeholder workshops/seminars should be held at the following stages:

- Inception Report,
- Interim Report, and
- Draft Final Report stages.

The primary objective should be to develop a working relationship with stakeholders and to obtain their views on the CMP.

## Annexure 8. Sample Work Schedule for Preparation of a CMP for a city

| Task  | Month |   |   |   |   |   |   |   |   |    |    |    |  |
|---|-------|---|---|---|---|---|---|---|---|----|----|----|--|
|   | 1     | 2 | 3 | 4 | 5 | 6 | 7 | 8 | 9 | 10 | 11 | 12 |  |
| Start up meeting (Stakeholders)   |       |   |   |   |   |   |   |   |   |    |    |    |  |
| <b>Introduction</b>   |       |   |   |   |   |   |   |   |   |    |    |    |  |
| Defining Scope  |       |   |   |   |   |   |   |   |   |    |    |    |  |
| <b>Inception Report</b>   |       |   |   |   |   |   |   |   |   |    |    |    |  |
| <b>Data Collection and Analysis of the Existing Urban Transport Environment</b>   |       |   |   |   |   |   |   |   |   |    |    |    |  |
| Data Collection (Primary Surveys and Secondary Data Collection); Surveys for Service Level Benchmarks   |       |   |   |   |   |   |   |   |   |    |    |    |  |
| Review of the City Profile, Land Use Pattern, Population Density, Existing Transport Systems and Delineation of Traffic Analysis Zones  |       |   |   |   |   |   |   |   |   |    |    |    |  |
| Data Collection Approach – Methodology and Sources, Study of Existing Travel behaviour and Review of Energy & Environment   |       |   |   |   |   |   |   |   |   |    |    |    |  |
| Comparison of Existing Urban Transport Environment with Indicators and Benchmarks   |       |   |   |   |   |   |   |   |   |    |    |    |  |
| Submit Draft Report (Data Collection and Analysis of the Existing Urban Transport Environment)  |       |   |   |   |   |   |   |   |   |    |    |    |  |
| <b>Development of Business as Usual (BAU) Scenario based on growth trends and projections</b>   |       |   |   |   |   |   |   |   |   |    |    |    |  |
| Framework for Scenario, Socio-economic Projections and Land use Transitions   |       |   |   |   |   |   |   |   |   |    |    |    |  |
| Transport Demand Analysis, Technology Transitions, CO <sub>2</sub> Emissions & Air Quality, and comparison with the benchmarks  |       |   |   |   |   |   |   |   |   |    |    |    |  |
| Development of Business as Usual (BAU) Scenario   |       |   |   |   |   |   |   |   |   |    |    |    |  |
| <b>Development of Sustainable Urban Transport Scenario by policy interventions</b>  |       |   |   |   |   |   |   |   |   |    |    |    |  |
| Framework for Scenario, Strategies for Sustainable Urban Transport Scenario and Transport Demand Analysis of Alternative Strategies for Sustainable Urban Transport, and Stakeholder consultation |       |   |   |   |   |   |   |   |   |    |    |    |  |
| Change in Technology Transitions under a Low Carbon Scenario, CO <sub>2</sub> Emissions and Air Quality Analysis and comparison with benchmarks   |       |   |   |   |   |   |   |   |   |    |    |    |  |
| Submit Draft Report (Development of Sustainable Urban Transport Scenario)   |       |   |   |   |   |   |   |   |   |    |    |    |  |
| <b>Development of Urban Mobility Plan</b>   |       |   |   |   |   |   |   |   |   |    |    |    |  |
| Urban Mobility Plans  |       |   |   |   |   |   |   |   |   |    |    |    |  |
| <b>Submit Draft CMP Report</b>  |       |   |   |   |   |   |   |   |   |    |    |    |  |
| <b>Preparation of the Implementation Program</b>  |       |   |   |   |   |   |   |   |   |    |    |    |  |
| Programs / Project  |       |   |   |   |   |   |   |   |   |    |    |    |  |
| Stakeholder consultation  |       |   |   |   |   |   |   |   |   |    |    |    |  |
| <b>Final CMP Report</b>   |       |   |   |   |   |   |   |   |   |    |    |    |  |



## Annexure 9. Sample Table of Contents of CMP Document

An example Table of Contents for a CMP document is given below. It is illustrative. Additional Section or other useful information that enhances the objectives may be included.

### Main Report

#### Executive Summary

##### 1. Background

- 1.1. Need for the Study
- 1.2. Methodology

##### 2. City Introduction

- 2.1. Planning area
- 2.2. Land use Distribution
- 2.3. Mobility Indicators
- 2.4. Mobility Needs

##### 3. Challenges

- 3.1. Travel Characteristics
- 3.2. Public Transport
- 3.3. Network
- 3.4. NMT
- 3.5. Traffic Management
- 3.6. Freight
- 3.7. Existing Level of Service (Service Level Benchmarks)

##### 4. Mobility Vision for the City

- 4.1. Vision Statement
- 4.2. Goals
- 4.3. Objective

##### 5. Mobility Improvement Measures

- 5.1. Integrated Land Use and Urban Transport
- 5.2. Public Transport Improvement Plan
- 5.3. Road Network Development Plan
- 5.4. NMT Facility Improvement Plan
- 5.5. Freight Movement plan
- 5.6. Mobility Management Measures
- 5.7. Fiscal Measures
- 5.8. Mobility Improvement Measures and NUTP Objectives

##### 6. Implementation Program

- 6.1. Prioritization of Projects
- 6.2. Identification of Funding Agency
- 6.3. Implementing Agencies



## 7. Outcomes

- 7.1. Improvements in Mobility Indicators
- 7.2. Improvements in SLB

## Annexures

### 1. Planning Forecast

- 1.1. Demographic Forecasting
- 1.2. Landuse in Horizon Year
- 1.3. Economic Forecast

### 2. Base Year Travel Demand Model

- 2.1. Introduction
- 2.2. Transportation Study Process
- 2.3. Study Area Zoning
- 2.4. Network Development
- 2.5. Base Year Travel Pattern
- 2.6. Model Structure

### 3. Development of Business as Usual (BAU) Scenario

- 3.1. Socio Economic Transitions
- 3.2. City Structure Transitions (Landuse)
- 3.3. Travel Demand (Four Step modeling)
- 3.4. Transport Infrastructure
- 3.5. Outcomes of BAU Scenario
- 3.6. Emissions of CO<sub>2</sub> and Local Pollutants

### 4. Alternative Development Scenario (Low Carbon Scenario)

- 4.1. Urban Structure (LandUse Strategy) Strategy
- 4.2. Public Transport Strategy
- 4.3. Mobility & Accessibility Results for PT Scenario
- 4.4. Non-Motorised Transport Strategy
- 4.5. Mobility & Accessibility Results for NMT Scenario
- 4.6. Landuse Intervention, Public Transport Intervention, Non-Motorised Transport Intervention
- 4.7. Mobility & Accessibility Results for Combined Scenario
- 4.8. Comparative Analysis

### 5 Survey Data

### 6 Details of Traffic Demand Modeling

### 7 Details of Stakeholder Consultation

### 8 Self-Appraisal Checklist (enclosed at Annexure 10)

The table of content is for CMPs of cities with more than 0.5 million population and may be modified for smaller cities.



## Annexure 10. Self-Appraisal Checklist to be filled by the consultant/ client

| Sl.        | Item                                  | Details              |                    |
|------------|---------------------------------------|----------------------|--------------------|
|            | Vision/Goal                           |                      |                    |
|            | Study Area                            |                      |                    |
| <b>1.0</b> | <b>Introduction</b>                   |                      |                    |
| <b>1.1</b> | <b>Socio Economic Characteristics</b> |                      |                    |
| 1.11       | Current Population                    |                      |                    |
| 1.12       | Population growth rate (decadal)      |                      |                    |
| 1.13       | Projected population                  |                      |                    |
| 1.14       | Per capita income                     |                      |                    |
| 1.15       | Average Household size                |                      |                    |
| 1.16       | Average household income              |                      |                    |
| 1.17       | Expenditure on transport              |                      |                    |
| 1.18       | Area                                  |                      |                    |
| 1.19       | Population Density                    |                      |                    |
| <b>1.2</b> | <b>Land use (%)</b>                   | <b>Existing Year</b> | <b>Master Plan</b> |
| 1.21       | Residential                           |                      |                    |
| 1.22       | Commercial                            |                      |                    |
| 1.23       | Public & Semi Public                  |                      |                    |
| 1.24       | Recreation                            |                      |                    |
| 1.25       | Industrial                            |                      |                    |
| 1.26       | Transportation                        |                      |                    |
| <b>1.3</b> | <b>Number of registered vehicles</b>  |                      |                    |
| 1.31       | Average annual growth of vehicles     |                      |                    |
| 1.32       | Transportation Modes Registered       |                      |                    |
| a          | Bus (including Mini Bus)              |                      |                    |
| b          | IPT                                   |                      |                    |
| c          | Car                                   |                      |                    |
| d          | Two Wheeler                           |                      |                    |
| e          | NMV                                   |                      |                    |
| f          | Freight (LCV & HCV)                   |                      |                    |
| <b>1.4</b> | <b>Road network Characteristics</b>   |                      |                    |
| a          | Total road length                     |                      |                    |



|            |  |                         |  |                       |  |
|------------|--|-------------------------|--|-----------------------|--|
| b          | Distribution by Right of Way   | <b>Right of Way (m)</b> |  | <b>Percentage (%)</b> |  |
|            |  | <10                     |  |                       |  |
|            |  | 10--20                  |  |                       |  |
|            |  | 20--30                  |  |                       |  |
|            |  | 30--40                  |  |                       |  |
|            |  | 40--60                  |  |                       |  |
|            |  | >60                     |  |                       |  |
|            |  | Total                   |  |                       |  |
| 1.5        | Rail Network   |                         |  |                       |  |
| 1.6        | Airport  |                         |  |                       |  |
| 1.7        | Public Transport Service   |                         |  |                       |  |
| 1.8        | Goods Terminal   |                         |  |                       |  |
| 1.9        | Workforce Participation Rate (WFPR)                                      |                         |  |                       |  |
| <b>2.0</b> | <b>Existing Situation</b>  |                         |  |                       |  |
| <b>2.1</b> | <b>Traffic Zones</b>   |                         |  |                       |  |
| <b>2.2</b> | <b>Zonal Households</b>  |                         |  |                       |  |
| <b>2.3</b> | <b>Surveys Undertaken</b>  |                         |  |                       |  |
| 2.31       | Road Network Inventory   |                         |  |                       |  |
| 2.32       | Speed & Delay Survey in peak and Off peak hour                           |                         |  |                       |  |
| 2.33       | Classified Traffic Volume Counts Surveys                                 |                         |  |                       |  |
| a          | Outer Cordon location  |                         |  |                       |  |
| b          | Mid Block location   |                         |  |                       |  |
| c          | Screen Line location   |                         |  |                       |  |
| d          | Roadside Origin-Destination Survey at cordon points                      |                         |  |                       |  |
| 2.34       | Classified Turning Movement Survey at Intersections                      |                         |  |                       |  |
| 2.35       | Pedestrian Volume Survey   |                         |  |                       |  |
| 2.36       | Parking Survey   |                         |  |                       |  |
| a          | On street Locations  |                         |  |                       |  |
| b          | Off Street Locations   |                         |  |                       |  |
| 2.37       | Commuter Survey at Public Transport Terminals                            |                         |  |                       |  |
| 2.38       | Mass Transport and Intermediate Public Transport (IPT) Passengers Survey |                         |  |                       |  |
| 2.39       | Vehicle Operators' Survey  |                         |  |                       |  |
| 2.40       | Household Survey   |                         |  |                       |  |
| <b>2.4</b> | <b>Survey Results</b>  |                         |  |                       |  |
| 2.41       | Origin-Destination survey  |                         |  |                       |  |
| 2.42       | Intra-city Public Transport Survey                                       |                         |  |                       |  |
| 2.43       | Intercity Bus Passenger Survey   |                         |  |                       |  |
| 2.44       | IPT Surveys  |                         |  |                       |  |



|            |  |  |
|------------|--|--|
| 2.45       | Speed and delay surveys  |  |
| 2.46       | Parking survey   |  |
| 2.47       | Pedestrian Surveys   |  |
| 2.48       | Inventory surveys  |  |
| 2.49       | Mid Block Survey   |  |
| 2.50       | Screen Line Count Survey   |  |
| 2.51       | Intersection Surveys   |  |
| 2.52       | Travel Characteristics   |  |
| a          | Socio Economic Characteristics   |  |
| b          | Travel Characteristics   |  |
| <b>3.0</b> | <b>Urban Transport Benchmarking</b>  |  |
| <b>3.1</b> | <b>Air Quality Status in the city</b>  |  |
| 3.1.1      | SO2 Level  |  |
| 3.1.2      | NO2 Level  |  |
| 3.1.3      | CO Level   |  |
| 3.1.4      | PM 2.5   |  |
| 3.1.5      | PM10   |  |
| <b>3.2</b> | <b>Comprehensive Environmental Pollution Index (CEPI)</b>                    |  |
| <b>3.3</b> | <b>Urban Transport Benchmarking</b>  |  |
| 3.3.1      | Public Transport   |  |
| a          | Presence of Organized Public Transport System in Urban Area                  |  |
| b          | Extent of supply - availability of public transport                          |  |
| c          | service coverage of public transport in the city - bus route network density |  |
| d          | Average Waiting time for intra city public transport users                   |  |
| e          | % fleet as per urban bus specifications operating                            |  |
| 3.3.2      | Travel Speeds along Major Corridors  |  |
| a          | Average Travel speeds of personal vehicles                                   |  |
| b          | Average Travel speeds of public transport                                    |  |
| 3.3.3      | Road Safety  |  |
| a          | Fatalities per lakh population   |  |
| 3.3.4      | Pollution Levels   |  |
| a          | SO2  |  |
| b          | Oxides of Nitrogen   |  |
| c          | CO   |  |
| d          | PM 2.5   |  |
| e          | PM 10  |  |
| 3.3.5      | Overall  |  |





| <b>4.0</b> | <b>Junction Improvement Plans</b>                                 |   |                |             |                |                |             |  |  |  |  |  |  |  |  |  |  |
|------------|---|---|----------------|-------------|----------------|----------------|-------------|--|--|--|--|--|--|--|--|--|--|
| <b>4.1</b> | <b>Junction improvement plans</b>                                 |   |                |             |                |                |             |  |  |  |  |  |  |  |  |  |  |
| <b>4.2</b> | <b>Submissions</b>  |   |                |             |                |                |             |  |  |  |  |  |  |  |  |  |  |
| <b>4.3</b> | <b>Suggested Improvement Measures</b>                             |   |                |             |                |                |             |  |  |  |  |  |  |  |  |  |  |
| 4.3.1      | Geometric Design  |   |                |             |                |                |             |  |  |  |  |  |  |  |  |  |  |
| 4.3.2      | Lane Markings   |   |                |             |                |                |             |  |  |  |  |  |  |  |  |  |  |
| 4.3.3      | Relocation of Bus Stops and Petrol Pumps                          |   |                |             |                |                |             |  |  |  |  |  |  |  |  |  |  |
| 4.3.4      | Junction Signalisation  |   |                |             |                |                |             |  |  |  |  |  |  |  |  |  |  |
| 4.3.5      | Approach to Service Lanes   |   |                |             |                |                |             |  |  |  |  |  |  |  |  |  |  |
| 4.3.6      | Traffic Management Measures                                       |   |                |             |                |                |             |  |  |  |  |  |  |  |  |  |  |
| 4.3.7      | Pedestrian Infrastructure Proposals                               |   |                |             |                |                |             |  |  |  |  |  |  |  |  |  |  |
| 4.3.8      | Alignment Improvement of Approach Roads                           |   |                |             |                |                |             |  |  |  |  |  |  |  |  |  |  |
| 4.3.9      | Area Traffic Plans (ATP)  |   |                |             |                |                |             |  |  |  |  |  |  |  |  |  |  |
| <b>5.0</b> | <b>Base Year Model</b>  |   |                |             |                |                |             |  |  |  |  |  |  |  |  |  |  |
| 5.1        | Land use Forecast   | <table border="1"> <thead> <tr> <th>Sub Area</th> <th>Population</th> <th>Employment</th> </tr> </thead> <tbody> <tr> <td></td> <td></td> <td></td> </tr> <tr> <td></td> <td></td> <td></td> </tr> </tbody> </table>  | Sub Area       | Population  | Employment     |                |             |  |  |  |  |  |  |  |  |  |  |
| Sub Area   | Population  | Employment  |                |             |                |                |             |  |  |  |  |  |  |  |  |  |  |
|            |   |   |                |             |                |                |             |  |  |  |  |  |  |  |  |  |  |
|            |   |   |                |             |                |                |             |  |  |  |  |  |  |  |  |  |  |
| 5.2        | Trip generation model developed (home based work trips mode wise) | <table border="1"> <thead> <tr> <th>Area</th> <th>Equation</th> <th>R<sup>2</sup></th> </tr> </thead> <tbody> <tr> <td></td> <td></td> <td></td> </tr> <tr> <td></td> <td></td> <td></td> </tr> </tbody> </table>   | Area           | Equation    | R <sup>2</sup> |                |             |  |  |  |  |  |  |  |  |  |  |
| Area       | Equation  |   | R <sup>2</sup> |             |                |                |             |  |  |  |  |  |  |  |  |  |  |
|            |   |   |                |             |                |                |             |  |  |  |  |  |  |  |  |  |  |
|            |   |   |                |             |                |                |             |  |  |  |  |  |  |  |  |  |  |
| 5.3        | Trip Attraction model developed(home based work trips mode wise)  |   |                |             |                |                |             |  |  |  |  |  |  |  |  |  |  |
| 5.4        | Trip Distribution by using Gravity model                          | <p>Doubly constraint gravity model: <math>T_{ijm} = r_i G_i S_j A_j F_{ijm}</math> Calibrated Mode choice parameters</p> <table border="1"> <thead> <tr> <th>Mode</th> <th>K</th> <th><math>\alpha</math></th> <th><math>\beta</math></th> </tr> </thead> <tbody> <tr> <td></td> <td></td> <td></td> <td></td> </tr> <tr> <td></td> <td></td> <td></td> <td></td> </tr> </tbody> </table> | Mode           | K           | $\alpha$       | $\beta$        |             |  |  |  |  |  |  |  |  |  |  |
| Mode       | K   | $\alpha$  | $\beta$        |             |                |                |             |  |  |  |  |  |  |  |  |  |  |
|            |   |   |                |             |                |                |             |  |  |  |  |  |  |  |  |  |  |
|            |   |   |                |             |                |                |             |  |  |  |  |  |  |  |  |  |  |
| 5.5        | Modal Split   | <table border="1"> <thead> <tr> <th>Mode</th> <th>Trip</th> <th>% Share</th> <th>External Trips</th> <th>Total Trips</th> </tr> </thead> <tbody> <tr> <td></td> <td></td> <td></td> <td></td> <td></td> </tr> <tr> <td></td> <td></td> <td></td> <td></td> <td></td> </tr> </tbody> </table>  | Mode           | Trip        | % Share        | External Trips | Total Trips |  |  |  |  |  |  |  |  |  |  |
| Mode       | Trip  | % Share   | External Trips | Total Trips |                |                |             |  |  |  |  |  |  |  |  |  |  |
|            |   |   |                |             |                |                |             |  |  |  |  |  |  |  |  |  |  |
|            |   |   |                |             |                |                |             |  |  |  |  |  |  |  |  |  |  |
| 5.6        | Trip Assignment (link v/c condition)                              | <table border="1"> <thead> <tr> <th>S. No.</th> <th>Road</th> <th>V/C Ratio</th> <th>Avg</th> </tr> </thead> <tbody> <tr> <td></td> <td></td> <td></td> <td></td> </tr> <tr> <td></td> <td></td> <td></td> <td></td> </tr> </tbody> </table>  | S. No.         | Road        | V/C Ratio      | Avg            |             |  |  |  |  |  |  |  |  |  |  |
| S. No.     | Road  | V/C Ratio   | Avg            |             |                |                |             |  |  |  |  |  |  |  |  |  |  |
|            |   |   |                |             |                |                |             |  |  |  |  |  |  |  |  |  |  |
|            |   |   |                |             |                |                |             |  |  |  |  |  |  |  |  |  |  |
| 5.7        | Model Validation  |   |                |             |                |                |             |  |  |  |  |  |  |  |  |  |  |
| <b>6.0</b> | <b>Strategies for Transport Development</b>                       |   |                |             |                |                |             |  |  |  |  |  |  |  |  |  |  |
| <b>6.1</b> | <b>Development Scenarios</b>                                      |   |                |             |                |                |             |  |  |  |  |  |  |  |  |  |  |
| 6.1.1      | Scenarios developed   |   |                |             |                |                |             |  |  |  |  |  |  |  |  |  |  |



|            |   |  |
|------------|---|--|
| 6.1.2      | Selected Scenario   |  |
| 6.1.3      | Considerations under CMP Scenario                                 |  |
| <b>6.2</b> | <b>Transport Scenarios</b>  |  |
| 6.2.1      | Demand Forecast   |  |
| 6.2.2      | Scenario Evaluation Criteria                                      |  |
| 6.2.3      | Scenarios developed   |  |
| 6.2.4      | Scenario selected on the basis of pre defined evaluation criteria |  |
| 6.2.5      | Highlights of CMP Scenario  |  |
| <b>7.0</b> | <b>Mobility Management Measures</b>                               |  |
| <b>7.1</b> | <b>Core Area Improvement</b>                                      |  |
| <b>7.2</b> | <b>Traffic Control and Road Safety</b>                            |  |
| <b>8.0</b> | <b>Transport System Plan: 2031</b>                                |  |
| <b>8.1</b> | <b>Focus</b>  |  |
| <b>8.2</b> | <b>Road Network Development Plan</b>                              |  |
| 8.2.1      | Mobility Corridors  |  |
| 8.2.2      | Road Widening   |  |
| 8.2.3      | Missing Links   |  |
| 8.2.4      | Railway Over/Under Bridges at Level Crossings                     |  |
| 8.2.5      | Flyover Proposals   |  |
| <b>8.3</b> | <b>Public Transport Plan</b>                                      |  |
| 8.3.1      | Focus   |  |
| 8.3.2      | Proposed Mass Rapid Transit Corridors                             |  |
| a          | Mass Rapid Transit  |  |
| b          | Bus System Improvement Plan                                       |  |
| c          | Typical Cross-sectional details of Right of Way                   |  |
| 8.3.3      | Bus Infrastructure Requirement                                    |  |
| 8.3.4      | Intra-city Interchanges   |  |
| 8.3.5      | Para Transit Improvement Plan                                     |  |
| 8.3.6      | Other Measures  |  |
| <b>8.4</b> | <b>NMT Improvement Plan</b>                                       |  |
| 8.4.1      | Recommended Measures  |  |
| 8.4.2      | Grade Separated Pedestrian Facilities (GSPF)                      |  |
| <b>8.5</b> | <b>Regional Traffic</b>   |  |
| 8.5.1      | Inter State Bus Terminals (ISBT)                                  |  |
| 8.5.2      | Passenger Rail Terminals  |  |
| 8.5.3      | Freight Terminals   |  |
| <b>8.6</b> | <b>Parking</b>  |  |
| <b>8.7</b> | <b>Integration of Land use and Transport Planning</b>             |  |
| <b>9.0</b> | <b>Regulatory and Institutional Measures</b>                      |  |
| <b>9.1</b> | <b>Regulatory Measures</b>  |  |



|             |   |  |
|-------------|---|--|
| <b>9.2</b>  | <b>Institutional Measures</b>                                   |  |
| 10.0        | Fiscal Measures   |  |
| 10.1        | Fare Policy for Public Transport                                |  |
| 10.2        | Automatic Fare Revision   |  |
| 10.3        | Parking Pricing Strategy  |  |
| <b>11.0</b> | <b><i>Mobility Improvement Measures and NUTP Objectives</i></b> |  |
| <b>12.0</b> | <b><i>Service Level Benchmarking</i></b>                        |  |
| <b>13.0</b> | <b><i>Stake Holder Consultations</i></b>                        |  |
| 13.1        | Stakeholders consulted for preparing CMP                        |  |
| 13.2        | Major Inputs  |  |
| <b>14.0</b> | <b><i>Investment and Implementation Program (Phasewise)</i></b> |  |
| 14.1        | Public Transport Projects                                       |  |
| 14.2        | Road Infrastructure Improvement Projects                        |  |
| 14.3        | Parking   |  |
| 14.4        | Junction Improvement (29 Junctions)                             |  |
| 14.5        | Freight Terminals   |  |
| 14.6        | Total Investment Requirements                                   |  |
| 14.7        | Funding Plan  |  |
| 14.8        | Agenda for Action   |  |
| <b>15.0</b> | <b><i>Projects other than JNNURM:</i></b>                       |  |
|             | NOTES:  |  |



## Annexure 11. Indicative Checklist for Evaluating CMPs

This Annexure provides a tentative checklist of the main points to be presented in a CMP. It is designed to assist with the CMP evaluation process.

|   | Yes | Partial | None |
|---|-----|---------|------|
| <b>Evaluation of CMP Vision</b>   |     |         |      |
| Is the vision in line with sustainable transport system definition?   |     |         |      |
| Is the key focus area of NUTP i.e. planning for people taken care of?   |     |         |      |
| Is it consistent with vision of CDP / Master Plan? If not, gap area identified?   |     |         |      |
| Is a stakeholder and citizen involvement considered while preparing vision for CMP? Involvement/consultation should be throughout the study.            |     |         |      |
| <b>Evaluation of CMP content</b>  |     |         |      |
| Sustainability indicator – Access and equity e.g. equitable allocation of road space, connectivity of slum/urban poor residential areas attended?       |     |         |      |
| Are the special recommendations for mobility of the physically challenged, women, children and elderly made?  |     |         |      |
| Are the integrated land use and transport development along with promoting balanced regional growth, in line with regional development strategies made? |     |         |      |
| Is mass transportation promoted?  |     |         |      |
| Is NMT promoted?  |     |         |      |
| Are effective traffic demand management principles and systems proposed?  |     |         |      |
| Is the use of clean alternative fuels like electricity from clean/renewable sources in public, private and IPT vehicles promoted?                       |     |         |      |
| Is efficient movement of freight traffic planned/promoted?  |     |         |      |
| <b>Scope of CMP</b>   |     |         |      |
| Are the target areas and planning horizons clearly identified?  |     |         |      |
| <b>Existing Land Use Plan</b>   |     |         |      |
| Does the CMP fully review the existing land use plans?  |     |         |      |
| Have land use issues in relation to mobility improvement been identified?   |     |         |      |
| <b>Existing Transport System</b>  |     |         |      |
| Does the CMP review the existing reports, plans and proposals?  |     |         |      |
| Does the CMP review and summarize the existing transport infrastructure?  |     |         |      |
| Does the CMP review and summarize the existing public transport system?   |     |         |      |
| Does the CMP review environmental and social conditions?  |     |         |      |
| <b>Existing Transport Demand</b>  |     |         |      |
| Have the necessary data for existing transport demand been collected, based on the specified formats?   |     |         |      |
| Has the base-year transport demand model been developed with the proper methodology?  |     |         |      |



|   | Yes | Partial | None |
|---|-----|---------|------|
| Does the base-year transport demand model estimate traffic volumes with a high correlation to observed traffic volumes?                 |     |         |      |
| Analysis of the Existing Traffic/Transport Environment  |     |         |      |
| Does the CMP show adequately traffic characteristics?   |     |         |      |
| Has an analysis of the road network been carried out, based on the results of a base-year transport demand model?                       |     |         |      |
| Have specific issues for the city been identified, based on comparative analyses with data from other cities?                           |     |         |      |
| Have issues with the existing traffic/transport environment been addressed, with reference to compiled information and data?            |     |         |      |
| Land Use Scenarios  |     |         |      |
| For cities with a Master Plan: Has the land use scenarios assumed in the CMP reflected the growth pattern indicated in the Master Plan? |     |         |      |
| For cities without a Master Plan: Have realistic and feasible land use scenarios been developed, considering the existing situation?    |     |         |      |
| Transport Network Scenarios   |     |         |      |
| Have realistic and feasible transport network scenarios been developed?   |     |         |      |
| Evaluation of Strategic Land Use and Transport Patterns   |     |         |      |
| Is there appropriate consistency between the model and future transport network/land use scenarios?                                     |     |         |      |
| Has each scenario been evaluated and compared with the indicators listed in the toolkit?  |     |         |      |
| Has the network evaluation been conducted with scenarios based on the proposed measures?  |     |         |      |
| Mobility Framework  |     |         |      |
| Does the mobility framework properly describe the future mobility strategy?   |     |         |      |
| Does the mobility framework focus on integration of transport development and land use planning?  |     |         |      |
| Have the mobility framework and associated proposed measures been revised, based on the results of the network evaluation?              |     |         |      |
| Does the mobility framework include consideration of non-motorised transport (NMT), including pedestrian traffic?                       |     |         |      |
| Mobility Improvement Measures   |     |         |      |
| Are the proposed urban transport measures based on the mobility framework?  |     |         |      |
| Have sufficient public transport measures been included?  |     |         |      |
| Have sufficient traffic management measures been included?  |     |         |      |
| Social and Environmental Considerations   |     |         |      |
| Have the social and environmental consideration been addressed appropriately?   |     |         |      |



## Annexure 12. List of Maps to be Prepared

1. Maps of Road Network Inventory including:
  - a. Location of existing footpaths
  - b. Major intersection locations
  - c. Existing cycle tracks and widths
  - d. Location of existing dedicated bus lanes
  - e. Existing bus stops – with and without shelters
  - f. Existing bus terminals and depots
  - g. Existing para-transit stops
  - h. ROW of all major streets
  - i. Location of on-street/off-street parking
  - j. Location of regulated parking
2. Maps of Public Transport Systems:
  - a. Key bus routes
  - b. Key para-transit routes
  - c. Frequency counts during peak hours along transit routes (including bus and para-transit)
  - d. Occupancy counts during peak hours along transit routes (including bus and para-transit)
3. Road safety maps:
  - a. Key crash locations/black spots

## Annexure 13. Example of cross-classification method

| Population Density (Persons/hectare) | Distance from Centre of Town | HH Members/Earner | Mean Trip Length | PT choice | Bicycle Choice | Two Wheel Choice | Walk Choice | Population Density (Persons/hectare) | Distance from Centre of Town | HH Members/Earner | Mean Trip Length  | PT choice | Bicycle Choice | Two Wheel Choice | Walk Choice |  |  |
|--------------------------------------|------------------------------|-------------------|------------------|-----------|----------------|------------------|-------------|--------------------------------------|------------------------------|-------------------|-------------------|-----------|----------------|------------------|-------------|--|--|
| < 150                                | < 2.5                        | < 1               |                  |           |                |                  |             | 250 - 500                            | < 2.5                        | < 1               |                   |           |                |                  |             |  |  |
|                                      |                              | 1 - 1.5           |                  |           |                |                  |             |                                      |                              | 1 - 1.5           | Travel Behavior C |           |                |                  |             |  |  |
|                                      |                              | 1.5 - 3           |                  |           |                |                  |             |                                      |                              | 1.5 - 3           |                   |           |                |                  |             |  |  |
|                                      |                              |                   | > 3              |           |                |                  |             |                                      |                              |                   | > 3               |           |                |                  |             |  |  |
|                                      | 2.5 - 5                      | < 1               |                  |           |                |                  |             |                                      |                              | 2.5 - 5           | < 1               |           |                |                  |             |  |  |
|                                      |                              | 1 - 1.5           |                  |           |                |                  |             |                                      |                              |                   | 1 - 1.5           |           |                |                  |             |  |  |
|                                      |                              | 1.5 - 3           |                  |           |                |                  |             |                                      |                              |                   | 1.5 - 3           |           |                |                  |             |  |  |
|                                      |                              |                   | > 3              |           |                |                  |             |                                      |                              |                   | > 3               |           |                |                  |             |  |  |
|                                      | 5 - 7.5                      | < 1               |                  |           |                |                  |             |                                      |                              | 5 - 7.5           | < 1               |           |                |                  |             |  |  |
|                                      |                              | 1 - 1.5           |                  |           |                |                  |             |                                      |                              |                   | 1 - 1.5           |           |                |                  |             |  |  |
|                                      |                              | 1.5 - 3           |                  |           |                |                  |             |                                      |                              |                   | 1.5 - 3           |           |                |                  |             |  |  |
|                                      |                              |                   | > 3              |           |                |                  |             |                                      |                              |                   | > 3               |           |                |                  |             |  |  |
| > 7.5                                | < 1                          |                   |                  |           |                |                  |             | > 7.5                                | < 1                          |                   |                   |           |                |                  |             |  |  |
|                                      | 1 - 1.5                      |                   |                  |           |                |                  |             |                                      | 1 - 1.5                      | Travel Behavior B |                   |           |                |                  |             |  |  |
|                                      | 1.5 - 3                      |                   |                  |           |                |                  |             |                                      | 1.5 - 3                      |                   |                   |           |                |                  |             |  |  |
|                                      |                              | > 3               |                  |           |                |                  |             |                                      | > 3                          |                   |                   |           |                |                  |             |  |  |
| 150 - 250                            | < 2.5                        | < 1               |                  |           |                |                  |             | > 500                                | < 2.5                        | < 1               |                   |           |                |                  |             |  |  |
|                                      |                              | 1 - 1.5           |                  |           |                |                  |             |                                      |                              | 1 - 1.5           |                   |           |                |                  |             |  |  |
|                                      |                              | 1.5 - 3           |                  |           |                |                  |             |                                      |                              | 1.5 - 3           |                   |           |                |                  |             |  |  |
|                                      |                              |                   | > 3              |           |                |                  |             |                                      |                              | > 3               |                   |           |                |                  |             |  |  |
|                                      | 2.5 - 5                      | < 1               |                  |           |                |                  |             |                                      |                              | 2.5 - 5           | < 1               |           |                |                  |             |  |  |
|                                      |                              | 1 - 1.5           |                  |           |                |                  |             |                                      |                              |                   | 1 - 1.5           |           |                |                  |             |  |  |
|                                      |                              | 1.5 - 3           |                  |           |                |                  |             |                                      |                              |                   | 1.5 - 3           |           |                |                  |             |  |  |
|                                      |                              |                   | > 3              |           |                |                  |             |                                      |                              |                   | > 3               |           |                |                  |             |  |  |
|                                      | 5 - 7.5                      | < 1               |                  |           |                |                  |             |                                      |                              | 5 - 7.5           | < 1               |           |                |                  |             |  |  |
|                                      |                              | 1 - 1.5           |                  |           |                |                  |             |                                      |                              |                   | 1 - 1.5           |           |                |                  |             |  |  |
|                                      |                              | 1.5 - 3           |                  |           |                |                  |             |                                      |                              |                   | 1.5 - 3           |           |                |                  |             |  |  |
|                                      |                              |                   | > 3              |           |                |                  |             |                                      |                              |                   | > 3               |           |                |                  |             |  |  |
| > 7.5                                | < 1                          |                   |                  |           |                |                  |             | > 7.5                                | < 1                          |                   |                   |           |                |                  |             |  |  |
|                                      | 1 - 1.5                      |                   |                  |           |                |                  |             |                                      | 1 - 1.5                      |                   |                   |           |                |                  |             |  |  |
|                                      | 1.5 - 3                      | Travel Behavior A |                  |           |                |                  |             |                                      | 1.5 - 3                      |                   |                   |           |                |                  |             |  |  |
|                                      |                              | > 3               |                  |           |                |                  |             |                                      | > 3                          |                   |                   |           |                |                  |             |  |  |

**Option 1:** The socio-demographic forecast indicates that in the future year, the number of household members per earner will reduce, that is there are more earners in each family. The decision maker can then take the decision to increase the density in one of the peripheral areas of the city. This will mean that the forecast of the travel behaviour A (as shown in figure above) for the same area will be reflected as travel behaviour B (as shown in figure above) for the future year.

**Option 2:** The decision maker in this case adopts all strategies of option 1, but also plans to convert a mono-centric town to a poly-centric town ensuring the distance from anywhere in the town to a sub-centre in the town is not more than 2.5 kilometer. In this case the forecasted travel behaviour will be C.

Likewise the decision makers can look at several options that will help them achieve their sustainable transport objective, and implement the best-suited objective. In the above example only three indicators are used (Population density, distance from city centre, HH members per earner in the household). However, a different set of indicators or more can be used to generate a similar cross-classification table for better decision making. For example for a PT-related decision, the indicator distance from /to PT stop can be included as the fourth indicator in this cross-classification table. For walk and bicycle choice, road safety related indicator could have been included in this cross-classification table.





