



REGIONAL SEAS

Guidelines for Integrated Management of Coastal and Marine Areas



UNEP Regional Seas Reports and Studies No. 161

Prepared in cooperation with  PRIORITY
ACTION
PROGRAMME

UNEP 1995

Note: This document was prepared by the Priority Actions Programme Regional Activity Centre (PAP/RAC) of the Mediterranean Action Plan - UNEP, under the guidance of the Oceans and Coastal Areas Programme Activity Centre (OCA/PAC) of UNEP. The financial support for the preparation and review of the document was provided by OCA/PAC through Project FP/5101-90-03-2228.

The designations employed and the presentation of the material in this document do not imply the expression of any opinion whatsoever on the part of UNEP concerning the legal status of any State, Territory, city or area, or its authorities, or concerning the delimitation of its frontiers or boundaries. The document contains the views expressed by the authors acting in their individual capacities and do not necessarily represent the views of UNEP.

© 1995 United Nations Environment Programme
P. O. Box 30552, Nairobi, Kenya

ISBN 92-807-1487-2

This publication may be reproduced in whole or in part and in any form for educational and non-profit purposes without special permission from the copyright holder, provided acknowledgement of the source is made. UNEP would appreciate receiving a copy of any publication that uses this material as a source.

No use of this publication may be made for resale or for any other commercial purposes whatsoever without prior permission in writing from UNEP.

For bibliographic purposes this document may be cited as:

UNEP: Guidelines for Integrated Management of Coastal and Marine Areas - With Special Reference to the Mediterranean Basin. UNEP Regional Seas Reports and Studies No. 161. Split, Croatia, PAP/RAC (MAP-UNEP), 1995.



REGIONAL SEAS

Guidelines for Integrated Management of Coastal and Marine Areas

With Special Reference to the
Mediterranean Basin

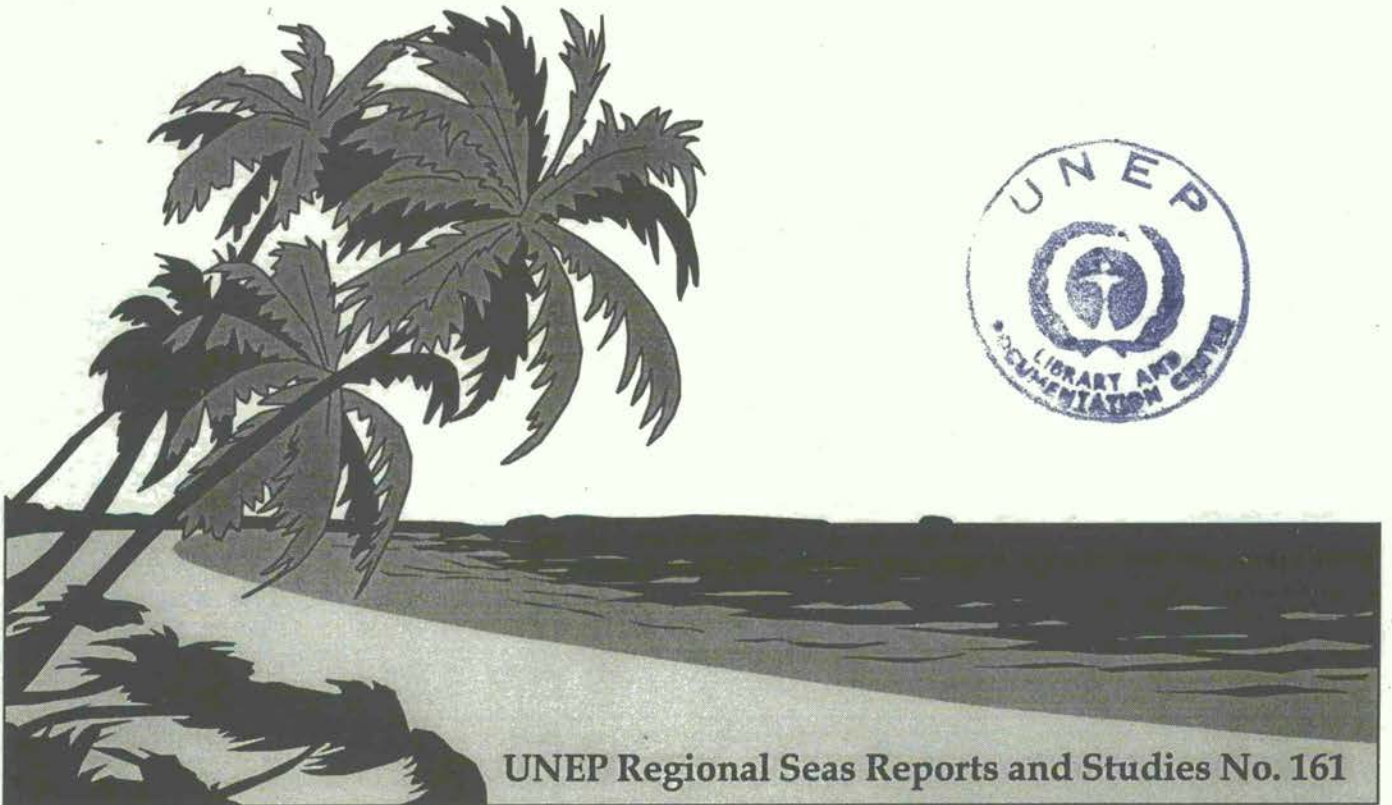

UNEP Regional Seas Reports and Studies No. 161

Prepared in cooperation with  PRIORITY
ACTIONS
PROGRAMME

UNEP 1995

PREFACE

Chapter 17 of Agenda 21 (United Nations Conference on Environment and Development held in Rio de Janeiro from 3 to 14 June 1992) on *Protection of the Oceans, all kinds of Seas, including Enclosed and Semi-enclosed Seas, and Coastal Areas and the Protection, Rational Use and Development of their Living Resources*, concluded that: "The marine environment - including the oceans and all seas and adjacent coastal areas - forms an integrated whole that is an essential component of the global life-support system and a positive asset that presents opportunities for sustainable development". The Conference further concluded that as the coastal area contains diverse and productive habitats and ecosystems important for human settlement, development and local subsistence, and noting that more than half the world's population lives within 60 km of the shoreline, and is estimated to rise to three quarters by the year 2020, recommended that new integrated approaches to marine and coastal area management and development, at the national, sub-regional, regional and global levels be developed.

It is now widely accepted that sectoral activities produce combined environmental impacts resulting in marine and fresh water pollution, air pollution, loss of marine resources, loss of natural land resources, land degradation and destruction of historic sites, and that policies to reduce coastal degradation have been based on the sectoral approach and have therefore failed, usually transferring problems among the resources and products which coastal and marine areas produce, as well as to the services they support, unable to take into account the overall impact of coastal development on resources.

Sectoral approaches to the management and planning of natural resources utilisation can no longer meet the requirements of the management of complex systems such as coastal areas. It is within this frame that UNCED "Agenda 21", called for the promotion of adaptable and flexible process of integrated coastal and marine areas management (ICAM).

OCA/PAC, through its Regional Seas Programme which includes thirteen regions world-wide with well over 140 coastal States and Territories participating, supports and coordinates, on an international, regional, subregional, national and local level, the rational management of the marine environment as a whole, and the coastal areas specifically. It is towards this end that the preparation of the Guidelines was commissioned.

The Mediterranean Action Plan was the first regional seas programme of UNEP to be established within the framework of the Convention for the Protection of the Mediterranean Sea against Pollution (Barcelona Convention). Over the last 20 years, the Mediterranean Action Plan (MAP), has provided the organisational structure for the implementation of activities aimed at the protection of the sea, and at sustainable development of the Mediterranean coastal areas. The Priority Action Programme (PAP) as one of the regional centres of MAP, is entrusted with the implementation of priority actions, the integrated management of coastal areas being the most important. The centre has accumulated many years of experience and knowledge not only on the problems of the Mediterranean coastal areas, but of other regions of the world as well.

This wealth of experience was subsequently documented in these Guidelines. Written by Valerie Brachya, Ferenz Juhasz, Arsen Pavasovic and Ivica Trumbic, this document represents a practical realization of the tasks set out by Agenda 21 which states that States should cooperate in the preparation of national guidelines for ICAM, drawing on existing experience (Chapter 17.11).

The first draft of these Guidelines was reviewed on the basis of the comments given by Ms. Astrálaga (OCA/PAC), Messrs. D. Insull (FAO), S. Keckes, Consultant to PAP, and L. Jetic, Deputy Coordinator of the Coordinating Unit for the Mediterranean Action Plan. The first revision of the document was made during an expert meeting convened in Geneva in February 1993, while the second revision was completed during an interregional meeting held in Rome in December 1993. The Guidelines were finalized at a meeting held in the offices of OCA/PAC in Nairobi in February 1994.

Neither ICAM nor these Guidelines are a panacea for all problems of coastal areas, nor are they a universal tool applicable in the same way in all the regional seas. However, there are elements that are universal, such as the gradual process of ICAM implementation. Other elements such as: the importance of individual natural resources, possibilities of implementation, institutional arrangements, or the application of tools and techniques, must be understood and applied with flexibility. The applicability of the Guidelines must be evaluated and possible amendments suggested to adapt them to other situations, if applied in areas outside the Mediterranean.

At present the Guidelines are being applied in the Eastern and West and Central African Regional Seas Programmes. The Guidelines will be amended based on experiences gained in its application in the regions, and the revision published.

It is hoped that these Guidelines will be used as a tool by a large audience for the implementation of ICAM. We shall be grateful for any comments, amendments, and proposals for the improvement of the Guidelines, especially if resulting from the experience in their practical application.

A special expression of appreciation is due Mr. P. Schröder, Director, OCA/PAC, for his help in reviewing the earlier drafts, Mr. P. Akiwumi, Programme Officer and Ms. Ruth Batten, Editorial Assistant, OCA/PAC, for editing and finalizing the document for printing, and Mr. W. Clarke for his professional suggestions on the improvement of the language of the draft text.

CONTENTS

PREFACE	i
LIST OF BOXES, TABLES AND FIGURES	iv
EXECUTIVE SUMMARY	vi
1. INTRODUCTION	1
2. JUSTIFICATION FOR INTEGRATED COASTAL AREA MANAGEMENT	2
2.1 Common problems and conflicts in coastal areas	2
2.1.1 Introduction	2
2.1.2 Land and marine uses: their impacts on coastal areas	3
2.1.3 How economic activities affect coastal resources.....	7
2.1.4 Summary of interactions between coastal uses, activities and resources.....	11
2.1.5 Climate change	13
2.1.6 Risks and hazards	13
2.2 The need for and the concept of ICAM	15
2.2.1 The need for ICAM	15
2.2.2 The principles and concept of ICAM	16
2.2.3 Guidelines for sectoral policies in the context of ICAM	18
3. THE DEVELOPMENT AND IMPLEMENTATION OF ICAM	19
3.1 Approaches to ICAM	19
3.2 Stages of the ICAM process	20
3.2.1 Initiation of the ICAM process	23
3.2.2 Preparatory phase of the planning stage	25
3.2.3 Analysis and forecasting.....	27
3.2.4 Definition of goals and strategies	28
3.2.5 Integration of detailed plans	30
3.2.6 Implementation of plans	32
3.2.7 Monitoring and evaluation.....	33
3.3 Institutional, legal and financial arrangements for ICAM	33
3.3.1 Institutional arrangements	33
3.3.2 Legal arrangements.....	35
3.3.3 Financing mechanism	36
4. TOOLS AND TECHNIQUES FOR ICAM	37
4.1 Data management	37
4.2 Evaluation and Assessment Techniques	40
4.2.1 Environmental assessment.....	40
4.2.2 Risk assessment and management	43
4.2.3 Economic evaluation techniques	44
4.2.3.1 Cost/benefit analysis.....	45
4.2.3.2 Least-cost analysis.....	46
4.2.4 Prospective studies: development-environment scenarios.....	46
4.3 Instruments for implementation	47
4.3.1 Regulatory instruments.....	47
4.3.2 Economic instruments	48
4.3.3 Bargaining and negotiation.....	49
4.3.4 Conflict resolution or techniques for consensus building and integration.....	49
ANNEX I: Some basic definitions relative to ICAM	51
ANNEX II: Mediterranean coastal resources and their problems	56
ANNEX III: Data base management	61
ANNEX IV: Integrated planning study for the island of Rhodes	63
ANNEX V: Israeli national outline scheme for the Mediterranean coast	68
ANNEX VI: Objectives and thematic framework for the mitigation of seismic risk	70
ANNEX VII: Economic instruments	72
BIBLIOGRAPHY	76

LIST OF BOXES

Box 1 Urban Population in Mediterranean Coastal Areas	4
Box 2 Population Variations in the Mediterranean Coast of France(1988)	4
Box 3 Mediterranean Fisheries: Present Situation	5
Box 4 Estimated Annual Incidence of Oil Pollution in the Mediterranean	6
Box 5 The Island of Rhodes: Estimate of Impact of Coastal Activities on the Environment - Main Problem Areas	8
Box 6 Loss of Wetlands in the Mediterranean.....	9
Box 7 The Urgency for and Benefits of ICAM	15
Box 8 Some Principles for ICAM.....	16
Box 9 Objectives of Integrated Coastal Area Management.....	17
Box 10 "Top-down" and "bottom-up" Approaches to ICAM.....	19
Box 11 Integrated Coastal Area Management Programme for the Syrian Coastal Area	23
Box 12 The Coordination Mechanism for ICAM.....	24
Box 13 Contents of the "Integrated Planning Study for the Island of Rhodes, Greece".....	26
Box 14 Coastal Management Strategies	30
Box 15 Some of the Major Dimensions to be Taken into Consideration in ICMP.....	31
Box 16 Possible Framework for ICAM of Izmir Bay (Turkey).....	35
Box 17 A Suggested Database for ICAM.....	38
Box 18 Carrying Capacity Assessment Study for the Island of Rhodes.....	42
Box 19 Discounted Benefits of Restoration of Izmir Bay (1990-2025)	45
Box 20 Regulatory Instruments: Standards.....	48

LIST OF TABLES

Table 1 Matrix of Possible Interactions between Economic Activities and Effects on Coastal Resources	12
Table 2 Stages, Phases, Activities and Outputs of the ICAM Process	21

LIST OF FIGURES

Figure 1 Flowchart for ICAM Process	22
Figure 2 An Example of Application of GIS in the ICAM Process	39
Figure 3 Simplified Flow Chart for the EIA Procedure.....	41
Figure 4 Risk Matrix.....	44
Figure 5 Parts of the Coastal Area.....	52
Figure 6 The island of Rhodes.....	67
Figure 7 The island of Rhodes - land cover map.....	67

EXECUTIVE SUMMARY

Population pressure, particularly the growth of urban areas, combined with the rapid expansion of industry and tourism in coastal areas and extensive exploitation of marine resources has created a worldwide concern about sustainable development of these areas and their natural and environmental resources. The harmful impacts of these human activities are visible all over the world and are well documented in the Mediterranean basin. This document is largely based on resource and environmental conflicts and their resolution in that region.

Coastal resources are used and exploited for economic and social objectives: urbanization, industry, tourism and recreation, fisheries and aquaculture, energy production and transportation. These sectoral activities produce combined environmental impacts resulting in marine and fresh water pollution, air pollution, loss of marine resources, loss of natural land resources and land degradation, destruction of historic and architectural heritage, loss of public access to the coast, noise and congestion. Natural risks and hazards, such as climatic change, earthquakes, forest fires and floods, pose additional hazards to coastal areas in the Mediterranean.

The evidence reviewed for this document shows that governmental policies to reduce or arrest coastal degradation have produced only limited results. Policies have been based on the sectoral approach and therefore failed to take into account the overall impact of coastal development on resources. Because of the sectoral approach preventive policies were difficult to develop and usually ineffective. In a few areas, where relatively high levels of co-ordination between sectoral policies were achieved, coastal resources were managed in an efficient and environmentally acceptable way. It is now generally accepted that coastal systems are far too complex to be managed through independent sectoral policies. Rather than being transferred from one sector to another, from one region to another or from one resource to another, the existing as well as potential problems should be viewed and resolved within a comprehensive environmental, social and economic management framework.

The document therefore suggests that integrated management of coastal areas is required to lay the foundation for sustainable development which will reduce or eliminate pollution, rectify other impacts, and prevent these occurring in the future. The objective of the document is to set down the guidelines for such integrated management. It is addressed in the first place to national policy makers who need to provide the necessary political will, who can create the administrative and legislative framework and who can generate the financial means to set up and operate integrated management. It also offers sufficient guidance for the authorities responsible for implementing policy in a specific coastal area.

Integrated coastal and marine areas management (ICAM) is defined as an adaptive process of resource management for sustainable development in coastal areas. Sustainable development requires that the quantity and quality of coastal resources are safeguarded in order that they not only satisfy the present needs but provide a sustained yield of economic and environmental services for future generations.

The guidelines for the ICAM process are presented in three main stages: (a) initiation; (b) preparation of the Integrated Coastal Master Plan (Planning); and (c) implementation of the Plan.

In all three stages strong political commitment at all levels of government is needed if the ICAM process is to be carried out successfully.

For the preparation of the Integrated Coastal Master Plan (stage b) four separate phases are prescribed: (i) the preparatory phase with the identification of sectoral problems; (ii) analysis including present and future uses of coastal resources and their interaction; (iii) definition of goals of ICAM and strategies; and (iv) preparation of integrated plans and policies. The most important guidelines for these phases address: the definition of the coastal area appropriate for ICAM, establishment of the institutional mechanism needed for integrated planning, creation of legal instruments needed for integration and preparation of policy instruments, and the financing mechanism for ICAM.

The implementation stage (c) is broken down into two phases: (i) implementation of plans and (ii) monitoring and evaluation of the implementation. The most important elements in these phases are the application of environmental and economic evaluation techniques, application of appropriate policy instruments, employment of the necessary enforcement mechanisms and re-evaluation and updating of the management process on the basis of monitored results. To ensure proper implementation, the guidelines propose a wide range of instruments for coastal resource management and environmental protection. In particular, they recommend the combined application of land-use controls and regulatory and economic instruments such as charges and resource pricing for pollution control and conservation.

The authority in charge of the ICAM process, the lead agency, is appointed by the government and plays a major role in ensuring that all steps in the process are carried out with the participation of all parties involved, including the private sector and the public at large. The various development ministries (industry, energy, transport, public works, tourism, agriculture and fisheries) prepare their own plans and feed them into the integration process. The lead agency, the development agencies and local authorities operate together as 'coastal area management authorities' to undertake the ICAM process.

As ICAM is a complex process with many parties involved and where conflicts can arise, specific mechanisms need to be developed for their resolution. Guidelines are developed also for the formation of ad hoc committees or permanent bodies to discuss and resolve conflicting interests. In some cases, the authorities need to set up public hearings or arbitration procedures. In this process it is important that all parties have access to legal procedures, as a last resort, to protect their rights. To an extent the integrative process incorporated into the 'coastal zone management authority' should be able to prevent serious disputes from developing.

For a closer insight into the ICAM process the document provides annexes containing definitions, description of main coastal resources, some selected examples of ICAM, and the relevant bibliography.

1. INTRODUCTION

This document is intended:

- to provide, within the context of the Barcelona Convention, general guidelines for national policy-makers, managers and professionals involved in the development and implementation of integrated coastal and marine areas management (ICAM) programmes aiming at achieving sustainable development of coastal and marine areas, including exclusive economic zones; and
- to assist in development of national guidelines for integrated coastal area management and development, and thus, contribute to the implementation of principles and recommendations adopted by the United Nations Conference on Environment and Development (Rio de Janeiro, June 1992).

The guidelines contained in this document are based primarily on the experience of the countries bordering the Mediterranean Sea, with special regard for the developing countries of the Mediterranean basin. However, it is believed that, if adapted to locally relevant conditions, they are applicable, with some adjustments, in some other parts of the world, such as the Black Sea, Eastern Africa, the Caribbean, etc. Moreover, the general principles provided in the guidelines and, in particular, those referring to the ICAM process phases, may be considered applicable world wide.

The presented guidelines are not a rigid set of prescribed steps and procedures. Rather, they represent a flexible approach consisting of alternative options serving the same goal. The choice and application of the most suitable option in a given situation will depend on the size, nature and actual circumstances of the area planned to be covered by the ICAM programme.

The document is not an exhaustive manual covering all aspects and details encountered in the ICAM process. Annex I provides definitions of the most important terms used in the document and, in addition, the reader seeking further clarification is advised to consult the publications listed in the bibliography.

2. JUSTIFICATION FOR ICAM

2.1 Common problems and conflicts in coastal areas

2.1.1 Introduction

The coastal zone is an area of intense activity, an area of interchange within and between physical, biological, social, cultural and economic processes. It is composed of multiple interacting systems: maritime, terrestrial and riverine. Changes, at any point in any part of the systems, can generate chain reactions far from their point of origin and possibly in a totally different system whose environmental conditions will be subsequently altered.

Because coastal areas are today attracting population faster than inland areas, competition is increasing over the allocation and use of coastal and marine resources, including space. Typical conflicts occur over:

- access to the coastline for some activities, such as marinas which require locations on the sea-land interface;
- incompatible uses which cannot exist in juxtaposition, such as recreation activities and aquaculture in marine areas;
- private ownership, which prevents public use of or access to coastal resources;
- long-term goals for conservation which inhibit immediate economic interests, e.g., whether to preserve or drain wetlands;
- provision of environmentally protective infrastructure in accordance with the rate of economic development, e.g., the expansion of sewage collection and treatment in keeping with hotel construction.

The current distribution of coastal resources is the result of geological, physical, biological, ecological, meteorological and other factors. Some resources are renewable, e.g., freshwater, forests and fish; others are finite or nonrenewable, such as land and sea space, oil and gas reserves and other minerals from the continental margin, some sensitive ecosystems, etc.

The sustainable use of resources can be seriously affected by man-made or natural events or processes, such as:

- impacts generated by major development projects;
- accumulative impacts generated by a number of development projects which may be individually insignificant but which together may precipitate environmental damage;
- gradual changes, such as climate change with a corresponding rise in global sea level which will particularly affect low-lying areas;

- sudden natural episodic events of immense impact, such as earthquakes; and
- sudden man-made disasters, such as major oil spills or accidental discharges of industrial wastes.

One of the fundamental features of the coastal area is that its resources, and the activities along it, have interlinked onshore and offshore components.

The sand supply to beaches is an outstanding example of this interdependence. Sand is moved by wave action from sediment sources to sediment sinks. The onshore-offshore and the longshore movements of sand determine which beaches will be supplied with sand and which eroded. This pattern is dynamic, changing day by day, by season and by year according to seasonal changes in wave patterns or as the result of intense storms or of changes in sand supply caused by construction activities.

Similarly, water-dependent habitats require an intricate mesh of saline and freshwater flows on- and offshore. Changes upstream can affect the quantity and quality of the freshwater supply, changing its biological, chemical and sediment content. Changes downstream may result from the intrusion of sea water into the aquifer and a change in clarity resulting from an influx of suspended solids. Coastal resources, dependent on a delicate balance between water flows, may suffer severe stress from changes in hydrological conditions.

The same onshore-offshore interdependence can be found in man's activities along the coastline. Oil pollution from offshore spills and domestic and industrial sewage pollution from land based sources will degrade the quality of beaches and inshore water for tourism and for aquaculture.

The interdependence of activities and resources in the coastal area explains why a sectoral approach to coastal area management has not been able to achieve satisfactory results. Each economic sector generates a range of impacts on various coastal and marine resources, but their combined impacts generate acute problems for the resource base on which their survival depends and cause conflicts between sectoral interests. A cost effective solution to one sector may be economically and environmentally detrimental to the needs of another sector. It is now therefore being recognized that effective management of coastal and marine areas should be based not only on an analysis of individual activities and their impacts, but also on the combined effects of sectoral activities on each other and on coastal resources.

2.1.2 Land and marine uses: their impacts on coastal areas

The following paragraphs identify some of the impacts of the main land and marine uses found in coastal areas.

a) Urbanization and settlement

The main impacts of urbanization and settlement relate to physical needs for space and to impacts generated by uncontrolled or untreated wastes. Irreversible impacts may include the encroachment of building on arable land, forests, open space, the beach or valuable habitats, such as wetlands. Reversible impacts may include the generation of effluents, emissions, wastes and noise which could be prevented, abated or reduced by preventive measures at source or by adequate facilities for collection, treatment and safe disposal. The need for space has generated projects for land reclamation. Shoreline modification involving infilling adjacent to the shoreline or the creation of offshore artificial islands with links to the shoreline, may cause irreversible impacts if the land reclamation is located along or adjacent to shores of high coastal and marine ecological or landscape value.

BOX 1

Urban Population in Mediterranean Coastal Areas

The Blue Plan for the Mediterranean studied the trend of urban population growth in the coastal zones of the Mediterranean. Out of five completed scenarios, data for only two are presented here (Worse Trend Scenario - WT, and Moderate Trend Scenario-MT):

Subregion	1985	WT 2025 (in thousands)	MT 2025
Northern Med. countries *	51,624	69,347	69,307
Eastern and Southern Med. countries **	30,058	101,206	81,575
Total all Med. countries	81,700	170,553	150,882

* Spain, France, Monaco, Italy, ex-Yugoslavia, Albania and Greece

** Turkey, Syria, Cyprus, Lebanon, Israel, Egypt, Libya, Tunisia, Algeria, Morocco, Malta

Source: Grenon, M. and M. Batisse (eds.). 1989. The Blue Plan: Futures for the Mediterranean Basin. Oxford University Press, Oxford.

b) **Tourism and recreation**

The impacts of tourism and recreation are similar to those of urbanization and settlement, but have some particularly problematic characteristics. Irreversible physical impacts of development may cause damage to the very resources that attract visitors, such as fragile ecosystems, vulnerable visual landscapes and valuable historic and archaeological sites.

BOX 2

Population Variations in the Mediterranean Coast of France (1988)

Seasonal variations of population are more pronounced in large tourist areas. The data given below refer to hotels, secondary homes and camping:

Region	Permanent population	Seasonal population	Increase
Languedoc-Roussillon	1,869,242	1,294,476	+69.2%
Province Alpes-Cote d'Azur	4,014,134	2,301,228	+57.3%
Corsica	243,474	270,817	+111.2%
Total	6,126,850	3,866,521	+63.1%

Source: Secretariat d'état auprès du Premier Ministre chargé de l'Environnement. 1989. La Protection de l'environnement Méditerranéen Contribution de la France.

The generation of effluents is highly seasonal - the provision of treatment facilities adequate for the massive influx of tourists for a relatively short season has often been regarded as uneconomic and unjustified by coastal communities. The tourist sector is becoming increasingly aware that protecting environmental quality is an essential basis for its own success and tourism can therefore have a positive impact by demanding adequate facilities for the prevention and treatment of pollution.

c) **Industry**

The location of industrial plants on the coastline, in ecologically sensitive or visually valuable landscapes or in areas of potential for tourism or recreation will be an irreversible impact, similar to that generated by urbanization. However, industry is an integral part of economic development in coastal areas and many of its impacts can be reduced, depending on

the type of industrial plant and the efficiency of pollution-control equipment installed. Discharge of untreated industrial effluent to marine waters, discharge of inadequately treated or untreated industrial effluent to sewerage systems incapable of treating them, gaseous and particulate emissions from industrial processes and fuel-burning, disposal of solid wastes, particularly hazardous wastes, and the generation of obnoxious odours or noise are all reversible impacts which could be restricted by imposing performance standards and reduced by control equipment at source or collected and treated before safe disposal.

d) Fisheries and aquaculture

Fishing remains a major source of nutrition in many areas. It has suffered decline largely through bad management, particularly by over-fishing; certain species, especially of shellfish, have been degraded by pollution. The need for an unpolluted marine environment for fishing has sometimes been the reason for initiating coastal zone management programmes. Recent efforts to replenish fish stocks have led to the creation of underwater artificial reefs, whose ecological impacts are not yet fully documented.

BOX 3

Mediterranean Fisheries: Present Situation

The coastal population's requirements for marine products are high (estimated at 4 m.tonnes per annum). For many years now these requirements have not been met by the Mediterranean alone. From 1938 to 1955 the catches of edible species in the Mediterranean strictly speaking (excluding the Black Sea) amounted to approximately 500,000 t per annum, and fluctuated around 700,000 t per annum from 1965 to 1973 (according to FAO). They gradually rose to 1,047,000 t in 1985 - a 48 per cent increase since 1973 - but scarcely met over one quarter of the demand. It is interesting to note that while catches in the Mediterranean are not large and amount only to 1.2 per cent of world catches, their commercial value is important since it amounts to 5 per cent of the world figure.

The countries of the North Mediterranean currently take 78.5 per cent of the total catch, compared with 21.5 per cent for those in the south. In 1985 the leading producer country was Italy (420,000 t), followed by Spain (140,000 t), Greece, Tunisia, Turkey, and Algeria, the other countries or regions each fishing less than 50,000 t. Aside from a small amount of tunnies, all catches in the Mediterranean were taken by coastal countries.

(...)

Mediterranean fishery resources are used unevenly. The demersal varieties, highly prized by consumers, are generally exploited to the maximum sustainable yield and even beyond. Thus, they cannot be expected to contribute significantly to the growth of fish production in the region. On the contrary, measures must be taken to preserve stocks, particularly through fishery supervision and protection of their reproduction and growth zones. In contrast, small pelagic species are insufficiently exploited in some regions, because they are less appreciated by consumers. A special effort should therefore be made to develop the exploitation of these species, which - along with those to be produced through aquaculture, if expectations are confirmed - could provide the basis for a substantial increase in catches.

Source: Grenon, M. and M. Batisse (eds.). 1989. *The Blue Plan: Futures for the Mediterranean Basin*. Oxford University Press, Oxford.

Aquaculture is rapidly developing activity which requires unpolluted marine space but it may be responsible for impacts of pollution and disease affecting local fish populations due to impacts of wastes, nutrients and upsetting the ecological balance for other fish species.

e) Energy production

Energy production has major irreversible physical spatial requirements on- and offshore. Plants not only require space for production, fuel supply and storage but also impose constraints on land and marine uses in their vicinity. Operational impacts include gaseous and particulate emissions, disposal of fly ash from coal burning plants, risks of oil leaks and spills, noise from

gas turbines, and some thermal pollution of seawater for cooling. Many of the operational impacts can be reduced or prevented by pollution control measures. Nuclear plants may have limited operational impacts, apart from the disposal of radioactive wastes and cooling waters, but they are a high risk activity with a low level of probability.

Renewable sources of energy (solar, wind, biomass) in general hardly generate any of these impacts. However, siting of windmills and solar panels may have negative impacts on the landscape.

f) Transportation

Road, rail, air and maritime transport have extensive spatial requirements. Not only do their linear alignments and the location of terminals and parking facilities require space, transportation facilities also impose constraints on the use of land around them by creating areas exposed to noise and pollution, and by imposing physical and ecological barriers on the land crossed by them. Maritime transport is likely to have significant impacts on coastal resources for port and channel construction and maintenance, for navigation routes, and for other sea uses. Operational impacts include noise and air pollution, and risks from the transport of hazardous wastes or oil spills.

BOX 4

Estimated Annual Incidence of Oil Pollution In the Mediterranean

Source of Pollution	Quantities (t)
Tanker operations (especially deballasting)	450,000
Oily bilge waters, sludge and used lubricating oils from ships	60,000
Ship repair (cleaning of tanks and piping)	35,000
Off-shore drilling	5,000
Pipelines	20,000
Petroleum handling installations in ports and special terminals	15,000
Navigation accidents	65,000
TOTAL:	650,000

Source: WB/EIB. Environmental Programme for the Mediterranean. Maritime Sector Assessment. Working Paper No. 4. WB/EIB.

g) Agriculture

The spatial impacts of agriculture are limited, though the draining of wetlands for agricultural use is an example of an irreversible physical impact from this activity. Agriculture is particularly responsible for the wide dispersal of non-point sources of pollution by the overuse of fertilizers, pesticides and chemical sprays which penetrate to and pollute freshwater sources, marine waters and soils, either directly or via air pollution. The over-pumping of groundwater for irrigation has resulted in the pollution of aquifers by saltwater intrusion--in some areas now irreversible. Soil erosion and salinization of land are impacts of improper farming practice.

h) Forestry

A common phenomenon which characterizes the state of forestry in many coastal zones of the world is the accelerated process of deforestation, its main effects being:

- over-exploitation: overgrazing, excessive use of wood for fuel, including the production of charcoal, and as building material;

- felling (clearance) of trees to obtain more land for agriculture, as well as for the development of industrial and tourist areas, and infrastructure;
- forest fires - natural and man-induced;
- pollution - acid rains being the recent detrimental type.

The situation is particularly alarming in the Mediterranean, ranking its forests among the most degraded in the world.

The consequences of deforestation are multiple and exceptionally harmful since forests are one of the crucial elements of any ecosystem. Their devastation affects the ecological balance formed over millenia. Endangered are, or completely extinct, the habitats of a large number of species. Economic gains which could have been realized by way of a sustainable management, are irreversibly lost, let alone the once beautiful landscapes, which are the most valuable resources for recreation, leisure and rest. Finally, deforestation directly accelerates the soil erosion processes and causes desertification.

It is apparent from the above paragraphs that the combined impacts of several economic sectors on coastal resources may be far more severe than the impacts of each sector alone. Moreover, the damage to, or deterioration of coastal resources generated by one sector may undermine the resource potential or survival of another. Some of the impacts may be irreversible, permanently changing the quantity or quality of coastal resources. Others may be temporary and can be alleviated or abated without causing any long-term effects on, or alterations to the coastal resource base.

2.1.3 How economic activities affect coastal resources

The following paragraphs identify how coastal resources are affected by economic activities and indicate the kind of measures which can be taken to prevent the damage to, or deterioration of coastal resources.

a) Marine pollution

Most marine pollution is from land-based sources: domestic and industrial effluents, drainage from agricultural run-off, stormwater run-off in urban areas, or from solid waste disposal, airborne sources of pollution, and sediments from erosion or land reclamation. Marine sources of pollution are operational discharges (waste and ballast) from marine transport and accidental discharges, including spills. The severity of the effects on coastal resources will depend on the composition of the pollution (nutrients, toxic substances), their quantity and level of concentration, and on hydrological conditions in the recipient waters.

Damage from marine pollution can affect the health of local residents, reduce attractiveness to tourism and recreation, damage marine ecosystems, reduce revenues from fisheries and aquaculture and reduce coastal property values. While zero marine pollution is an unrealistic objective, the adequate prevention or collection and treatment of all wastes and effluents would very considerably reduce levels of marine pollution.

b) Freshwater pollution

Freshwater is polluted by the same land-based sources as marine pollution, but also by non-point sources from agriculture and by the intrusion of seawater into the coastal aquifer.

The most serious consequence of freshwater pollution is the loss of safe drinking water. Pollution of surface water bodies may also give rise to a health risk and may reduce attractiveness to recreation if accompanied by odour.

Adequate prevention, or collection and treatment of all wastes and effluents is essential. Further steps could be taken to protect freshwater catchment areas from polluting activities by

imposing restrictions on the use of fertilizers and pesticides and by preventing excess extraction of water from coastal aquifers because it takes decades for a polluted aquifer to recover.

BOX 5
The Island of Rhodes:
Estimate of Impact of Coastal Activities on the Environment
(in million US\$)
Main Problem Areas

Area	Source	Activity involved	Loss of tourist revenue	Loss of fisheries	Degradation of the beach	Human health hazard	Residential amenity	TOTAL
1 Bay of Ixia	Liquid waste sea disposal	Hotels, Restaurants, Second Homes	6.0	N.A.	0.5	0.5	1.0	8.0
2 Faliraki coast	Liquid waste sea disposal/ overutilization of ground water	Hotels, Restaurants, Second homes	1.0	N.A.	0.2	0.2	0.5	1.9
3 Port Area	Liquid waste sea disposal	Industry, Transport, Commercial, Residential	0.5	N.A.	1.0	0.1	-	1.6
4 City of Rhodes	Liquid waste sea disposal	Hotels, Residential, Commercial	0.6	N.A.	1.0	0.1	2.0	3.7
TOTAL			8.1	-	2.7	0.9	5.2	13.5

Source: UNEP. 1993. Cost and Benefits of Measures for the Reduction of Degradation of the Environment from Land-Based Sources of Pollution in Coastal Areas. UNEP, Athens

c) Air pollution

Air pollution from industry, energy production, traffic and heating facilities consists of gaseous emissions, particulates and odour. Under certain conditions, photochemical smog develops.

The severity of the effects on air quality will depend on the composition of the emissions, their quantity, their concentration, the height at which they are emitted and the topographical and meteorological conditions for dispersal. Several coastal areas suffer particularly from a heavy concentration of air pollution sources and others from smog where dispersal conditions are inadequate.

Damage from air pollution is predominantly to the health of local inhabitants, but it may also degrade the quality of the environment for tourism and result in damage to historic buildings and monuments. Air pollution is also an indirect cause of marine pollution.

Air pollution can be prevented by well established technological measures. Filters and scrubbers can be incorporated at point sources and restrictions can be imposed on the sulphur content of fuels burned. Non-point sources are more difficult to control, especially in relation to traffic and the use of agrochemicals. Pollution generated by road traffic can be reduced by

technical measures (use of catalytic converters), but measures will still be needed to reduce traffic movement, e.g., by the encouragement of public transport.

BOX 6

Loss of Wetlands in the Mediterranean

The greatest threat to the remaining wetlands of the region is modification of their hydrology by dyking and the diversion of the water for irrigation. In Spain, for example, the internationally recognized Tablas de Daimiel and the Coto Donana, perhaps the most important wetlands in Western Europe for the conservation of biodiversity, are suffering rapid and serious changes to their hydrology. In the case of the Coto, the water is being pumped from the aquifer of Almonté to grow strawberries in March for the north European market.

In the southern countries of the Mediterranean the rate of change is slower but accelerating, and the pattern similar. The important Algerian wetland complex, El Kala, is threatened by plans to build the Mexanna Dam, which would take water from Lac Oubiera and eventually dry up the Garaet el Makhada. Intensification of traditional fish and wildlife harvests at El Kala also pose new threats. Increased fishing on Lac Oubiera and Lac Mellah will cause serious disturbance to the wildfowl populations. Hunting pressure is high on Tonga, Oubiera and particularly intense on the Garaet el Makhada, despite its National Park status.

Similar developments have been reported from Lake Ichkeul in Tunisia, and the Akrotiri salt lake in Cyprus. The situation is particularly alarming at Ichkeul, where significant vegetation changes have already been observed in response to increasing salinity and changing water levels. The wildlife value of this critical wetland will be lost unless the management plan is rapidly implemented. In the Gulf of Gabes, also in Tunisia, intertidal refuse dumps are causing pollution and wetland habitat loss. There is heavy metal pollution from local industries, and the oil refinery at Es Skhirs is potentially a major source of pollution.

All these problems, with the addition of eutrophication and illegal hunting, occur to serious degrees in the two large Egyptian wetlands - the Sebket el Bardawil and Buharet ei Manzala.

In Turkey, the Camalti Tuzlasi is threatened by proposed plans to extend the existing salt works, and the Goksu Deltasi is threatened by plans to expand tourism in the area. Uncontrolled hunting is a problem at both sites.

These examples of the problems being faced by some of the key wetlands in the area could, unfortunately, be multiplied. They indicate a need for swift and effective action to protect the rapidly dwindling wetlands of the Mediterranean Basin. Carefully controlled development programmes will be needed and an increase in the level of effectiveness of legal protection is essential. Enforcement of existing rules and regulations will be a vital first step, though none of this will be achieved without a higher level of political commitment than has been shown in the past.

Source: WB/EIB. Environmental Programme for the Mediterranean. Natural Resources Management. Working Paper No.2. WB/EIB.

d) Loss of marine resources

Physical changes to marine resources by land reclamation and construction activities or by severe pollution can result in a permanent loss. Damage to living marine resources can cause a loss of revenue to the fishing sector and a loss of ecological resources of value for nature conservation.

Marine and coastal ecosystems, particularly wetlands and sea grass beds, are important as spawning grounds and nurseries for many commercially valuable species, of high value for nature conservation and for the preservation of biodiversity, and are potential habitats for aquaculture. Wetlands are vulnerable to surface alterations and changes in hydrologic patterns which disrupt their functioning. They can be protected by carefully defined and controlled management regimes.

Loss of sand or beach material is also a loss of a marine resource. It is frequently the direct result of extraction for building materials or the indirect result of man-made interference in natural beach processes. Construction of coast protection and sea defense works or harbours and breakwaters for marine transport and marinas can easily interrupt sediment transport, resulting in a reduced supply of beach material, loss of beach width, and exposure of property to flood damage. Preventive measures are based on principles of working with, not against, natural processes and imposing restrictions on offshore and onshore construction. The extraction of beach material can simply be stopped by regulation.

e) Loss of land resources of natural and visual value

Coastal resources of especially high natural and visual value include (in addition to wetlands) river mouths, forests, dunes and rocky shores with headlands and bays. Urban, tourist, industrial or other physical development may disturb or degrade the special characteristics of the land resources by earthworks or by incongruous or monotonous development. They may also deplete the supply of green open spaces separating built up areas and reduce the land options left open for future generations. Insensitive development will ultimately result in a loss of attraction for tourism. Some damage may be remedied by landscape reclamation or rehabilitation, harnessing damaged resources for new coastal uses. Others will be a permanent loss of resources, where no technology can stop the damage or replace the loss of open spaces. Many countries now recognize the importance of protecting green open spaces, and designate a considerable proportion of coastal land to be preserved for this and future generations.

f) Loss of historic and archaeological resources

The heritage of cultural resources are found both on- and offshore where each civilization has left its remains. Ancient or traditional forms of building, historic sites and monuments and archaeological remains are easily damaged by:

- demolition - where their importance has not been recognized or where property values are high;
- neglect through abandonment and by the lack of funds for maintenance;
- inappropriate additions where population density necessitates the creation of extra living space;
- concealment by new building; and
- corrosion of natural stone structures as a result of air pollution.

Historic and ancient structures are also readily damaged by seismic activity. The loss of such cultural resources represents a loss of the human and cultural heritage for present and future generations and a loss of tourism attractions.

Preventive measures include identifying and regulating sites which should not be allocated for any type of development, encouraging new but compatible uses which could maintain old buildings, imposing restrictions on construction height and building materials in historic areas, and rehabilitating structures damaged by air pollution, marine corrosion or tectonic movement.

g) Public access to space and resources

Many of the problems and conflicts in coastal areas centre around the issue of what constitutes public or common property. In many countries, access to the coast is regarded as a public right, and any restriction of public access is a loss of resource, whether the land is actually in private or public ownership. In other countries marine resources, particularly fish, are regarded as common property to be retained by whoever captures them. The use of the sea as a communal basin for waste disposal reflects the attitude that coastal and marine resources are common property. Practices vary about resources found under the land: underground water sources and

minerals may be considered common property or they may belong to the owner of the land surface.

This document proposes that access rights should be secured for the public to certain coastal and marine resources, while respecting property rights and traditional uses and practices. The access rights may vary between countries but will usually include a right of physical access along the seashore and a right of access, as frequently as possible, from inland to the seashore. These may be secured by public purchase or easements. Public access rights to coastal and marine resources (fish, water, minerals) have to be regulated to prevent mismanagement and over- exploitation.

Restrictions on public access to space and resources can have environmental costs and benefits. Loss of public access means loss of opportunities to local residents and visitors but certain constraints on public access may be environmentally beneficial by acting to protect fragile resources.

h) Noise and congestion

Noise and congestion are temporary effects which degrade, but do not damage, coastal resources. They are most commonly generated by traffic and transportation (road, rail and aircraft movements) but are also generated by industry and occur at major concentrations of public activity (sports, entertainment, etc.).

Noise can easily be abated within buildings by acoustic treatment of openings and by the use of appropriate building materials. Noise abatement in open areas is not easy to achieve; noise barriers can be used to create "acoustic shadows." However, in coastal areas with mild or hot climates, where much social activity takes place outdoors and late at night, noise can be a significant environmental disturbance to residential areas.

2.1.4 Summary of interactions between coastal uses, activities and resources

Table 1. presents in a concise way the possible interactions which may be significant in coastal and marine areas. The arrows point in the direction of the likely interaction: activities may have effects on resources, or damaged resources may limit activities, or the interactions may be both ways.

The strength or significance of the interaction is indicated as follows:

← A significant interaction

↔ A highly significant interaction

An explanation of the interactions is given in the text (2.1.1; 2.1.2). The possible preventive actions indicate what types of solutions may be appropriate (elaborated in 2.1.3). The interactions presented in the matrix are those likely to be found in the Mediterranean area, and may vary from country to country and between subnational regions.

Activities Effects	Urbanization	Tourism	Industry	Energy Production	Fisheries & Aquaculture	Transport	Forestry	Agriculture	Possible Preventive Actions
Marine pollution	↑↑ ↑↑	↑↑ ↑↑	↑↑	↑↑	↑↑ ↑↑	↑↑	↑↑	↑↑	Adequate facilities of effluent collection and treatment. Restrictions on non-point sources
Freshwater pollution	↑↑ ↑↑	↑↑ ↑↑	↑↑	↑↑	↑↑ ↑↑	↑↑	↑↑	↑↑	As above and protection of water catchment areas Prevention of overpumping
Air pollution	↑↑ ↑↑	↑↑ ↑↑	↑↑	↑↑		↑↑	↑↑	↑↑	Pollution abatement equipment Restrictions on fuels burned. Encouragement of public transport
Loss of marine resources	↑↑	↑↑ ↑↑	↑↑	↑↑	↑↑ ↑↑	↑↑	↑↑	↑↑	Management of fisheries Designation of marine reserves Restrictions on extraction Encourage natural beach processes
Loss of land resources	↑↑	↑↑ ↑↑	↑↑	↑↑		↑↑		↑↑	Designation of protected areas Protect open spaces Rehabilitate damaged open spaces Keep spatial options open
Loss of cultural resources	↑↑	↑↑ ↑↑	↑↑	↑↑		↑↑			Designation of sites, buildings & monuments Encouragement of new, compatible uses Restrictions on building height and materials Rehabilitation of stone damaged by corrosion
Loss of public access	↑↑	↑↑ ↑↑	↑↑	↑↑	↑↑	↑↑			Regulations to guarantee public right of access Prevention of obstacles to access Clear definition of public and private rights to resources
Soil degradation	↑↑		↑↑	↑↑			↑↑	↑↑	Air pollution abatement equipment Good farming practice to prevent soil erosion
Noise and congestion	↑↑ ↑↑	↑↑ ↑↑	↑↑	↑↑		↑↑			Noise abatement equipment at source Acoustic building and acoustic barriers Restrictions on locations of noise sensitive activities

Table 1. Matrix Of Possible Interactions Between Economic Activities And Effects On Coastal Resources

2.1.5 Climate change

According to broad scientific consensus, "greenhouse gases" (CO₂, CH₄, N₂O, chloro-fluorocarbons) generated by human activities have already accumulated in the atmosphere to such a level that climate change may have started, and its continuation may now be inevitable. The increase of greenhouse gases over the last 100 years may cause global warming in the range of 0.4-1.1°C, and predictions suggest that temperatures may increase by 1.5-4.0°C in 20 to 30 years.

One of the major effects of global warming is a rise in sea level due to the melting of glaciers and thermal expansion of oceanic waters. It is known that in the recent historical period the sea level has been rising at a rate of 0.5 - 1.5 cm a year. Estimates for the future indicate a possible rise of 13 - 39 cm by the year 2025, and 24 - 52 cm by 2050. Interacting with these changes will be the effects of local tectonic activity and subsidence.

The rises in temperature and in global sea level could affect coastal and marine areas, particularly in relation to:

- surface and groundwater flow and river regimes (water supply availability, incidence of floods and sediment transport);
- movement of main water masses (waves, currents, tides, erosion of the coastline, tidal range);
- natural ecosystems due to increased temperature and exposure to climatic extremes;
- change in the frequency and intensity of extreme events (storms, floods, winds, draughts);
- occupation and use of coastal land due to sea-level rise.

The impacts of such changes may include:

- an increased seawater intrusion into the coastal aquifers;
- further difficulties in obtaining freshwater;
- changes in fisheries and aquaculture production;
- increased inundation under storm conditions in unprotected coastlines and low-lying areas;
- increased shore erosion;
- loss of natural vegetation in marginal climatic zones or areas of poor soil;
- possible increased risk of forest fires; and
- alteration of the biodiversity composition and structure.

With a gradual increase in temperature and changes in precipitation, vegetation belts may shift northward. Another possible effect may be an extension of the tourist season, with consequent economic benefits together with an increased pollution load.

By the middle of the next century, damage to coastal settlements, harbours, coastal roads, and other infrastructural features could be considerable as most of these developments are only slightly above the present mean sea level.

2.1.6 Risks and hazards

Natural, man-induced and man-made risks and hazards have to be taken into account in ICAM.

Natural risks are not necessarily predictable though their probability may be known and those areas most exposed to risk can be identified. Such risks include seismic activity, flooding, tsunamis (tidal waves), landslides and volcanic eruptions. In some high-risk exposure areas, previous experience has already indicated what steps should be taken to reduce the loss to life

and property. Some countries have adapted to the known risks and already incorporate risk management measures in their policies for coastal and marine areas. Elsewhere, scientific knowledge and experience are well known, administrative steps may already have been taken (e.g., building codes), but lack of implementation has resulted in inappropriate development in high risk exposure areas. Experience shows that where preventive measures have not been taken (e.g., residential development not in accordance with building codes in seismic risk areas) or where historic or ancient monuments are located in high risk areas, large financial investment is needed over a long period of time to reduce risk levels.

A number of coastal areas are seismically active zones, affected by earthquakes. Due to the present trends of urbanization and development, the possibility of severe damage to people and settlements has enormously increased. A prerequisite for the mitigation of the seismic risk is the existence of a national policy defining the process of seismic risk management and the roles of involved authorities and other parties. An assessment of seismic risk within ICAM is indispensable, requiring land-use planning based on macro and micro zoning of seismic prone areas and building methods and standards which provide for seismic events.

Coastal cliff instability is partly a natural risk and partly man-induced. Coastal cliff shores are dynamic: the rate of cliff recession depends on rock resistance, cliff-top drainage, wave energy, and whether or not there are natural or man-made forms of protection. Disturbing the cliff by earthworks, changes to drainage patterns, excavation or removal of vegetation may cause destabilization. The zone along a cliff head may collapse and the zone along a cliff toe may be subject to rockfalls.

Measures can be taken to prevent encroachment of building in the unstable areas at cliff head and toe, to channel surface drainage away from the cliff face, and to design recreational and tourist development of cliff shores to include cliff stabilization measures which would not transfer the problem of instability up- or downshore.

The risk of forest fires is more man-induced than natural. Forest fires occur frequently in coastal areas, especially in arid and semi-arid areas and in those with high summer temperatures. In populated regions, they are most often due to human factors (negligence, arson), sometimes due to natural causes (lightning, spontaneous combustion), and often due to a combination of factors, (e.g., storm, sparks from electricity lines and an abundance of undergrowth). Fire risk and the extent of damage are often increased by unfavourable topographic conditions and strong winds, and difficulty of access for fire fighting equipment. According to the FAO, forests and woodlands lost to fire in nine countries of the northern and eastern Mediterranean in 1988 exceeded 570,000 ha, accounting for an annual loss of US\$500 million. Due to low productivity and insufficiently exploited economic possibilities of coastal forests, the local population is rarely interested in their protection. Forest fires can have other consequences, such as ecosystem damage, threat to biodiversity, and degradation of vegetation cover, and may contribute to an acceleration of erosion processes leading to the eventual loss of the soil layer.

Technical hazards are man-made. Some of those that occurred in the recent past had catastrophic dimensions (Chernobyl, Bhopal, Seveso, etc.). While all possible preventive measures may have been taken, there will still remain a degree of risk from industrial processes which include hazardous substances, their storage and safe disposal. The risk of accidents and the areas likely to be exposed to technical hazards and risks should be taken into account in ICAM.

2.2 The need for and the concept of ICAM

2.2.1 The need for ICAM

Managing complex systems requires an integrated approach capable of bringing together the multiple, interwoven, overlapping interests of the coastal area in a coordinated and rational manner, harnessing coastal resources for optimum social and economic benefit for present and future generations without prejudicing the resource base itself and maintaining the ecological processes.

Coastal resources cannot be used by any interest group as their exclusive right. The sea cannot be regarded as a common basin for effluent disposal, nor can air sheds be regarded as available capacity for air pollution. Almost all coastal and marine areas produce or support multiple products and services. Sectoral solutions usually "transfer" the problem between resources, products and services. Tourism will not flourish if the area loses its attraction to visitors; fisheries are usually on the receiving end of everyone else's problems. Industry and energy facilities can degrade the environment for all other activities. There is, therefore, a need to bring sectoral activities together to achieve a commonly acceptable coastal management framework.

BOX 7

The Urgency for and Benefits of ICAM

The need for coastal states to accelerate the development of capabilities for integrated coastal area management arises because:

- current trends of increasing poverty in coastal communities are resulting in degradation of the coastal area and deterioration of the quality of life;
- current pressures from development and population are increasing land-based sources of marine pollution and human intervention with river basins, adversely affecting coastal processes.

The pressures include:

- accelerating the decline of habitat and natural resources, including beaches, mangroves, wetlands, corals and sea grasses, as well as fisheries and other coastal and marine resources; and
- increasing vulnerability to pollution, beach loss, habitat loss, natural hazards and long-term impacts of global climate change.

The changes may, in turn, limit options for future development:

- many degraded and threatened coastal resources and ecosystems are in need of rehabilitation and restoration;
- efforts to develop capabilities for integrated coastal area management and implement national programmes may take 10 years or more; and
- implementing strategies for adapting to and mitigating the impacts of global climate change may require lead times of several decades and longer even if immediate measures to reduce greenhouse gas emissions are taken.

(...)

The implementation of ICAM can stimulate and guide the sustainable development of coastal areas; it can minimize the degradation of the natural system, provide a framework for the management of multi-sectoral activities and maintain options for future uses of resources. As coastal states develop the capabilities for and implement integrated management of their coastal resources, they provide local and national benefits, including enhancing economic development and improving the quality of life. These benefits are achieved through the protection of the environment (e.g. water quality, biodiversity, and adaptation to climate change). Thus, ICZM contributes to the protection and sustainable use of the earth's coastal resources.

Source: World Coast 2000. 1993. Preparing to meet the coastal challenges of the 21st Century: Conference statement. Nordwijk, The Netherlands.

As pressures increase, problems can no longer be transferred. The transfer of coastal erosion downshore, or water pollution downstream, or air pollution dispersed further afield by ever higher smoke stacks are not acceptable solutions to coastal conflicts. Mechanisms have to be created within economic and social systems to ensure that environmental costs are incorporated into economic evaluations and not passed on to other areas or to future generations. These mechanisms will need to fit the complexity of coastal systems. An integrated approach aims to bring together the conflicting demands of society for products and services, anticipating current and future short, medium and longterm interests. It has to maintain options open for future uses of marine and coastal resources and be capable of responding to uncertainty.

It, therefore, requires far more extensive analysis than the sectoral approach, and by incorporating external effects, it should generate economically, socially and ecologically acceptable policies for coastal and marine management.

The foregoing paragraphs justify why the management of marine and coastal resources needs an integrated approach - ICAM.

2.2.2 The principles and concept of ICAM

ICAM is a continuous, proactive and adaptive process of resource management for environmentally sustainable development in coastal areas. More specific coast and marine related principles have been extensively elaborated elsewhere, two of which are presented in Boxes 8 and 9.

BOX 8

Some Principles for ICAM

1. The coastal area is a unique resource system which requires special management and planning approaches
2. Water is the major integrating force in coastal resource systems
3. It is essential that land and sea uses be planned and managed in combination
4. The edge of the sea is the focal point of coastal management programmes
5. Coastal management boundaries should be issue-based and adaptive
6. A major emphasis of coastal resources management is to conserve common property resources
7. Prevention of damage from natural hazards and conservation of natural resources should be combined in ICAM programmes
8. All levels of government within a country must be involved in coastal management and planning
9. The nature-synchronous approach to development is especially appropriate for the coast
10. Special forms of economic and social benefit evaluation and public participation are used in coastal management programmes
11. Conservation for sustainable use is a major goal of coastal resources management
12. Multiple-use management is appropriate for most coastal resource systems
13. Multiple-sector involvement is essential to sustainable use of coastal resources
14. Traditional resource management should be respected
15. The environmental impact assessment approach is essential to effective coastal management

Source: Clark, J.R. 1992. Integrated Management of Coastal Zones. FAO Fisheries Technical Paper No.327. FAO, Rome

ICAM is not a substitute for sectoral planning, but focuses on the linkages between sectoral activities to achieve more comprehensive goals. ICAM seeks to:

- identify where resources can be harnessed without causing degradation or depletion;
- renew or rehabilitate damaged resources for traditional or new uses;

- guide the level of uses or intervention so as not to exceed the carrying capacity of the resource base;
- ensure the integrity of coastal ecosystems' biodiversity;
- ensure that the rate of loss does not exceed the rate of replenishment;
- reduce risks to vulnerable resources;
- respect natural dynamic coastal processes, encouraging beneficial ones and preventing adverse interferences;
- encourage complementary rather than competitive activities;
- ensure that environmental and economic objectives are achieved at tolerable cost to society;
- develop human resources and strengthen institutional capacities;
- preserve and promote social equity and introduce the participatory approach;
- protect traditional uses and rights and equitable access to coastal resources.

Fundamental to ICAM is the comprehensive understanding of the relationships between coastal resources, their uses and the mutual impacts of development on the economy and the environment. These relationships need to be understood and expressed not only in physical and environmental terms, but also in economic terms. They are important in planning, policy formulation, implementation and performance evaluation. As coastal resources are used simultaneously by the different economic and social sectors, integrated management can only be accomplished when all these uses, users and relationships are clearly known. It is therefore far wider than static land use planning, requiring a multi-disciplinary approach to the management of dynamic processes in the terrestrial and marine environments.

ICAM should focus on facilitating horizontal and vertical dialogue, agreements and compromises between all parties involved in the use of coastal and marine resources. It is a participatory process which involves strategic planning that considers local values, traditions, needs and priorities to define overall priorities and objectives for the development and management of coastal areas. Issues of land tenure and property rights should also be considered within the process of integrated coastal management. Finally, although the principles and methodological approach adopted in ICAM have a general value, each country will need to interpret and apply ICAM in its own national and local context.

BOX 9

Objectives of Integrated Coastal Area Management

ICAM focusses on three operational objectives:

- strengthening sectoral management, for instance through training, legislation, staffing;
- preserving and protecting the productivity and biological diversity of coastal ecosystems, mainly through prevention of habitat destruction, pollution and overexploitation;
- promoting rational development and sustainable utilisation of coastal resources.

Source: The World Bank. 1993. The Noordwijk Guidelines for Integrated Coastal Zone Management. Washington DC, USA.

2.2.3 Guidelines for sectoral policies in the context of ICAM

On the basis of the analysis of common coastal problems and conflicts, the following guidelines are suggested:

- Urban growth should be coordinated with the available capacity of infrastructure: uses should not be permitted beyond the absorbing capacity of available services.
- The location and operation of industrial facilities should be controlled to prevent adverse impacts on tourism and on natural resources, and be required to incorporate measures for the prevention or abatement of water, land, air and noise pollution.
- Tourism should be integrated with policies for development with nature and landscape protection, in a way which contributes, through revenue generation, to the protection and improvement of the very environment which attracts visitors.
- Areas for aquaculture should be allocated with due consideration to other coastal activities and to existing or possible discharges to marine waters.
- Facilities for fishing should be maintained, with appropriate controls for the protection of fish stocks and of marine nature reserves.
- Coastal agricultural use should be maintained not only for food production and employment but also for landscape management and as a valid use of open space for the purpose of separating urban centres and preventing continuous development along the shore.
- Open spaces should be maintained to separate urban centres and to ensure the protection of natural and landscape coastal resources.
- Development should not be permitted to encroach on the shoreline; the immediate coastal strip (whose width will vary according to natural conditions and to social and economic requirements) should remain free of construction and be recognized as far as possible as rightfully open to public access.

3. THE DEVELOPMENT AND IMPLEMENTATION OF ICAM

3.1 Approaches to ICAM

Most examples of ICAM to date have been generated at central government level, taking responsibility for marine and coastal resources for society as a whole. It is a top-down approach which, to be successfully implemented, requires the cooperation of local coastal communities. In some countries outside the Mediterranean area, local initiatives have generated a bottom-up approach where local stakeholders perceived that their local interests were being directly affected by coastal and marine activities.

BOX 10

"Top-down" and "bottom-up" approaches to ICAM

The extent of involvement of government and local groups in providing the initial leadership for ICAM differs widely among nations. For the discussion here, efforts initiated by central government are called "top-down", while those initiated by local groups are called "bottom-up". In the twenty cases examined, the majority were initiated by a "top-down" approach. This was true for both urban and rural settings, and for areas characterized by both traditional and modern cultural practices. All of the areas with market economies featured top-down approaches. Of the areas with subsistence economies, 60% featured "top-down" approaches, and 40% featured "bottom-up" approaches. This suggests that local groups are most willing to act, as they do in subsistence economies, when they perceive themselves to be direct stakeholders. A key to involving local groups in ICAM planning and implementation, then, appears to be enhancing awareness of the benefits of cooperation.

In general, the degree of government involvement in initiating ICAM appears to depend on the extent to which the resources being managed are viewed as public goods. Access to fresh water is often viewed as a personal right, by farmers and city dwellers alike, and thus tends to elicit more personal involvement from citizens. Access to fisheries tends to be seen as a collective right, and thus appears to more naturally involve central government leadership. Programmes with long histories tend to show increasing balance between government and local leadership as they evolve, regardless of how they are initiated.

The geographic setting also seemed to have some relationship to whether initiation was "top-down" or "bottom-up". All of the island nations examined in the case studies featured a "top-down" approach. Of the continental shore cases, 90% followed the same pattern. This may be partially attributed to the pressure from international agencies to initiate ICAM efforts, since these pressures are usually applied to central governments.

In general, the distribution of coastal resources appears to play a role in determining the level of government involvement. Issues involving local resources are more commonly taken on by local groups, who perceive greater direct benefits than they do for resources that benefit the society at large. Resources which are widely and evenly distributed tend to elicit a central government-driven management approach.

Source: World Coast 2000. 1993. Preparing to Meet the Coastal Challenges of the 21st Century: Conference Report. Noordwijk, The Netherlands.

Even where a government-sponsored approach is adopted, the intrinsic nature of ICAM requires the active involvement of local communities and stakeholders, bringing the top-down and bottom-up approaches together in a synergistic framework.

Though ICAM is in many cases a government sponsored, long term process, the private sector should play an important role in furthering sustainable development in the coastal region. Private investment can be harnessed with incentives as necessary, to contribute to implementing appropriate development programmes in accordance with ICAM whereas inappropriate short term private investment should be deterred.

3.2 Stages of the ICAM process

In coastal areas, where accommodation to rapid change is often required, flexible decision making calls for a continuous process of planning, implementation and goal-adjustment. In resource management process, such as ICAM, decisions are being taken in three separate stages: initiation, planning and implementation.

Initiation of ICAM includes the analysis of triggering factors which could strengthen public awareness of coastal issues and the need to take actions in coastal areas.

Planning in ICAM refers to the development of policies and goals, and selection of concrete sets of actions (strategies) to produce the desired mix of goods and services from the coastal area over time. It is a goal-directed decision-making process involving the ability to anticipate future events, a capability for analyzing and evaluating situations, and a capacity for innovative thinking to derive satisfactory solutions.

Implementation is the vehicle through which the plan is put into effect. It is the process of operational decision-making, working towards the objectives of the plan through interaction with relevant administrative, legal, financial and social structures, and with the public participation.

These three stages of ICAM contain the following phases:

- Initiation: initiation of ICAM;
- Planning: preparatory phase; analysis and forecasting; definition of goals and strategies; integration of detailed plans and management policies;
- Implementation: implementation of plans; monitoring and evaluation.

The management process requires that its phases be cyclically repeated. The results of the operative phases are constantly monitored, and the links between various phases include feedback mechanisms ensuring timely correction of activities which, on the basis of monitoring and evaluation, may have taken a wrong direction. Table 2 indicates the major stages and phases of the ICAM process, together with activities, outputs, types of political decisions, and sectoral activities relevant to each phase of the process. Figure 1 shows how the links between major phases of the process are established, with feedback mechanisms having a prominent role.

Sectoral inputs	Stages	Phases	Activities	Outputs	Political decisions
Triggers: past decisions, new decisions, external influences	INITIATION	<i>INITIATION OF ICAM</i>	Analysis of prerequisites for ICAM Tentative boundaries of the area Preparation of the proposal for initiation of ICAM	Proposal for the preparatory phase of ICAM	To start ICAM
Sectoral Problem identification	PLANNING	<i>PREPARATORY ACTIVITIES</i>	Definition of coastal area. Identification of sectoral and cross sectoral problems. Proposal for general goals and objectives Preparation of development environment, outlooks and tentative strategy. Identification of information gaps. Definition of legal financial and institutional requirements for ICAM Proposal for integrated Coastal Master Plan preparation procedure.	Coastal Profile. ICAM programme.	To establish ICAM as a continuous and long term process
Sectoral analysis and forecasting		<i>ANALYSIS AND FORECASTING</i>	Issue -oriented new surveys (generation of missing primary data) Analysis of natural and socio economic systems. Forecasting of future demand. Generation of cross sectoral scenario and selection of preferred scenario.	Alternative scenarios	
Definition of sectoral goals and strategies		<i>DEFINITION OF GOALS AND STRATEGIES</i>	Proposal for sectoral and cross sectoral goals and objectives. Preparation of alternative strategies including, legal requirements, financial implications and institutional arrangements. Evaluation and selection of strategy.	Management strategy	Approval of goals objectives and strategies
Sectoral plans		<i>INTEGRATION OF DETAILED PLANS</i>	Allocation of land and sea uses Proposal for implementation procedures (legal, institutional, financial) and relevant instruments (EIA, CBA, etc) Definition of implementation stages Draft Integrated Coastal Master Plan presented to relevant body for approval	Integrated Coastal Master Plan	Adoption of Integrated Coastal Master Plan and relevant policies
Sectoral plans and policies	IMPLEMENTATION	<i>IMPLEMENTATION OF PLANS</i>	Phasing of ICAM proposals and policies. Application of economic, regulatory, and environmental evaluation instruments in development control Adaptation of institutions to ICAM.	EIA CBA	Approval of implementation instruments used in the development control process
Sectoral monitoring		<i>MONITORING AND EVALUATION</i>	Redefinition of cross sectoral problems Identification of inadequacy of instruments	Evaluation study	Update of ICAM process

Table 2. STAGES, PHASES, ACTIVITIES AND OUTPUTS OF THE ICAM PROCESS

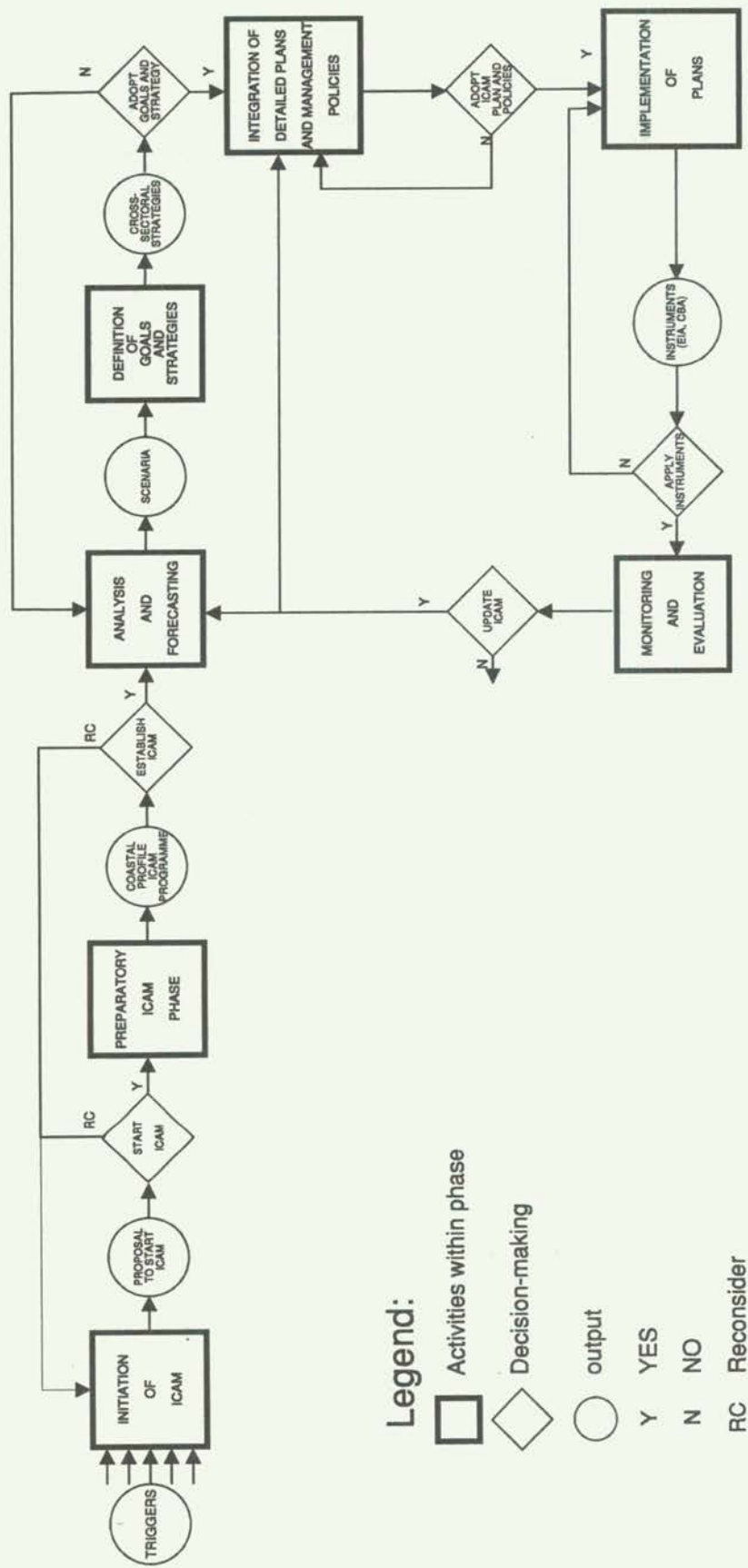

Legend:

- Activities within phase
- ◇ Decision-making
- output
- Y YES
- N NO
- RC Reconsider

Figure 1. FLOWCHART FOR INTEGRATED COASTAL AND MARINE AREAS MANAGEMENT (ICAM) PROCESS

BOX 11

Integrated Coastal Area Management Programme for the Syrian Coastal Area

The Syrian coastal zone covers 4,190 sq km, with a coastline 210 km long. It accounts for 2% of the national territory of the Syrian Arab Republic, and accommodates approximately 1.2 million inhabitants (11% of the population of the country). The zone is composed of 3 markedly different areas: the coastal plain, abundant with water and fertile soil; the hilly zone with limited water resources and lower quality agricultural land; and the mountains. About 12% of the GNP is generated in this coastal zone.

An intensive development of basic economic activities and infrastructure in the coastal region affected its physical environment and caused a still increasing population pressure on the narrow coastal strip and major cities (Lattakia, Banyas, Tartous). Such a development pushed the limited and highly fragile coastal resources towards degradation: high pollution of fresh water resources, degradation of soils, loss of fertile soils to suburban development, sea and air pollution, intensive illegal building of secondary homes.

Fully aware of the ever growing problems of this area, MAP and the Syrian authorities started in 1988 a pilot action on integrated management of the region within the Priority Actions Programme. Upon request of the Syrian Government, an Agreement, relative to the implementation of a comprehensive Coastal Area Management Programme for the Coastal Region of Syria, was signed between Syria and MAP in 1990. This Programme comprised a number of inter-linked activities: implementation of the Protocols of the Barcelona Convention, monitoring of the marine environment, application of tools and techniques of coastal management (assessment of impacts of expected climate changes, application of EIA and GIS, preparation of environment-development scenarios), preparation of an Integrated Management Study, and, finally, of a Coastal Resources Management Plan (CRMP). In all those activities, particular emphasis was placed on training of national experts and institutions, and most of the Programme was implemented by national teams in cooperation with international experts.

Apart from the plan of management and protection of coastal resources, elaborated in detail, the CRMP contains a number of recommendations to the Government and local institutions for institutional changes, bringing legal instruments, and immediate actions. In 1992-93, some of the recommendations were implemented. These had to do with institutional changes, introduction of appropriate legal instruments and some management tools and techniques, and the protection of some important resources by means of a number of concrete actions.

The triggering factors, in this case, were:

- general awareness of the worrying state of environment, and the threat to, and inadequate use of, coastal resources;
- the will of the relevant authorities (represented by the Ministry of the Environment) to stop the negative processes and to create conditions for sustainable development;
- the initiative of international institutions (in this case MAP-UNEP), followed by assistance and financial support for the implementation of the Programme.

3.2.1 Initiation of the ICAM process

Coastal and marine areas management practice in many countries shows that there are a number of triggering factors that could play the dominant role in the initiation of the ICAM process, such as:

- past decisions resulting in environmental degradation, accidents, multiple use conflicts or other problems;
- new decisions, particularly those that initiate major projects whose impact needs to be examined within ICAM;
- external influences such as international consensus to promote ICAM; and
- reactions from the community, or growing awareness.

One or a combination of several triggering factors can influence decision makers to initiate the process of ICAM.

Political decisions and commitments by the relevant authorities are needed to initiate ICAM and start the activities to develop an ICAM proposal. Decision makers should act on the basis of information about triggering factors either already available or deducible from analogous situations, and on a broad professional and social consensus about the need for ICAM. The level on which decisions should be taken will depend on the scale of the geographic area and its significance in the national context (national, sub-national, regional, or local).

All the elements necessary for deciding to start ICAM have to be contained in a proposal prepared by the concerned parties (authorities, scientific communities, NGOs, individuals, etc.). Such a proposal refers only to the activities to be carried out in the preparatory ICAM phase before the final decision to proceed with ICAM is taken.

The proposal to decision-makers should contain the following:

- Analysis of the prerequisites of ICAM;
- General goals of ICAM;
- Tentative boundaries of the geographic area to be considered;
- Modalities of the horizontal and vertical links between institutions and organisations expected to participate in the preparatory phase;
- Financial means available for the completion of the preparatory phase; and
- Workplan and time table (activities, responsible institutions, time required)

Of particular importance is the definition of the role of the coordinating mechanism which will be responsible for guiding the ICAM process during the preparatory phase. At this stage of the process the main task of this coordinating mechanism is to bring together the various governmental and non-governmental institutions and organisations involved in ICAM in order to prevent conflicts among them, and to enable a rational use of financial and human resources needed for the implementation of ICAM.

BOX 12

The Coordination Mechanism for ICAM

The main purpose of the coordination mechanism for ICAM is to:

- (a) promote and strengthen interagency and inter-sectoral collaboration;
- (b) reduce interagency rivalry and conflicts;
- (c) minimize duplication of functions of line agencies;
- (d) provide a forum for conflict resolution among sectors, and to
- (e) monitor and evaluate the progress of ICAM projects and programmes.

Source: The World Bank. 1993. Nordwijk Guidelines for Integrated Coastal Zone Management. The World Bank, Washington D.C. U.S.A.

Preparations for the initiation of the ICAM process necessitate some prerequisites to be met. Of particular importance are the following ones:

- Political will and public (including NGOs and scientific institutions) awareness;
- Scientifically based knowledge of the coastal and marine ecosystems;
- Existence of global national strategies;
- Recognition of the value of coastal and marine resources and potential benefits from sustainable management;

- Management capability and adequate human resources;
- Financial support.

In the majority of cases, and particularly in developing countries, all the listed prerequisites will not exist in the moment of making decision on the introduction of ICAM. In other cases, some prerequisites will be only partially fulfilled. Regardless of such circumstances, the activity should not be given up, but a part of the programme in its initial phase should be aimed at meeting the prerequisites to the extent which is realistic.

The authorized political body takes the decision to launch the ICAM process, i.e. the relevant preparatory activities. That body can also decide that the conditions for launching have not matured, in which case it is advised to reconsider this decision after some period of time.

3.2.2 Preparatory phase of the planning stage

The purpose of this phase is to identify and support a proposal to decision-makers to establish continuous and integrated management of the coastal and marine area.

The first task to be performed within this phase is to prepare a *coastal profile*. Based on the existing secondary data, a coastal profile helps identify the coastal resources, activities, uses, habitats and protected areas, as well as major resource management issues, such as open access to coastal resources, multi-purpose use, development patterns, user conflicts and specific priorities for management in a coastal area. The existing data often have to be complemented with a questionnaire containing questions on all relevant aspects of development and environment of coastal areas. Questionnaires have to be filled out together by local and national experts.

The second task, to be performed using the coastal profile and inputs from various sectors and interest groups, is to prepare an *ICAM programme*, which is a *problem-oriented* document consisting of the following:

- Precise definition of the coastal area, i.e. the area boundaries (for example, in the case of areas covering the totality of a national coastline it is desirable to include the relevant drainage basins and the national maritime exclusive economic zone; in the case of smaller island states, the inclusion of the whole national territory is advantageous);
- Identification of the main problems of the area and their causes (sector by sector with emphasis on problems requiring cross- sectoral solutions);
- Proposal of the general goals and objectives of development and environmental protection; preparation of development outlooks and tentative strategies for their achievement; analysis of the social and economic implications of the strategies proposed;
- Identification of information gaps;
- Analysis of other planning programmes and project activities, with the assessment of their impacts on the coastal area and in relation to their relevance for ICAM activities;
- Proposal for the preparation of the Integrated Coastal Master Plan;
- Analysis of legal requirements posed by the proposal (e.g. a need for new legislation or for changes in existing legislation);
- Analysis of the financial requirements of the implementation of ICAM; and
- Proposal of institutional arrangements needed to support the coordination and implementation of ICAM.

BOX 13

Contents of the "Integrated Planning Study for the Island of Rhodes, Greece"

The Integrated Planning Study of the Island of Rhodes (produced by PAP-MAP) provides an example of the document to be prepared in the preparatory phase of ICAM. The final report of this study contains the following chapters:

- i) Introduction, in which the objectives, structure and methodological approach to the preparation of the Study are presented.
- ii) Development and environment: present situation and trends, in which the present development and environment processes are analyzed, and possible consequences pointed out should those processes continue at the same rate.
- iii) Development and environment: options for the future, in which the basic spatial strategy of the development of the island is developed.
- iv) Management action programme, which presents the list of actions to be performed in view of the implementation of the selected option of the spatial strategy of the island.
- v) Recommendations for immediate actions which present proposals of activities requiring urgent action. These proposals should not conflict with concepts of sustainable development. Financial and institutional requirements should also be given.

Coastal profile and ICAM programme can be prepared for several spatial levels in a country. These levels can vary from national (in the cases of a small country or an island country where the coastal area encompasses practically the whole country), sub-national regional (coastal region or a large island), and urban (area of a coastal city and its immediate hinterland), to the level of small coastal settlements such as fishing settlements or sites where they already exist or where there is certain planned development. Each spatial level determines the degree of detail into which issues have to be elaborated in individual documents. The basic rule says that the higher the spatial level the lower and less detailed the degree of dealing with various issues.

The above documents contain maps which present graphically the individual coastal issues. It is assumed that already in the initiation phase of ICAM analysis will be made of the existing graphic documentation, i.e. that themes and scales will be identified of the maps available with the relevant administrative departments in the area concerned. The existing maps represent not only the graphical basis for the preparation of the coastal profile and ICAM programme (as well as other documents at later phases of the ICAM process), but can also be an important source of information.

The scale of the maps to be used for the preparation of the coastal profile and ICAM programme is very important. It is determined by the scale of the maps available with the relevant departments. One has to adapt to the actual situation since these phases of ICAM do not envisage preparation of new maps. The scales can vary considerably, as given below:

- national level: 1 : 200,000
- sub-national regional level: 1 : 200,000 - 1 : 50,000
- urban level: 1 : 50,000 - 1 : 10,000
- site level: 1 : 10,000 - 1 : 1,000

In the preparatory phase, the training component is of great importance. Preparation of the local capacities for the implementation of the ICAM process is the key element of its success. Departing from the assumption that in most cases the knowledge on the methodology of ICAM implementation is rather limited, already in the beginning of this phase it is necessary to start with training activities, that can take several forms, such as:

- Traditional training courses planned as a combination of lectures on basic issues of ICAM and practical exercises, usually using as the case study the area for which the profile of programme will be prepared;
- On-the-job training: local and national experts are trained in course of the work on the given case; and
- Training through public participation and raising of public awareness of coastal issues.

The first two forms are typical of the "top-down", and the third of the "bottom-up" approaches to ICAM.

The ICAM programme, including the proposal of future activities, should be reviewed, and the decision on the ICAM process made. The decision-making body can decide to continue the planning phases of the process, or to stop the process. The decision to stop the process would assume that conditions do not exist for the continuation of the process, or that the proposed actions within the ICAM programme can be implemented immediately. In that case, these are just short-term measures, and the decision on the continuation of the process has to be reconsidered at a later time. The decision to continue ICAM has to be taken at an appropriate political level with sufficient authority to ensure long-term political and financial commitment to ICAM. This will ensure that the issues raised and proposals made in the documents resulting from the preparatory phase are implemented in the following stages of the process.

3.2.3 Analysis and forecasting

Following the preparatory stage, and once the decision to establish ICAM has been made, a far more detailed stage of analysis is to be carried out.

The purpose of this phase is to provide an analytical basis for the establishment of precise goals and objectives and definition of management strategies for sustainable development in the coastal area. However, this phase is strongly issue-oriented as the research is mostly aimed at the problems identified in the previous phase.

In this phase it is necessary:

- to carry out new surveys in order to identify selected issues within sectors of human and economic activities, natural system processes, and institutional arrangements;
 - to analyze the natural systems in the coastal and marine area;
 - to analyze the system of human and economic activities in the coastal and marine area;
 - to estimate (forecast) future demand for goods and services from coastal resources, and their capacity to fulfill these requirements;
 - to prepare alternative cross-sectoral scenarios, and to select the most effective one.
- (a) *Surveys on selected issues* in which new primary data are generated should only be carried out where information gaps have been identified. This activity refers to the updating of the existing data base, and to the increasing of scientific knowledge on coastal natural systems. This new information, and the information collected in the previous phase, is to be used for subsequent analyses.
- (b) *Analysis of natural systems* is aimed at identifying socio-economic impacts on natural systems resulting from the use of resources. It should include the following:
- Estimation of current rate of resource use based on economic and social patterns in the coastal area;

- Assessment of the impacts of resource use practices on the state and stock of natural resources;
 - Calculation of waste generated from economic and other urban activities;
 - Calculation of waste being discharged into natural systems, and particularly in coastal waters;
 - Calculation of waste generated in other regions and discharged in the natural systems of the planning area;
 - Assessment of possible effects of climate changes and other hazards on the state of the natural and socio-economic systems;
 - Generation of information on the impacts of socio-economic activities on natural ecosystems.
- (c) *Analysis of the system of human and economic activities* in coastal and marine areas is focused on the identification of their levels and spatial patterns. The following shall be analyzed:
- Demography (vital statistics, income levels, employment opportunities, population distribution, etc.);
 - Economy (industrial inventory, major inputs and outputs of industry, energy production and consumption, transportation structure, consumption patterns);
 - Social structure (migrations, living conditions, health impacts of environmental degradation, cultural patterns, perceptions on the environment and resource uses);
 - Spatial structure (land and sea uses and capability, settlement structure, urban pattern, infrastructure systems);
 - Institutional structure (legal system, administrative structure and capabilities, resource management procedures, etc.);
 - Exposure to risks (sea level rise, technological risks and hazards, etc.).
- (d) *Forecasting future demand on coastal resources* and their capacity to fulfill these requirements is based on the assessment of impacts of the planned activities in a coastal area. Forecasts should be based both on projections of existing trends and on forecasts of the activities not currently affecting, but expected to affect, the natural systems in the future.
- (e) The forecasts should be integrated in the form of alternative *cross-sectoral scenarios*, each of which refers to a different future development course (scenario method is explained in the Chapter 4.6). Using a number of criteria based on tentative goals and objectives approved in the preparatory phase, *the most appropriate scenario would be selected*.

3.2.4 Definition of goals and strategies

This is one of the most important phases of the whole ICAM process. Before proceeding further, decision-making bodies at the highest level have to approve the goals and strategies of environmentally sustainable development in the coastal area concerned. This phase consists of several steps:

- Refinement and adoption of goals and objectives;
- Preparation of alternative strategies; and
- Evaluation of and decision on the most suitable strategy.

Goals may be defined as *general development and environmental guidelines which should be followed in the course of the ICAM process*. The goals should be followed up to the moment when they are achieved or, perhaps, revised and amended. Public participation in goal formulation is essential in their realization. Since goals secure the strategic guidance of the process, it is important that they are presented clearly and explicitly, and that they are not contradictory.

Goals can be broken down into a number of compatible objectives. The objectives should be operational, in a quantitative form where possible, and should be short-term compared with the longer-term time horizon of the goals. Goals can be divided into three categories: global, area-specific and sectoral.

Global goals are those which refer to issues and problems of general importance for coastal areas, which are of a multi-sectoral nature, and which do not refer to specific geographic areas (for example, a goal is to ensure the sustainable use and development of the resources of coastal areas, without undermining their ecological integrity).

Area-specific goals are also of a multi-sectoral nature, but are defined with regard to the specific conditions prevailing in smaller geographic areas (regional-international, national, sub-national-regional and local). For example, a country with a relatively undeveloped coastline may set, as one of its goals, the development of new facilities by encouraging investment in tourist centres. Contrary to that, a country with a highly congested coastline may set a goal of restricting the expansion of tourist and recreation facilities to existing centres.

Sectoral goals refer to issues within a single development or environmental sector typical of coastal zones. These goals can be applicable at all geographic levels. It is a common case in coastal areas that relevant authorities tend to stimulate the development of a particular sector which is based on the use of the abundant natural resources such as tourism, fisheries, aquaculture, agriculture, etc., giving it priority over other sectors.

All goals must be complementary, and arranged in a hierarchy. The global goals provide the framework for defining the area-specific and sectoral ones, while the sectoral goals, if they are also area-specific, have to fit into the typical features of individual areas.

The next step in the implementation of this phase of the ICAM process is the development, on the basis of the goals and objectives defined by relevant government levels, of *coastal area management policies*.

The objective of ICAM is to avoid policy conflicts which often cause environmental problems in coastal areas. In other words, in this phase it is necessary to coordinate various aspects of individual sectorial policies (for example, among fisheries, tourism, land use, industry, etc.). The most important element of coastal area management policies is political commitment to see the policies translated into action.

When defining the policies, the goals, objectives and priorities must be clearly pointed out, and the framework that identifies financial, human, technical and institutional resources needed for their implementation must be outlined.

Policies should be carried out through the implementation of various management strategies.

Compared to policies, strategies are a succession of logical steps aimed at the realization of the goals and objectives which were set in a policy statement. In this phase of the ICAM process, sectoral and cross-sectoral general strategies are defined. These will, in turn, produce a range of options for reaching the goals and objectives.

BOX 14

Coastal Management Strategies

Strategies to implement coastal resources policy in relation to *individual economic sectors* include:

- Management of fishery resources;
- Management of recreation and tourism;
- Management of extraction of minerals, sand, gravel, oil and gas; and
- Management of marine transport.

In addition, strategies that cut *across sectors* are required, such as:

- Pollution control;
- Management of coastal land use and protection of significant landscapes and conservation of coastal ecosystems;
- Management of overall economic growth; and
- Management of governmental and private use of coastal resources.

Source: OECD. 1993. Coastal Zone Management: Integrated Policies. OECD, Paris, France.

The objective of the next step in this phase of the ICAM process is the integration of sectorial and cross-sectorial management strategies. This step is based on the existence of a high level of inter-dependence among these strategies and on the need for their implementation in a coordinated way. A typical integrated strategy should pay attention to the pattern of future activities in the area, and indicate the intended changes in the physical, economic, social and environmental life of the coastal area as a result of the implementation of desired policies.

In most cases alternative strategies could be generated. When strategies are evaluated and one is chosen for presentation to decision makers the strategy should include a definition of criteria (qualitative) and standards (quantitative). Criteria and standards would permit the use of coastal resources within limits designed to protect them from irreversible damage. However, the standards may change over time as public awareness of environmental quality increases. The criteria represent the factors which the decision makers and other interested groups consider relevant for the evaluation of usefulness and the later adoption of a strategy. The sustainability of coastal area development should provide the fundamental criteria for the selection of strategies.

The final output of this phase is a document which may be called "*Management Strategy*" or "*Strategic Plan*". It should not be too detailed, but consist of the major dimensions such as: future population growth, economic structure, social patterns, basic land and sea use, major infrastructure systems, environmentally sensitive areas, conservation requirements, priorities, institutional structure, legal and financial requirements, etc. This document is intended for the use by decision-makers with the aim of final acceptance of the coastal area management strategy which will serve as the basis for the preparation of the coastal management plan in the next phase of the ICAM process.

3.2.5 Integration of detailed plans

The document to be completed in this phase is the *Integrated Coastal Master Plan (ICMP)*. Depending on the size and economic structure of the country, ICMP might be prepared on a national basis, but more often it is prepared for a specific coastal region. It is a complex document which requires considerable institutional and financial resources. The objective of the ICMP is to create conditions for making operational decisions in the implementation phase of ICAM, relative to the realization of the concept of sustainable development of coastal areas.

By its nature, the ICMP is a document which offers a very wide perspective and which contains long-term solutions to the problems of coastal areas. ICMP specifies a course of action for interested persons, decision makers and professionals in the field in their performing of daily

management duties. However, uncertainty increases as the perspective of the plan widens and the time horizon lengthens, and the possibility increases of the operative decision-makers being forced to deviate from the plan. It is possible to overcome this problem by introducing flexibility into the planning process, so that the institutions entrusted with its implementation can respond, through monitoring and feedback, to changes in the planning context.

The principal task in this phase is a detailed elaboration of the selected cross-sectoral management strategy prepared in the previous stage. The ICMP should include the definition of physical requirements that the implementation of the integrated management strategy may generate in the ICAM area, and the preparation of the plan of action by which this strategy could be implemented. This should include detailed site-specific proposals for land and sea use based on detailed plans for prioritised areas, where sectoral policies and programmes of action related to the development and protection of the resources of the area are well integrated. Such a document should pay particular attention to the points given in Box 15.

BOX 15

Some of the Major Dimensions to be Taken into Consideration in ICMP:

- i) System of urban and rural centres (boundaries of built-up areas, main economic and social functions, distribution of population, service areas, social facilities);
- ii) Protected areas (natural areas, national parks, environmentally sensitive areas, marine habitats, cultural sites, historical and archeological sites);
- iii) Open spaces (protected natural areas, national parks, landscape reserves, coastal reserves);
- iv) Agricultural land (areas and sectors capable of expansion, permitted change from agriculture to other uses, protected agricultural land, irrigated land);
- v) Forestry (areas for wood production, grazing and recreational uses);
- vi) Mining (potentially exploitable areas which would not cause environmental damage);
- vii) Industrial areas (areas where industry may be permitted, expected expansion of existing industries, additions of new industries, restrictions on polluting industries);
- viii) Residential areas (major built-up areas, standards);
- ix) Tourism and recreational areas (centres and areas allocated for the development, areas of highly restricted development, accompanying recreational areas);
- x) Sea uses (transport facilities, shipping lanes, fishing areas, mariculture, recreation, marine protection);
- xi) Transport corridors and areas (road network: accessibility and hierarchy of network; railway network: inter- and intra-urban network, interrelationship with the proposed road network; airports: international, domestic, charter, agricultural, cargo; telecommunications: location of aeriels, cable network);
- xii) Other infrastructure (electricity network: location of power stations and sources of fuel, main transmission corridors, transformation stations, non-conventional sources of energy; water supply: reservoirs, pipes; sewerage system; oil refineries: storage and pipelines; irrigation system).

In addition, the ICMP should outline the basic administrative framework which the plan requires for its implementation, and which is already broadly defined within the ICAM framework. The ICMP should include those aspects of the proposed policies which can be implemented by existing laws and regulations, as well as those requiring new legislation, and the agencies which will play a key part in the process. The ICMP will also meet the need to:

- establish the procedures envisaged for the approval and the periodic revision of the plan;

- identify the authorities which will adopt the planning policies and introduce the planning controls into their operations;
- define expenditure priorities and the technical personnel required to implement the plan;
- ascertain how the required "development control" system will operate in principle and the extent to which this system exists (establishment of EIA procedure, cost-benefit analysis, etc.);
- ascertain the form of instruments proposed, such as building permits, planning permissions, industrial licenses, zoning regulations, development briefs, design directives, etc.;
- identify the legal basis and, if possible, the administrative body which will exercise these controls;
- ascertain the powers available to public agencies or corporations for compulsory land acquisition, land banking, land lease, and the practice followed in land valuation in cases of public land acquisition and restriction of private development rights for plan implementation purposes;
- ascertain the financial institutions which are expected to become actively involved in mobilizing funds for projects, the local budgetary process, the revenue and expenditure structures, and, possibly, avenues for private-public joint ventures, and indicate the likely impact of the implementation measures on the existing structure of financial institutions and processes;
- specify the instruments to be used in the plan implementation (see section 3.3).

3.2.6 Implementation of plans

The proposals defined in the Integrated Coastal Master Plan should be formally adopted at an appropriate governmental level. An adopted plan should have legal status, and the solutions and policies should be implemented in a well coordinated way. In coastal areas, a coordinating body takes the leading role in the plan implementation (tasks of this body are presented in greater detail in the section 3.3).

The plan implementation is most efficient if implementation phases are defined. This phasing is essentially a break-down of the ICMP proposals which usually cover periods of up to 20 years into short, medium and long term targets to arrive at a series of operational programmes fitting into identifiable 3-5 year periods over which detailed project planning, resource management and forward budgeting can be prepared and executed. In this way, the overall plan for the whole planning area, becomes implementable through specific activities in priority locations.

The first stage should be sufficiently self-contained to form a clear scenario of viable and specific actions but conceptually well integrated into the overall ICAM process and logically connected with the second stage. The same relationship should be maintained between all the stages of implementation. Phasing should be designed to translate the long-term strategy into specific actions and locations, and to be carried out within a rolling programme where five-year objectives and annual targets follow on continuously.

To implement the process, it should be broken into smaller, manageable tasks or investment projects within the resources and adaptive ability of the administrative system, the budgeting process and the public at large. This offers much more scope for flexibility and adaptability as smaller components of the proposed plan can be manipulated much more easily than the overall strategy.

An important advantage of phasing is the minimization of risk and of uncertainty in the planning process. Phasing reduces the element of uncertainty in the implementation process by bringing long-range goals into closer perspective and limiting the range of time over which specific planning objectives are expected to be reached.

Of great importance in this phase is the application of instruments to determine the environmental effects of the plans and projects defined by ICMP. It is particularly recommended that Environmental Impact Assessment (EIA) and Cost-Benefit Analysis (CBA) be included in the process of ICMP implementation.

3.2.7 Monitoring and evaluation

Monitoring and evaluation of ICAM implementation are both broadly concerned with the assessment of the performance of the ICAM policies and the results achieved by ICAM over the years, relative to the goals and objectives of the ICAM process.

The monitoring or "watchdog" part of the ICAM process must establish a regular flow of information on the decisions, actions and investments involved in the implementation of the ICAM. Evaluation uses the information generated by continuous monitoring to analyze:

- the effectiveness of ICAM decisions,
- the efficiency of the investments undertaken,
- whether the benefits of the ICAM process have been equitably distributed among the various social groups of the community; and the impacts of ICAM actions on the environment.

Monitoring and evaluation procedures are crucial to the ICAM process as they must systematically feed information back into the process. This will allow for continuous revision and up-dating of goals and objectives in the light of actual performance, effectively securing continuity and integration in the ICAM process. The implementation process should be under constant review to allow for necessary adjustments to the policies in the light of changing conditions. There is a limit to the flexibility of any process, and there is always a stage in the implementation process after which further changes are difficult to accommodate without high costs. It is, therefore, crucial that continuous evaluation is made of the costs and benefits likely to derive from adjustments to planning and implementation objectives.

3.3 Institutional, legal and financial arrangements for ICAM

Given the highly complex economic structure of coastal areas and their unique and often fragile environment, special arrangements are needed for their efficient management. These arrangements consist of an administrative structure, a legal framework, a financing mechanism and policy instruments for implementation.

3.3.1 Institutional arrangements

One of the most frequent constraints on achieving ICAM is the lack of appropriate institutional arrangements. Due to its complex nature, ICAM requires a high level of integration within and between institutional structures. A high level of horizontal integration is particularly necessary between sectoral institutions at the planning stage and a high level of vertical integration is necessary within institutions at the implementation stage.

Many of the institutions needed for ICAM may well exist. The linkages between them may have to be created or strengthened. Where no such institutions exist, a new institutional arrangement may need to be created.

Existing institutional structures may be composed of government and local authority representatives. The successful achievement of ICAM will require the active participation of stakeholders in the public and the private sector in many of the institutional arrangements. This generates the need for building human resource capacity for ICAM both in the fields of coastal and marine sciences and in the fields of environmental management and conflict resolution.

Institutions for ICAM have three roles:

- An executive role, for decision making;
- A judicial role, for enacting regulations and directives, standards and procedure enforcement and arbitration;
- A market role, allocating funds, offering incentives or subsidies.

Institutional arrangements are needed at three different levels for taking specific responsibility for coastal arrangements:

- National,
- Regional (sub-national),
- Coastal area (local).

National level administration should be concerned with development and implementation of broad coastal management policy; this would include preparation of a *Coastal Area Management Act*, a *Coastal Area Management Strategy*, and designation of a *lead agency* for coastal management at the national level, e.g. Environment Ministry or Department of Public Works or Ministry of Local Government. The role of the lead agency is to be a facilitator for bringing together various agencies involved in ICAM and stimulating a dialogue between them. The choice of a lead agency will vary from country to country depending on the allocation of responsibilities in each country. At the national level environmental and conservation standards need also be laid down for coastal areas e.g. coastal water quality. There needs to be an interdepartmental (interministerial) committee for coastal management consisting of the major ministries operating in the coastal areas: environment, tourism, economic development, industry, public works, transport, forestry and agriculture. A degree of indicative national planning is needed to inform regional and local authorities of the intentions of national development policies.

At the *regional level*, depending on the authority of regional governments, more detailed but integrated planning and management are required within the responsibilities of the regional authorities. Such a process should ensure the consistency between the activities of local governments to reduce the danger of overloading the coast. This should also cover areas outside local governments and in some cases where conflicts with national authorities may occur, e.g. defense.

Detailed planning, development and implementation takes place at the *local level*. However, distinction should be made here between areas where one local government authority can effectively manage the coastal zone and those areas where several local governments need to co-operate closely to plan and implement policy. This will depend on the nature of the coastal area both along the horizontal axis but more importantly on the perpendicular axis to encompass all the major activities having an impact on the coast.

To cover all land resources and coastal waters all authorities involved in the operation, exploitation, conservation and maintenance in these resources should integrate their activities within a coordinating mechanism, for example a Coastal Area Management Committee. Such a committee might be established on a voluntary or on a statutory basis. It should meet regularly and could have the following functions in guiding the ICAM process: review major development

proposals, take decisions on these proposals, define the functions of the participating bodies in the decision making process and ensures public involvement, and assist in revenue raising and allocation of funds.

BOX 16

Possible Framework for ICAM of Izmir Bay (Turkey)

A possible model for ICAM implementation is Turkey's proposed Izmir Bay management committee which would include a secretariat and specialist working groups. This could be structured so that the committee reports ultimately to the Minister of the Environment. The Prime Minister's Department of Environment would have a representative in the management committee together with the representatives of other relevant government departments (such as Fisheries, State Planning, and Transport). Also included in the management committee could be one representative of each the Izmir Metropolitan Municipality, the Governor's Office, and UNEP-PAP.

The management committee would establish and monitor the achievement of the management goals, policies and strategy established for the bay. The committee would be served by a secretariat that would have the role of reporting to the management committee on the work and recommendations of the specialist working groups, as well as reporting on the performance and continued applicability of policies and controls. Several working groups could cover matters such as water quality, resource management planning, environmental impact assessment, and review of project proposals, economic analysis/project appraisal, and information and data systems.

A core staff could be assigned to each of these working groups and have the ability to draw on the expertise of outside specialists in institutions such as universities and research centres, as necessary. In addition, the working groups should involve and take account of inputs from local authorities to better coordinate land, water resources and coastal planning. In carrying out their work, the working groups might consider the use of a wide range of instruments, such as taxes, incentives, regulations, penalties, and performance standards, to achieve desired management goals.

Source: OECD. 1993. Coastal Zone Management: Selected Case Studies. OECD, Paris, France.

Coastal managers at the Coastal Area Management Committee level would have to ensure the creation and the effective operation of such committees. They would have to be fully acquainted with national and regional coastal management policies and operations and use them for the operation of their committees. They would have to ensure that all the above functions of the coastal area management committee are carried out according to specific guidelines and sequence. Whatever the institutional arrangements, a manager will be needed to fulfill a central role in setting-up and running the committee and its various groups.

3.3.2 Legal arrangements

Legal arrangements are needed at different levels to make ICAM possible. Many countries enacted a Coastal Area Management Act which sets out various institutional arrangements, property rights, user rights, access to judicial process, right of the public to intervene in the management process, and even financing mechanism for coastal planning. At the same time many other acts and regulations are in force in coastal areas dealing with a variety of activities: shipping, fisheries, general environmental, conservation, transport and local government laws, etc. Some of these laws are often dated and they can be contradictory, particularly in their interpretation. Often there is little guidance in these laws as to their order of precedence.

For coastal managers one of the main tasks is to ensure an interpretation of the various laws and regulations on coastal areas and activities that will facilitate the use of coastal resources without infringing environmental and conservation legislation. This should be achieved through negotiations in the coastal management committee. Should this fail recourse might have to be taken via the judicial process or other arbitration procedure.

Coastal managers might also have to take the initiative to demonstrate the need for specific and special environmental standards for certain coastal regions where circumstances would require them. Coastal managers, for example, can assist local authorities in devising regulations on such matters as property rights in beach areas, access to the coastal strip, or minimum distance of buildings from the shore, when these are not specified in national legislation.

3.3.3 Financing mechanism

Three types of financing requirements are generally essential for effective ICAM: financing of the administrative structure, the planning, the information system and the project review mechanism; financing the infrastructure and pollution control expenditures; and financing of conservation measures.

Depending on the objective of expenditures the financing mechanism will be different, so that:

- to finance the administrative structure and related expenditures the money will have to come from the budgets of national, regional and local authorities;
- to finance infrastructure and pollution control, moneys can be largely generated from user charges and costs can be partially passed on to industry (user charges and similar financing instruments are described in Chapter 4 under implementation instruments);
- financing of conservation of reserved areas can be undertaken partly from private voluntary financing and partly from visitors' fees, etc..

Coastal managers' tasks in financing are different according to the type of financing involved:

- Concerning funding from the various budgets, they should try to ensure that funding requirements be incorporated into the respective legislation; otherwise, the agency most interested in the proper management of the coast might have to provide the financing;
- Concerning user charges and similar financing instruments, the manager will have to rely on them for the efficient implementation of measures as well as for financing; consequently he/she will be advocating and using them as part of the implementation process in conjunction with local authorities and other agencies. Part of his task will be to secure these funds for the installation of infrastructure and other services and minimize the amounts that are paid into general revenue and lost to coastal management;
- Raising funds for conservation to set land aside in perpetuity is now a fairly common practice; private funds are often raised by interested environmental groups and their efforts are supported in various ways by coastal managers: for example private fund raisers usually need the assistance of the managers to establish under what conditions their efforts would be approved by the authorities; sometimes these funds are raised as matching funds (partly private and partly public). Conservation could be financed and maintained from visitors fees in the cases of unique sites or animal reservations, etc.

4. TOOLS AND TECHNIQUES FOR ICAM

The nature of coastal development, the environmental interactions of sectoral activities and the complex management requirements imposed on decision makers and professionals involved in ICAM require the employment of numerous specific tools and techniques. Most of them are based on methodologies which can be handled by national expertise available in many developing countries. The following broad classes of tools and techniques are recommended in the application of ICAM (based on the experience of MAP/PAP in the Mediterranean):

- Data management;
- Evaluation and assessment techniques (environmental assessment, risk assessment, economic evaluation, prospective studies); and
- Instruments for implementation: regulatory and economic, bargaining, negotiations and voluntary agreements, conflict resolution techniques.

4.1 Data management

Data and information bases are essential tools of ICAM, helping to reduce the high level of uncertainty, thus providing decision makers with ways of identifying relevant coastal issues, indicating expected impacts of alternative actions, and providing information on present and expected costs and benefits.

Database for ICAM should be functional, and selected with regard to its application for the execution of defined tasks, such as:

- Indication of areas or variables likely to be under pressure from future urban and coastal development;
- Selection of sites most appropriate for essential public services which do not cause environmental degradation, e.g. sanitary landfills;
- Identification of resources of high sensitivity to the impacts of oil spills, for protection policies;
- Identification of priorities for nature conservation where sensitive ecological resources are in areas subject to upstream or up- shore pollution;
- Planning of tourism development in relation to the carrying capacity of coastal resources;
- Selection of alternative development scenarios or projects;
- Identification of appropriate policy instruments;
- Definition of appropriate financing mechanisms;

- Monitoring of the impacts of changes in a watershed on water quality, water flows and on ecological habitats in estuarine regions.

For each of the above applications, and for many other issues relevant to integrated coastal area management, the database user must identify both the data input required and the way in which it can be manipulated to achieve the application required. In many cases it will be a man-machine interface, where part of the operations are carried out manually before input, part by computerized processing and part may be manual following output, where additional expert evaluation is needed. A computerized database for the coast is not an end in itself (unless the purpose is to produce an atlas) but an interactive tool which can contribute to management decisions.

BOX 17

A suggested Database for ICAM

- (a) resource inventory covering quantity and quality of resources:
 - land area
 - built-up area
 - agricultural land
 - land set aside for conservation
 - land set aside for special purposes
 - forests
 - water resources
 - surface waters
 - ground water
 - coastal waters
 - marine resources
 - wild life resources
- (b) economic inventory
 - industry
 - agriculture
 - tourism
 - fishing and aquaculture
 - forestry
 - transport
 - energy
- (c) infrastructure
 - roads
 - railways
 - air
 - water supply
 - sewage treatment
- (d) pollution discharge inventory
 - air
 - water
 - waste

The most common uses of a database in ICAM are:

- identification of the key indicators of existing conditions to the present state of the coastal environment;
- identification of coastal resources under stress or at risk, and their level of vulnerability or risk of degradation;
- forecasting the possible impacts of alternative development trends on sensitive resources;

- identification of areas of opportunity, using site suitability and exclusion criteria;
- simulation and testing of alternative options;
- monitoring and feedback;
- exploration of available information and alternative scenarios through interaction tool with query capability.

An important element of data management for ICAM is bringing together the data on physical/natural resources, and the economic information (such as economic benefits of the development, the economic cost of environmental damage caused by the development, costs of measures to avoid damage, and the benefits if damage is avoided or reduced). The integration of the physical and economic data is one of the most complex tasks in data management for ICAM.

Within the context of ICAM, one of the emerging data management tools is the Geographic Information System (GIS). GIS is a specialized form of database system, distinguished by its ability to handle geographically referenced data, which can be displayed as map images, and which is capable of integrating environmental, social and economic data into one system. Geographically referenced data have the following basic characteristics:

- a variable to which attributes can be attached;
- its spatial location in two or three dimensions;
- its value at any point in time.

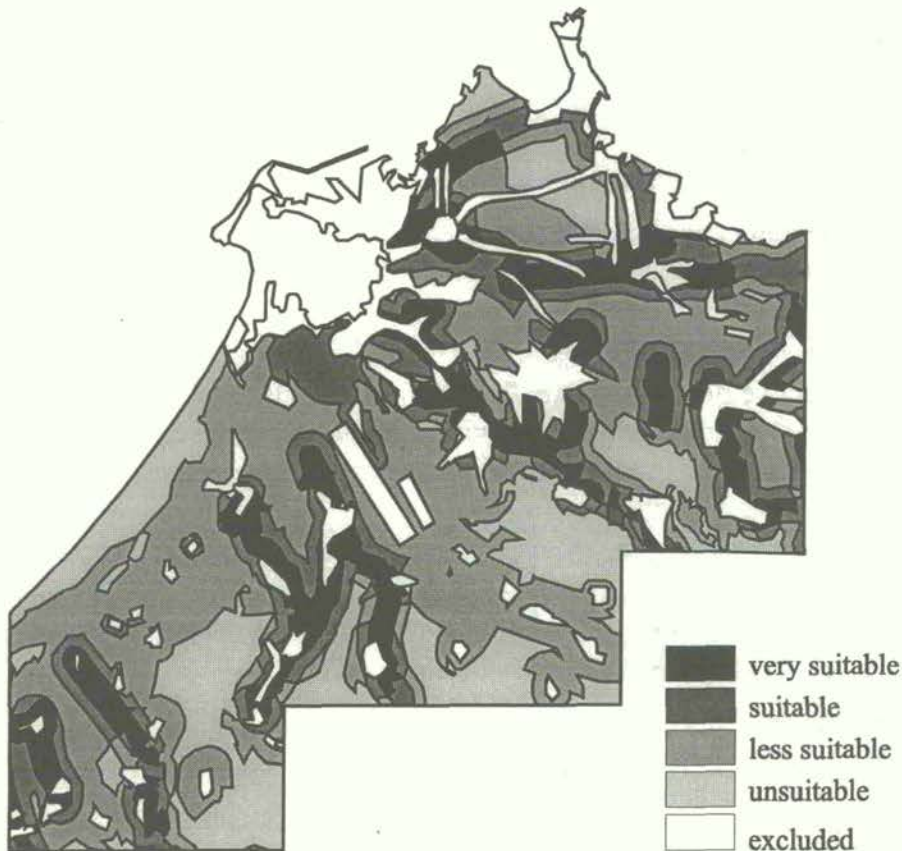

Figure 2. An example of application of GIS in the ICAM process: Suitability model for urban growth in Lattakia province - Syria

A simple use of GIS is storage and retrieval of geographic information, but it has the capability of contributing more useful analytical tools to the decision-maker. Data can be analyzed using spatial models which check the value of a variable in relation to its spatial characteristics, e.g. distance between variables, occurrence of different variables at the same location and the connectivity between variables. Developments in dynamic GIS are now adding further capabilities for the spatial analysis of changes over time, capable of indicating the impacts of small scale accumulative developments dispersed over a large area. Examples already include the analysis of changes in surface water flows in a watershed, using 3-dimensional digital terrain analysis.

GIS can also provide the decision maker with a query capability. Any issue may be investigated in an exploratory fashion to provide answers to *ad hoc* spatial problems. It is therefore a plan-making and on-going management tool and is already well-established in many systems of integrated resource information management.

Experience shows that, with initial training and a minor investment in software and hardware, it is possible to introduce and efficiently use GIS as a decision-making tool in any mid-size town/community of the Mediterranean developing countries.

Developments in remote sensing, particularly with the aid of satellite imagery, are now making data available for every country, for inaccessible locations where data were previously difficult to collect, for time series at repeated, regular, known intervals, easily updated, and at a high level of resolution. But technological advance is not going to solve all data collection problems for coastal management. Even after utilizing all the data that can be obtained through imagery, much will be needed from field survey. The only guideline for field survey which can be offered is that it should be reduced to the minimum necessary for the defined functions of the database system.

4.2 Evaluation and Assessment Techniques

The data collected and appropriately presented would in turn allow physical, environmental, economic and social evaluation both sectorally and in an integrated manner.

4.2.1 Environmental assessment

The specific objective of environmental assessment (EA) is to provide decision makers with information allowing them to introduce environmental-protection considerations early in the decision making process leading to the approval, modification or rejection of the project, activity or plan.

During the past 20 years a number of tools of EA have been developed and some of them successfully implemented: Environmental Impact Assessment (EIA), Carrying Capacity Assessment (CCA), Studies of Impacts of Expected Climate Change (Climate Impact Studies - CIS), and Rapid Assessment of Coastal Environment (RACE).

Most of these studies can be undertaken in considerable detail and with high degree of sophistication, but can also be applied in reduced and simple forms to suit the requirements of developing countries and small coastal communities.

Environmental Impact Assessment (EIA) is now a widely accepted tool. EIA is a process analyzing the positive and negative effects on environment of a proposed project or activity. The process consists of identifying, predicting, interpreting and communicating the relevant potential impacts. In the Mediterranean region the application of EIA is mandatory for major projects which can have considerable environmental impacts. The preparation of EIA varies however considerably from country to country and at present there is no agreement on a global or regional

(Mediterranean) level on procedures which may lead to comparable results. The complex EIA procedures used in some developed countries could be difficult to apply in developing countries due to the extensive data requirements and institutional and technical requirements needed for their implementation, the considerable time involved and the consequential costs in their preparation.

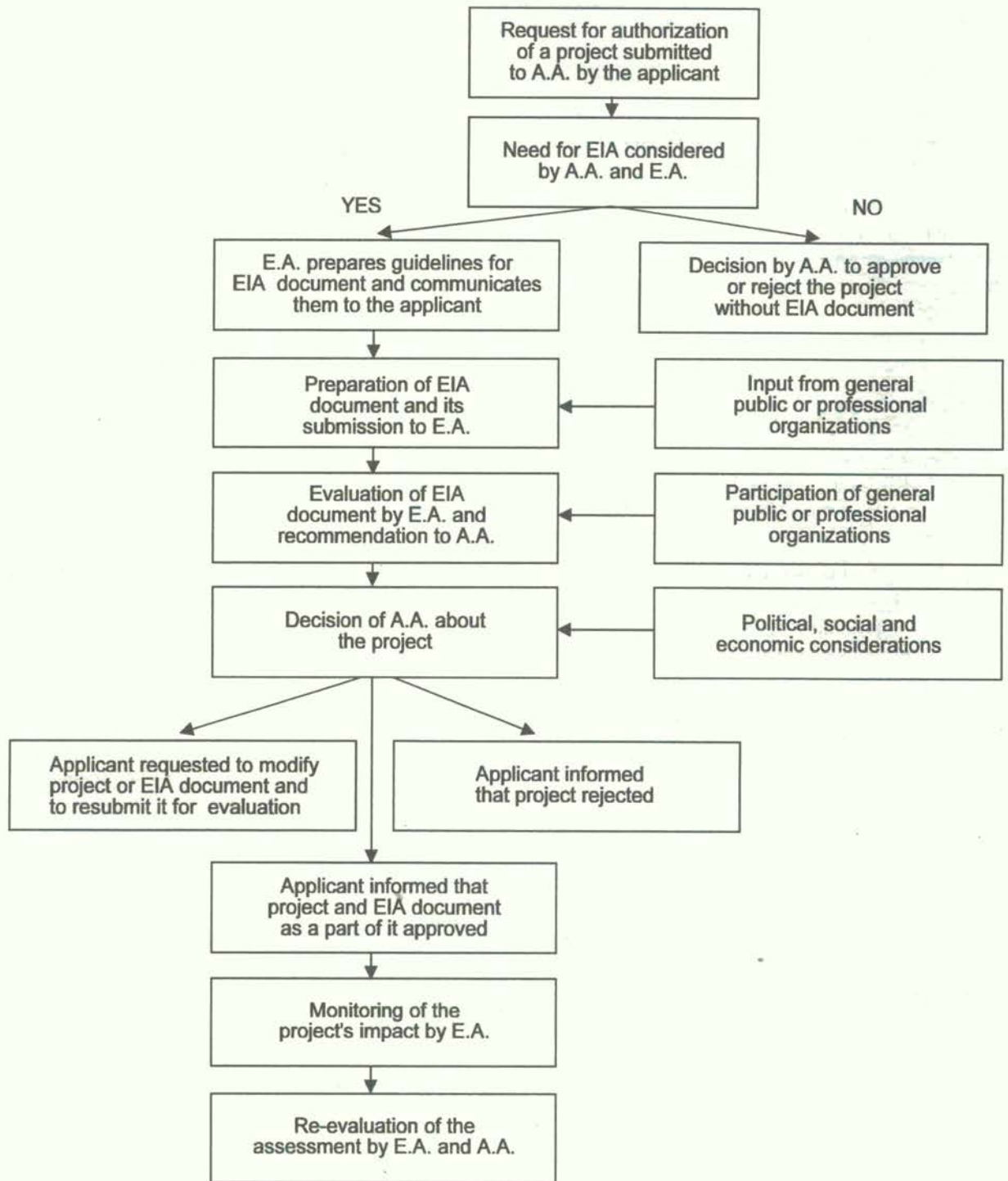

A.A. = Authorizing Authority
E.A. = Environmental Authority

Figure 3. Simplified Flow Chart for the Eia Procedure

Source: UNEP. 1990. An Approach to Environmental Impact Assessment for Projects Affecting the Coastal and Marine Environment

Environmental Assessment Studies are a special type of EIA used for assessing large plans and programmes incorporating many different projects or activities. For such cases complex environmental assessment studies need to be made which include analysis of the state and capacity of the recipient environment, evaluation of the individual impacts of major projects and their interrelations as well as the cumulative effects on the environment and resources.

BOX 18

Carrying Capacity Assessment Study for the Island of Rhodes

The object of research was a part of a large island, the overall surface area of which is 1,398 sq.km, with the population of 100,686 inhabitants (in 1991). The central-eastern part of the island, covered by the CCA study, has a surface area of 400 sq.km and 18,503 inhabitants (in 1991).

Characteristic of the island of Rhodes is a very high influence of tourism - over 40% of the active population is employed in tourism, catering and transports. Of the remaining part, 14% belong to agriculture, commerce and public sector each, 9% to building, and only 8% to industry and mining. There is a pronounced concentration of population and economic activities in the northern part of the island, around the capital, the city of Rhodes, with a tendency of spreading southwards. The entire procedure has been harmonized with the concept of CCA developed by PAP/RAC, which represents a calculation of several components of the CCA, and regards the lowest threshold.

As the first activity, the tourism profile of the island of Rhodes was analyzed, with special reference to the trend of building accommodation capacities and oscillations in the number of tourists and overnight stays. The analysis followed of the role and participation of tourism in the economy of Rhodes, including the population structure, employment and income by sectors and by geographic entities of the island (north-eastern, northern, central-eastern, western, and southern zones). Finally, environmental effects of the intensive tourism development were analyzed from spatially-ecological, economic and socio-cultural aspects.

The analysis took into consideration the highly complex problems of tourism development in Rhodes as a whole, and in its individual regions. One principal and one secondary zone of saturation were identified as most prominent. The principal zone of saturation covers the area around the city of Rhodes and spreads towards the settlement of Kremasti in the west, and along the eastern coast towards the Faliraki bay in the south. The secondary zone of saturation regards the town of Lindos and its immediate surroundings on the eastern coast.

The coastal strip in the eastern part of the island, from Lindos to the Plimiri bay, has been designated as a spare zone for future development, while for the entire western coast from Kremasti to the southmost point with the Prassonission peninsula strict protection has been envisaged. This is dictated by the geographical conditions (steeper coast) and environmental features. The protection should also cover the inland; as for the western coast, for the inland of the island, almost exclusively one-day visits have been envisaged, with a very small number of accommodation units of family type.

The possibilities of tourism development in the island were observed through a number of scenarios, paying a special attention to the instruments currently in force which define the land-use planning. This refers to the legal framework of the physical planning, detailed plans and regulations on the growth of tourism.

Only then was the carrying capacity assessment started for the central-eastern part of the island of Rhodes. This was performed through an analysis of the place of that area within the tourism development of the whole island, an analysis of the land use in that part of the island, and through the principal tourism development models. A detailed analysis was performed of the resource basis of the central-eastern part of the island, a development programme was created with a spatial distribution of tourism capacities by tourist zones, and finally, carrying capacity was calculated.

The maximum carrying capacity in the peak period of the projected year 2010 is 30,000 tourists. The value is much below the physical carrying capacity, which in the case of the beach area of the central-eastern zone of Rhodes amounts to 73,393 beach users. The projected value is also smaller than the ecological carrying capacity which was calculated at 57,000 visitors in peak periods.

Carrying Capacity Assessment (CCA). Carrying capacity can be best defined as the maximum load of activity or maximum number of users which can be sustained by a natural or man-made resource or system without endangering the character of that resource. By defining the carrying capacity for a certain activity it is possible to establish the framework for development and management of the areas under consideration. A practical example of such procedure for tourism activities is given in Box No. 18. Such application of CCA leads to the identification of the maximum number of users which can be absorbed at any time by the receiving area without disturbing the physical, economic and socio-cultural environment.

Studies of Impacts of Expected Climate Change (Climate impact studies - CIS). CIS can be used for long-term and large-scale coastal plans as part of ICAM. Inventories of endangered areas need to be prepared by national authorities while impact studies for each area would be carried out by the local authorities. The main elements of CIS include: planning and management assumptions, a study of the natural systems to be affected, identification and assessment of impacts and mitigation options. These possible options include adaptation in place, retreat and temporary solutions. The nature of response to expected impacts can be technical (i.e. to keep the sea back), natural (to replace lost or damaged resources), or non-structural (modification of the human use of coastal area or resources). No major project in coastal areas should be approved without taking into account the results of the relevant CIS.

Rapid Assessment of Coastal Communities (RACE) is a technique originating from agricultural studies, but applied to a coastal area it enables a rapid identification of major issues and problems. The RACE is a set of techniques and instruments used as a complement to ICAM. It uses only the existing secondary data. Direct contact with major users of coastal areas is an essential component of the RACE, which makes it appropriate only for smaller coastal communities and settlements. The RACE enables a faster implementation of individual phases of the ICAM process than in the case of traditional planning techniques. Out of 7 phases of the ICAM process, the RACE can be used in 3 important ones: initiation; preparatory phase; and monitoring and evaluation.

4.2.2 Risk assessment and management

One of the consequences of the intensive development of coastal areas and of the high population growth is that the probability of various risks is increasing, and ever larger numbers of people are exposed to them. The general awareness of exposures to natural risks (e.g. hurricanes) and technical risks (e.g. tanker accidents) is increasing but in many cases the relevant knowledge is incomplete, non-structured and not built into management policies and contingency measures.

In order to mitigate or prevent possible negative, and sometimes environmentally catastrophic consequences of such hazards, risk management techniques should be part of ICAM. However, risk management can prepare only for probabilities of risks occurring and can only broadly estimate their consequences. Three steps can be distinguished in the risk management procedure:

- Identification of major hazards;
- Assessment of the potential of individual hazards; and
- Formulation of a plan that integrates the various management approaches to risks.

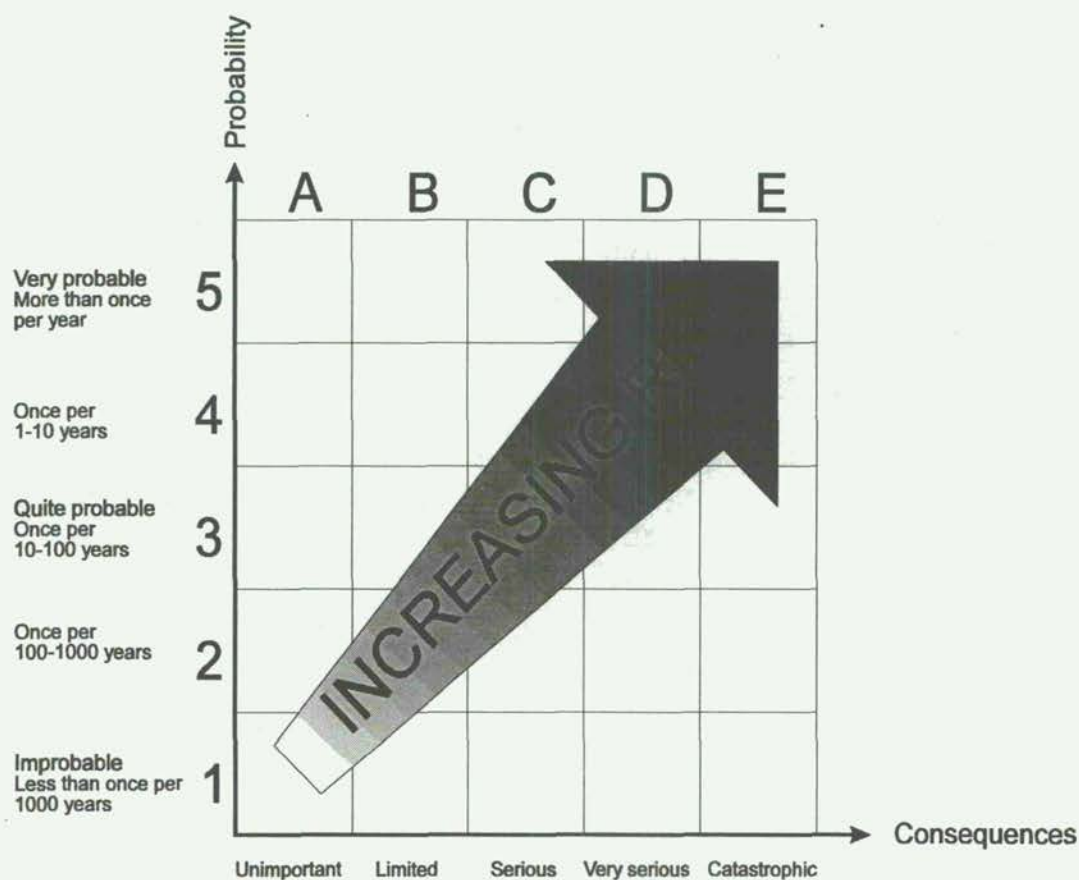

Figure 4. Risk Matrix

Source: UNEP IE/PAC. 1992. Technical Report No 12: Hazard Identification and Evaluation in a Local Community. UNEP IE/PAC, Paris, France.

Earthquakes are one of the major coastal risks in the whole Mediterranean basin. For risks such as earthquakes a national plan is needed. The general approach to seismic risk management is explained in Annex VI to this document.

Mitigation of risks from hazards due to industrial, energy, transport and other activities is based on a multidisciplinary approach which takes into account all types of hazards existing in a specific coastal area. A specific method for dealing with industrial risks, APELL (Awareness and Preparedness for Emergency at Local Level), has been developed by UNEP-IE/PAC. Figure 4 presents a risk matrix used by APELL. Within ICAM the main responsibilities for carrying out the three steps in risk management specified above lie at the subnational and local level. The national authorities should be responsible for overall coordination, institutional and legislative aspects.

Risk from oil and other toxic spills due to ship accidents is a significant coastal hazard. The relevant management actions should be organized at the national level and all coastal authorities concerned should be included. The contingency plans for response to accidental marine pollution deal with environmental, administrative, operational, logistic and technical issues. The main elements of the contingency plan are coverage, spill risk assessment, behaviour and fate of spilled products, organisation of response activities and spill response.

4.2.3 Economic evaluation techniques

Apart from physical evaluations, such as measurement of carrying capacity, environmental impact assessment, and risk analysis, economic evaluations should also be carried out to ensure

economic efficiency in coastal management. Neither carrying capacity assessment nor environmental impact assessment can provide economic information and therefore they are usually not sufficient for the economic partners in coastal management, e.g. industry, tourism and land developers to conduct negotiations. Only the combined results of economic and environmental assessments can provide acceptable options. This section proposes the use of the accepted economic evaluation techniques such as cost/benefit analysis and least-cost analysis for ICAM.

4.2.3.1 Cost/benefit analysis

Many outputs of coastal activities are channelled through the markets (tourist expenditures, industrial outputs, commercial fishery products). However, environmental benefits/damages (clean water and air, conservation of nature areas, etc.) are seldom traded in the markets. Furthermore, even market traded activities are evaluated only in financial and not in economic terms; and most activities and environmental protection require substantial expenditures that will produce benefits over a long period in the future. To provide a common denominator for these various activities, expenditures, costs, and gains require a comprehensive, analytic framework such as cost/benefit analysis (CBA).

BOX 19		
<u>Discounted Benefits of Restoration of Izmir Bay (1990-2025)</u>		
(million US\$, 1990 prices)		
ECONOMIC (OUTPUT) BENEFITS	Conservative scenario	Progressive scenario
1. Tourism	3412	8034
2. Fishing	133	133
3. Salt Production	843	1372
4. Underground Water	70	92
5. Corrosion	25	92
6. Recreation		
Bay	203	425
Bird Sanctuary	22	22
HEALTH BENEFITS		
1. Water Use	45	45
2. Dredging	20	45
TOTAL (Economic+Health)	4773	10191

Source: UNEP. 1993. Costs and benefits of Measures for the Reduction of Degradation of the Environment from Land-Based Sources of Pollution in Coastal Areas. MAP Technical Report Series No.72. UNEP, Athens.

(a) Type of projects to be evaluated

All major infrastructure projects and other governmental expenditures need to be assessed for their economic efficiency, taking into account their environmental benefits and costs, including the expenditures needed to protect the environment. In coastal areas these include water supply, sewerage collection and treatment, road construction, energy supply facilities, harbour works, coastal protection construction, ship construction facilities, governmental building projects for offices and production facilities, defense installations, and waste treatment facilities.

Private investment projects also need to be evaluated, particularly when they are subsidized by the government. All private projects have environmental impacts which require pollution control or conservation measures either by the entrepreneur or by the government. These projects should not go ahead unless they are economically justifiable without direct or indirect "environmental/conservation" subsidies and produce no significant environmental impacts. The subsidies often take the form of taxation allowances, cheap land for tourism or cheap government loans for various types of development, governmental expenditures to minimize their environmental impacts or straight-out cash subsidies.

(b) Practical implementation of the cost/benefit approach

In CBA a number of steps have to be carried out in a well-defined sequence. These should include:

- i) selection of the appropriate time frame for analysis; this should be for the life time of the project;
- ii) identification and allocation of all costs and benefits;
- iii) selection of the appropriate discount rate and discounting of all costs and benefits;
- iv) presentation of the results either as benefit-cost ratios or as internal rate of return;
- v) evaluation of results and making decisions.

(c) Limitations of the CBA evaluation

Although CBA is now widely used in governmental decision making it has so far found limited application in the field of environment. The reasons for this are difficulty in quantifying and valuing environmental damages and benefits and the uncertainty associated with long term environmental impacts.

In spite of these qualifications it is recommended that coastal managers should make extensive use of CBA as one of the tools of evaluation. The method properly applied offers a framework for a systematic assessment of individual projects. The requirements for a listing of all costs and benefits necessitate the cooperation of various agencies (development, environment and economic). Even if not all costs and benefits can be quantified and valued, better decisions can be facilitated in many cases.

4.2.3.2 Least-cost analysis

Under certain circumstances it is possible to reach decision on investments on the basis of the differentials in their expenditures. Such is the case when the differences in the potential benefits, produced by alternative investments, are so small that they can be ignored. For example the coast could be equally well-protected against storm damage by sea walls or by metal barricades in the sea. The difference can be found in the cost and in the visual impact of the type of construction.

In these cases it is sufficient to discount the cost streams to put them on a comparable basis. The applicability of this approach is limited but nevertheless useful under specific circumstances. Until now it has been widely used and is strongly recommended whenever cost-benefit analysis can not be carried out.

4.2.4 Prospective studies: development-environment scenarios

Understanding of the interaction between the environment and foreseeable future development is an important prerequisite for ICAM. Prospective studies exploring future options

are the tool for achieving such understanding. The basis for prospective studies is a systemic approach. It provides authorities, planners and managers with the opportunity of setting their development strategies within a context that assures the protection of the environment and facilitates identification of areas of cooperation at local, national and international levels.

A development-environmental scenario is usually long-term (time horizon up to 30 years) and could be regarded as a link between the present and the future through a pathway built in stages of 5 - 10 year periods. A simplified picture of the phases of a scenario preparation lists: (a) setting up an initial scenario; (b) selection of hypothesis; (c) development of a pathway; and (d) definition of the possible evolution and possible final scenarios.

An example of a regional prospective study is the Blue Plan for the Mediterranean Area. Detailed sectoral aspects of the Blue Plan were prepared in a number of volumes. Based on the methodology of the Blue Plan a number of national (and subnational) scenarios have also been prepared or are under preparation in Mediterranean countries.

4.3 Instruments for implementation

Once the Integrated Coastal Master Plan has been agreed to and approved by the government, and the individual projects have been evaluated for their environmental consequences, implementation begins. Implementation is carried out with the help of policy instruments. The instruments that can be employed for the implementation of ICAM comprise the whole range of those that are used for environmental, natural resource, agriculture, tourism, transport and energy management, as well as for land use and urban affairs. Two broad classes of instruments are distinguished: regulatory and economic. Sometimes these are supplemented with voluntary agreements between various parties (e.g. industry, tourist enterprises, environmental groups and public authorities) to achieve environmental or conservation objectives.

The guidelines can provide only broad indications for the selection of policy instruments. The instruments should, in the first place, provide strong incentives to reduce pollution and increase conservation of resources. Secondly, they should operate in such a way that the polluter bears the cost of pollution (the "polluter pays" principle) and through this the cost of environmental protection is internalized, i.e. included in the price of the products produced with polluting processes. Polluters or users of resources should in general not be subsidized. Thirdly, these instruments should ensure that users of resources (water, land, forests, fish) pay the appropriate price for them. This could be achieved with the help of user charges and resource pricing.

4.3.1 Regulatory instruments

Regulatory instruments are most widely used in environmental management and in other fields of governmental activities where the market mechanism is absent or ineffective. They reflect the "command and control" philosophy of management and until recently were practically the sole instruments of environmental management. The range of issues covered by regulatory instruments includes land-use planning, building regulations, construction guidelines for the coastline, conservation regulations, standards for anti-fouling paints for boats, fishing quotas, marine transport regulations, aquaculture requirements and licensing of various other activities.

Land-use planning, zoning and building regulations, when properly implemented, define the shape and nature of coastal development. Pollution regulations help to maintain environmental quality; other regulations define activities in a way to prevent pollution or aesthetic damage and to manage and conserve resources.

Regulations offer, therefore, a range of instruments of implementation for coastal managers but they have to be employed with two provisions in mind:

- They have to be used in the most cost-effective and environmentally most advantageous way; for every environmental objective there is a choice of instruments and their cost-effectiveness should be the guiding principle; similarly in every sector of policy the instruments available can produce different environmental benefits. In the cases when other criteria are equal, the most environmentally favourable instrument should be chosen.
- Regulatory instruments need an enforcement mechanism. For this purpose managers should be able to make use of: (i) withdrawal of permits to build (e.g. hotels or marinas), (ii) withdrawal of permits to operate (e.g. factories), (iii) imposition of effective fines, (iv) access to courts for imposition of penalties including those for damage to public health or the environment. As part of this enforcement process, monitoring of compliance is essential to assess the performance of the various actors, e.g. factories, hotels, fishing fleet, ship operators, etc.

Regulatory instruments are particularly useful when quick action is required and rules can be made quite clear to all parties concerned.

BOX 20

Regulatory Instruments: Standards

Most countries have used ambient water quality standards and effluent standards as the principal means for controlling surface water pollution. These are often used jointly in order to achieve pollution control objectives. Product standards are also used to control water pollution.

In Izmir, Turkey, the Izmir Water and Sewerage Authority (IZSU) monitors and controls industrial effluent from about 450 industries which have been analyzed and arranged in categories according to their level of pollutant discharges. The discharges must conform to the standards covering such parameters as Biological Oxygen Demand (BOD), chemical oxygen demand (COD), pH, temperature, and heavy metals. The standards have been set by the General Directorate for the Environment (now Ministry of the Environment), amended in view of the local conditions, and set out in a municipal ordinance. Once violations are detected, IZSU provides the information to the municipality, which can take legal action to fine or close the plant. A grace period is allowed if the company can provide evidence of an investment in pre-treatment. The threat of closure, usually brought about under a parallel public health ordinance, most often brings results. So far, companies have been subject to fines ranging from US\$ 400 to US\$ 20,000, and a number of leather tanneries were closed for six month-periods. About eighteen industrial enterprises have recently built pre-treatment plants, and other industries are moving to other locations. Based on the experience, the programme is off to a propitious start; it demonstrates the importance of supplementing national environmental legislation with local regulatory initiatives and ensuring the full collaboration of the local political administration. Nonetheless, the programme has encountered problems associated with the lengthy judicial process, industry inertia, and manpower and equipment shortage.

Source: Bernstein, Janis D. 1993. *Alternative Approaches to Pollution Control and Waste Management: Regulatory and Economic Instruments*. The World Bank, Washington.

4.3.2 Economic instruments

Economic instruments are used in conjunction with regulations to supplement them in areas where economic efficiency is important, where regulations failed and/or where funds need to be raised to implement public policy e.g. for environmental infrastructure. The main classes of economic instruments for coastal management are:

- *Charges* can be used to supplement pollution control regulations: e.g. effluent charges; fees for non-compliance with regulations; administrative charges to cover expenses; user charges imposed on all publicly provided services such as water supply, sewerage, harbour use, etc. to make their use efficient and to cover expenses.

- *Development taxes* are mainly used in conjunction with land-use management, and are generally imposed on highly profitable and environmentally sensitive developments such as coastal tourism. They also provide revenue.
- *Subsidies* can be granted under exceptional circumstances to finance control measures on pollution from public or private activities where such measures are urgently needed e.g. old industries. Unless subsidised, these industries would have to close. In other cases conservation measures need to be subsidized from public funds.
- *Resource pricing* is an important instrument in resource management of coastal land, coastal wetlands, forests and marine resources. This is now becoming politically more and more acceptable; it leads to a better resource management and generates revenue e.g. for purchasing land for conservation.

Some examples of economic instruments already in use in coastal areas are:

- water-space rental for aquaculture or boat marinas;
- development fees for oil and gas prospecting/production in coastal waters;
- tourist taxes to fund infrastructure (sewerage, roads, water treatment plants etc.);
- rates for urban services (refuse collection, street cleaning);
- water and sewage charges by households; with developers financing the installation of on-site sewage treatment plants.

Coastal managers would have to use a combination of these economic and environmental instruments to achieve their objectives. The combination will depend on the objective to be attained, on the institutional culture of the country and the region, and on the ability (power) of the manager to impose and enforce these instruments and to retain the money collected for waste collection and disposal in his area. His main task should be to convince local authorities and those providing services to implement policies in an efficient and politically acceptable way by using the right combination of instruments.

4.3.3 Bargaining and negotiation

Bargaining and negotiation with industry can be used in conjunction with either regulatory or economic instruments. This method is becoming ever more frequent in dealing with one particular industry group or with an industrial association on a regional basis.

Specific agreements with industry or other groups, e.g. tourism associations, can be particularly useful instruments in coastal areas where more stringent pollution or conservation standards might be needed which can be imposed nationally but can be negotiated locally.

4.3.4 Conflict resolution or techniques for consensus building and integration

The high social value associated with coastal areas and the rich private returns provided by past development are likely to generate numerous and severe conflicts in the future. Some of these conflicts are of a "vertical" nature, i.e. they occur between the authorities and interests at various levels (international, national, regional, and local), while others are "horizontal" conflicts between the users and activities at one and the same site or at adjacent sites. Especially important are the conflicts between the interests of individual users of coastal resources and the coastal population at large. A reasonable and just solution to such conflicts is one of the most important objectives of any coastal area management.

In practice, the conflicts are resolved every day within the administrative, legal and social framework of a coastal area. However, the resolution of more important conflicts requires special

techniques and it is the task of the government and coastal managers to create the framework, assure access and make use of these techniques, which are basically of two types: arbitration and legal procedures.

Within the arbitration system there are procedures for working through administrative and independent arbitrators:

- (a) Formation of an *ad hoc task force* (commissions, scientific bodies) for resolving a particular problem; this can be implemented at all levels and its efficiency depends on factors such as members selected, set of objectives, level of authority, and funds available. In most cases such bodies propose solutions, while decisions are left to other authorities.
- (b) Formation of *long-term or permanent bodies* to monitor a particular process, orient it and even resolve the conflicts: interministerial councils, interagency councils, local authorities' councils. Such bodies are often entitled to take decisions and they also carry the public responsibility for those decisions.
- (c) Generation of a *policy dialogue* through discussion among interested parties in potential conflict is often used by moderators or facilitators. The special value of this technique is that it can provide a relatively objective insight into the various interests of the different parties while the possible consequences of the decisions can produce additional information and find the basis for compromise solutions.
- (d) Nomination by the authorities of *qualified intermediaries* when a dialogue is impossible or has been interrupted. Their role is much more active and responsible than that of facilitators as, in many cases, they propose their own solutions after they have heard all parties and studied all individual interests.
- (e) Creation of an *arbitration procedure* is used for cases where it is impossible to find a solution through negotiations (environmental mediation). Legal authority or the consent of the interested parties is an essential prerequisite for its application. Decisions of the arbitrators bind all parties and therefore their impartiality and their ability to understand the issues are basic to the arbitration process.

Solution through legal procedure is used in cases when all other techniques have failed and one of the parties requests legal protection or claims rights he believes he is entitled to. The principal shortcoming of the legal procedure is that it is usually long and expensive and that sometimes it is not capable of using highly complex technical information in an appropriate manner.

In certain cases involving international issues international arbitration is required which might be pursued with the help of a mutually accepted arbitrator or through the courts.

ANNEX I

SOME BASIC DEFINITIONS RELATIVE TO ICAM

In the practice of ICAM, there are a number of notions used by planners, managers, decision makers and the general public, all of which would be impossible to define in a limited textual space. Nonetheless, there is need to define the fundamental notions which are most frequently used both in practice and in the referential bibliography. The objective of this Annex is to familiarize the users of these guidelines with these basic notions.

Coastal zone and coastal area

The term "*coastal*" is, in the majority of cases, defined as a "*sea-land interface*" or "*a place where land, water and air meet*". Consequently, a "*coastal zone*" is most frequently defined as "*land affected by its proximity to the sea and that part of the sea affected by its proximity to the land*" or, in other words, the area where the processes which depend on the sea-land interaction are the most intensive. This interface is taking place along two axes: the axis running along the coast and the axis perpendicular to the coastline. In terms of the basic definition of the coastal zone, there is little controversy related to the coast-wise axis, since it enables an easy definition of the boundaries of the coastal ecosystems. Quite the contrary, there is much dispute with regard to the cross-shore axis. Thus, definitions of the coastal zone vary from those covering the entire watershed areas in the hinterland part of the coast to those including a narrow coastal strip only. In any case, the definition of the boundaries of a coastal zone depends on criteria stemming from the goals of the ICAM process.

"*Coastal area*" is a notion which is geographically broader than the coastal zone, the borders of which require a less strict definition. This notion indicates that there is a national or sub-national recognition that a distinct transitional environment exists between the ocean and terrestrial domains. This notion is of extreme importance for ICAM. Many processes, be they environmental, demographic, economic or social, actually take place within the boundaries of the coastal area, with their extreme manifestations being most visible in the area of the coastal zone.

A graphical presentation of the elements of the coastal zone and the coastal area is given in the figure below. "*Ocean waters*" cover the largest part of the sea belt, up to 200 nautical miles off shore (Exclusive Economic Zone). "*Coastal waters*" cover a narrow near-shore sea belt, its width varying from one country to another (in the United States this belt is approximately 3 miles wide). "*Intertidal area*" is the area between the lowest tide line and the shoreline (the landward extent of the tidal influence), including estuaries and coastal wetlands. "*Coastline*" is the contact line dividing the land from the water bodies. It usually coincides with the line marking the landward extent of tidal influence. "*Oceanfront or shorelands area*" is part of the land up to the highest line of tidal influence. This is a relatively narrow belt, with its inner borders usually reaching the first coastal road or encompassing the areas reserved for the public access to the coast, protection of sensitive habitats, etc. This belt is rarely wider than 1,000 m. "*Coastal uplands*" are defined as an area of the interior between the shorelands and, most frequently, the highest peak of the closest mountain range. Sometimes, the depth of the belt is limited (in the United States the limit is 5 miles). "*Inland*" may be any area outside the

aforementioned belts. However, it should not be considered as an altogether unimportant zone, since many processes affecting the state of the coastal zone originate in that area. Generally speaking, that coastal waters, intertidal area, coastline, shorelands area and coastal uplands are the elements of the coastal zone. In addition to the coastal zone elements, the coastal area contains the ocean waters and the inland area.

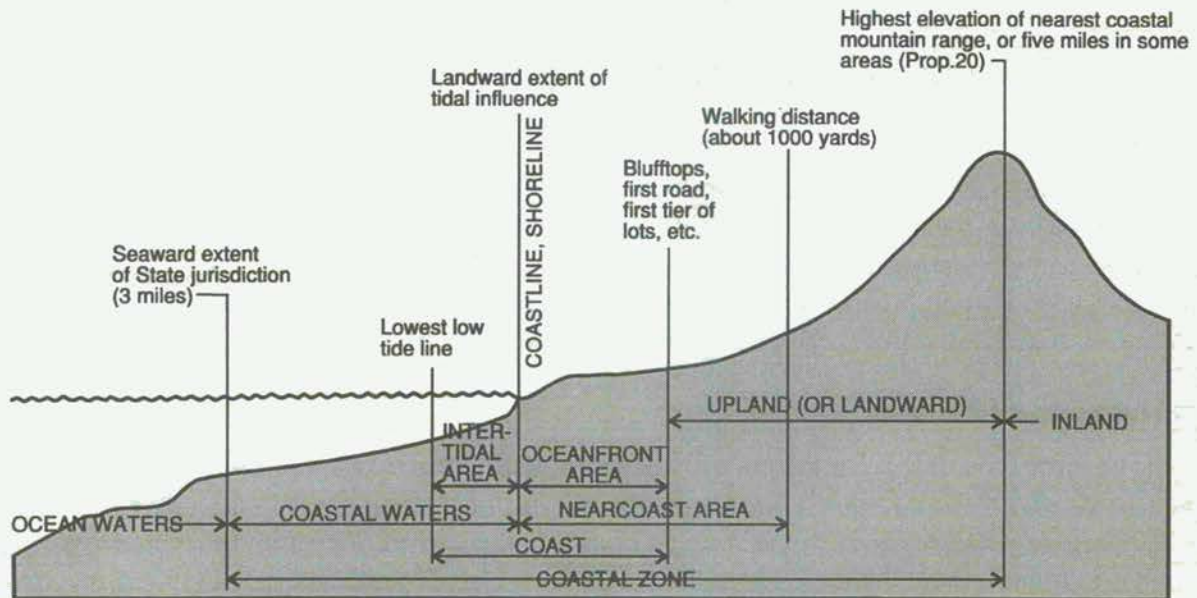

Figure 5. Parts of the Coastal Area

Source: California Coastal Zone Conservation Commissions. 1975. California Coastal Plan. California Coastal Zone Conservation Commissions, San Francisco, U.S.A.

Carrying capacity

Carrying capacity is most frequently defined as the maximum number of users which can be sustained by a natural or man-made resource without endangering the future productivity, character and quality of that resource. Carrying capacity is a relative concept, its definition is dependent on the practice of managing the given resource as well as the characteristics of the user and the original state of the resource. This means that any capacity assessments are dependent on the management goals, ways the resource is utilized and the standards required by the potential user of the resource. A realistic assessment of the capacity is rather complex and frequently dependent on an arbitrarily set threshold beyond which the environmental consequences of overuse are considered undesirable. Thus, the capacity assessment is largely dependent on the value judgments of those who are determining them (managers, decision-makers, the public, etc.).

The concept originates from the ecological studies where the users were plants. It was later used in agricultural studies (definition of the animal:land ratio, population capacity for agricultural land, etc.), traffic studies and, recently, in studies defining the capacity of tourist areas.

Because of the growing interest in the use of coastal resources and the vulnerability of coastal ecosystems, the carrying capacity concept is of considerable importance for ICAM, although it is hardly possible to arrive at exact figures. By defining the carrying capacity for tourism, for example, it is possible to get the framework for managing a certain area in the physical, economic, environmental, social and behavioural sense.

Within the context of this definition, a mention should be made of the notions of the "assimilative" and the "sustainable" capacity. The term "assimilative capacity" applies in the cases when the environmental media are used, deliberately or unintentionally, for discharging waste materials from human activities. Natural systems can only absorb a certain volume of residues of different kinds over certain times without being adversely affected. The concept of assimilative capacity has to be applied, for example, in the case of untreated or treated liquid waste being discharged into a marine environment. The notion of sustainable capacity applies in the cases of renewable resources (fisheries, for example), when the use of these resources has to be allocated over time to enable their use by future generations. The practical application of both concepts, assimilation and sustainability, departs from those principles respected in defining carrying capacity.

Coastal resources

A resource is *something material or abstract that can be used to satisfy some human needs and desires, or make up for lacks of it*. Basically, resources are divided into natural, human and man-made. However, in the context of resource management, this term is reserved just for substances, organisms and properties of the physical environment (natural resources). The term is only used when: (1) there is knowledge and technological possibility to utilize something, (2) there is a wish to utilize something. It can be said that resources are a cultural concept, and that some things that are considered resources by some societies do not necessarily have to be treated in the same way by others which lack the wish or knowledge to utilize them.

Another important division of natural resources is between stock and flow resources. *Stock (or non-renewable)* resources are those which have taken million of years to form and cannot reproduce themselves at a rate meaningful to people (minerals and land). *Flow (or renewable)* resources are those which naturally regenerate to provide new supply units within a human time-span. However, whether a resource belongs to one category or another depends only on man's decision and can be changed.

A coastal resource is most frequently defined as a *natural area or feature in or near a coastal zone, the existence of which depends on the coast*. The value of that resource, if treated as a commodity, grows because it is located in the coastal zone when the resource has economic, environmental, recreational, cultural, aesthetic or any other value for humanity.

Coastal zones feature a large variety of coastal resources. *Coastal waters* contain the greatest variety of marine resources and water birds, as well as significant recreational, transport, cultural and aesthetic values, aquaculture potentials, etc. *Coastal land* consists of sand dunes, headlands and cliffs, reefs, bluffs, bays, lagoons, wetlands, flatland and hilly or mountainous area, etc. The most important resources of *inland surface waters* are watersheds and freshwater supplies.

Most frequently, coastal resources are renewable. For the requirements of ICAM, it has to be pointed out that they behave as systems, that there are interactions between them, that they can be utilized in many ways, that between the various kinds of their utilization there can be complementarity or conflicts, that they supply private goods as well as public goods, etc. The coastal resources have to be at the disposal of the present, and remain at the disposal of the future generations. Sustainable utilization is a prerequisite for this continuity. This implies a perception and understanding of coastal resources as a capital investment with an annual yield, where the yield and not the resource is being utilized.

Sustainable development

The origins of the concept of sustainable development can be traced down to the moment when first doubts emerged about the prospects of unlimited economic growth, especially when it was realized that the environment had a limited capacity, both as a resource and as an absorber of residuals. The first debates, in the early 70s, had a catastrophic connotation, presenting society with the dilemma of choosing between economic growth or protection and improvement of the quality the environment.

In the early 80s, a significant step forward was made in the debates. First, the focus was put on a possible complementarity between economic growth and the environment. Then the term "economic growth" was replaced by the more complex and appropriate term "economic development".

It was the *World Conservation Strategy* prepared by International Union for Conservation of Nature (IUCN) in 1980 that first introduced the term "sustainable development", but it failed to integrate economics with environment. This concept achieved its definitive affirmation through the United Nations Conference on Environment and Development (UNCED) held in Rio in 1992.

The term itself does not cause many controversies. Development is a certain set of goals and objectives for society. It is more than mere income growth or economic growth; it means improvement of the quality of living. Sustainable development implies such socio-economic system which secures that these goals are sustained. Also, there is a consensus on the basic principles of this definition: an awareness of future needs, concern for the environment and equity. An awareness of future needs means that care should be taken of the long-term consequences of present human activities; concern for the environment means that environmental values have to be taken into account, because conservation of the environmental quality is one of the foremost development goals (quality of life); while equity refers to providing for the needs of all social strata today (intragenerational equity) and equitable access to resources for future generations (intergenerational equity).

Due to the complexity, sensitivity and limitations of the natural systems, and the value of the natural resources, coastal zones and areas fall under those environmental domains in which it is particularly important that the concept of sustainable development is applied. Accordingly, the basic principles of that concept must be reflected in the practice of ICAM.

First, it must not to be viewed as an exercise to be performed then abandoned, but as a process consisting of a number of common rules of environmental behaviour. ICAM aims to provide an effective instrument for achieving a balance between social and economic development and the protection and rational use of coastal resources.

In implementing sustainable development in coastal areas through ICAM, several aspects of the sustainable management of resources have to be addressed, namely:

- what should be the *critical stock* of coastal resources to deliver sustainable outputs;
- what should be the *critical level of quality* of coastal resources compatible with the critical level of stock to deliver sustainable outputs;
- what species and ecosystems need to be *preserved*, and at what level, to provide their output on a sustainable basis;
- what are the factors and what should their level be to maintain the *quality of life* in coastal areas on a sustainable basis?

Finally, a set of precise policies must be defined in order to make the implementation as efficient as possible. UNCED's *Agenda 21* provides detailed instructions for that.

Integrated coastal management

Resources of coastal zones and areas provide a flow of goods and services, but often include a variety of complementary and inconsistent activities. If left alone, social and economic forces at work in coastal areas competing for scarce resources would result in overexploitation of resources, negative environmental effects, equity problems and a loss of social well-being. Therefore, coastal zones and areas require management.

Coastal zone management is an activity within the broad field of resource management. Resource management may be defined as a conscious process of decision-making whereby natural and cultural resources are allocated over time and space. This allocation aims to optimize the attainment of stated objectives of a society, within the framework of its technology, political and social institutions, and legal and administrative arrangements.

The differences between the coastal zone management and other kinds of resource management are (1) in the fact that the field of activity of the coastal zone management is a specific geographic area, and (2) in the issues dealt with. Furthermore, the rich mix of human activities, natural resources and tightly linked ecological processes in coastal zones and areas, and the resulting problems and conflicts cannot be addressed by traditional single-sector approaches. Multisectoral and cross- sectoral, or integrated coastal zone management becomes a necessity.

There are numerous definitions of this activity. The one defining it as a process of achieving goals and objectives of environmentally sustainable development in coastal areas, within the constraints of physical, social and economic conditions, and within the constraints of legal, financial and administrative systems and institutions seems the most comprehensive.

ANNEX II

MEDITERRANEAN COASTAL RESOURCES AND THEIR PROBLEMS

The classification and analysis of coastal resources pose a methodological problem. Each profession or discipline chooses its own basis for classification and it is consequently very difficult to suggest a satisfactory multidisciplinary classification. Most attempts to do so use a combination of characteristics aiming to achieve a division useful for planning and management purposes.

Classification of coastal resources

Geological and geomorphological classifications usually provide the macro-division of coastal resources. They refer to large-scale formations and major long-term processes. Colliding coasts are characterized by steep cliffs fronted by narrow continental shelves. Spreading coasts are characterized by lagoons and wide continental shelves. A further subdivision may be defined by morphological features eg. estuaries, islands, and further detail added by characteristics generated by wave and tide action, eg. beaches.

Ecological classifications are based on the interactions of organisms and their environment, through the flows of nutrients and energy. High productivity coastal ecosystems, such as wetlands, are of greater importance as coastal habitats than low productivity beaches. Ecological characteristics of coastal ecosystems pay attention to favourable or stress conditions for the normal development or degradation of the habitat, such as space, light, temperature and nutrients.

Hydrological and hydraulic classifications are based on the quality and quantity of water flows. Coastal engineers classify coasts according to their exposure to wave energy and to the supply, transfer and loss of sediment. Hydrologists classify coasts according to the level of enclosure (lagoons, embayments, types of estuaries) and to the characteristics of the water bodies (salinity, turbidity, chemical and biological content).

Man-made resources are based both on elements created by man's activities - historical and archaeological resources - and on visual perception of the landscape or urban design - visual resources.

Multidisciplinary classifications of coastal resources frequently refer to the zones of transition from maritime resources to terrestrial and riverine resources, as follows:

- deep sea and seabed resources;
- the continental shelf;
- coastal waters, inland seas and embayments;
- the inundation zone, intertidal zone or coastal floodlands;
- the foreshore, beach, cliff, and the spray zone; - estuarine lands;
- coastal uplands, dunes and areas beyond the spray zone;
- coastal watersheds.

Coastal zone management usually requires a classification which combines characteristics of coastal resources both with geographical areas and with systems for management. An example of a possible classification follows:

- Large-scale geomorphic or oceanographic systems, such as the subsidence or emergence of tectonic plates or coastal ocean currents;
- Estuary watersheds, including ground and surface water flows and practices affecting water quality and quantity;
- Estuary circulation systems, concentrating on discharges of wastewater and its impacts on water quality and biota;
- Ocean basins, where particular attention should be given to direct discharge of pollutants to the ocean water and the impacts of estuary pollution on ocean waters;
- Longshore circulation cells, coastal erosion and deposition where control of coastal erosion is of particular importance and where special attention must be paid to erosion - accretion dynamics;
- Populations of commercial and sport species, with the management problems generated by the degradation of their habitats by pollution, by loss of wetlands or by over-exploitation;
- Viewsheds, with attention to obtrusive and obstructive development;
- Public service systems, to guide development according to the capacity of water and sewerage systems and to prevent damage to life and property in hazard prone areas.

It is not really feasible to suggest a universal classification of the multiple interlinking systems of coastal resources which would always provide an appropriate basis for coastal zone management in every part of the world. The foregoing paragraphs have identified which items could be relevant but the combination of characteristics of importance will differ from country to country, depending on the resources present and the management problems encountered. The following sections describe and analyze the resource management issues common to most coastal zone integrated planning processes, mainly in the Mediterranean basin.

Sands and dunes

Natural beach processes create natural defenses against attack by waves, currents and storms. The sloping near-shore bottom causes waves to break offshore, dissipating energy while rushing up the beach foreshore up to the ridge or crest of the berm. The upper flat beach is only reached by storm waves. There is a direct relationship between energy of the waves and the sand grain size. Larger particles are found on high energy beaches. Beach sediments range from fine particles, carried in suspension, to coarse pebbles and cobbles, depending on their source and longshore transport by waves and currents. Beach characteristics are usually described by particle size and composition, width of sand beach, steepness of foreshore, presence of sandbar or existence of barrier islands.

Well developed sandy beaches are by no means scarce resources, but their conservation is an important part of coastal zone management. The beach area is dynamic, adjusting according to changes in wave energy both under normal conditions and under storm conditions. Sand will be deposited where wave energy is dissipated; sand will be removed from the beach where wave energy is not satisfactorily dissipated and the remaining energy erodes beach berms or dunes, particularly under storm conditions. Under natural conditions, the beach will undergo periods of stability, where sand supply equals sand loss, and periods of erosion followed by periods of rebuilding. Alternate erosion and accretion are part of normal dynamic coastal processes. So are

movements of sediments along the shore, known as littoral transport, which are both parallel and perpendicular to the shore.

Sandy beaches are a relative hostile environment; their ecosystems are of relatively low bioproductivity compared to wetlands. The beach is an area in constant motion, poor in organic matter and lacking the essential nutrients necessary for the development of a well established food chain. As grain size decreases towards slit and mud and retained organic matter increases, an increase in species numbers and diversity is found. As a resource, sandy beaches are of extreme importance to recreation and tourism activities, where the presence of wide gently-sloping, fine sand beaches can provide the essential element for economic development. The beach then becomes highly sensitive to pollution which could reduce its attraction to visitors.

Coastal dune systems are of greater ecological interest and are highly sensitive to damage by human activities. Their survival now depends on maintaining a plentiful supply of sand, and on the vegetation which enables its stabilization.

Banks, cliffs and bluffs

Banks, cliffs and bluffs are frequently formed by rock formations or semi-consolidated rocks, and are vulnerable to erosion by processes at the toe of the slope and at the top. Currents and wave action at the toe directly undercut the cliff face, undermining the stability of the cliff and creating notches or overhangs. When the overburden becomes unstable, possibly as the result of weathering or as the result of seepage or accelerated infiltration of surface water, adding weight and causing lubrication at the head of the cliff, the cliff material slumps, slides or falls. Material accumulated at the base of the cliff will then be removed by wave energy.

Bays, lagoons and estuaries

The most productive and most vulnerable coastal areas from an ecological point of view are the "wet" ecosystems, the interfaces between marine, terrestrial and riverine habitat. Upper wetlands contain salt tolerant plants, capable of withstanding flooding by tides. They store nutrients and organic detritus. Lower wetlands collect and store dissolved mineral nutrients; plant tissue is washed out into coastal waters. Wetlands are particularly important as habitats for shore and wading birds. The mixing of freshwater from land-based sources with seawater, creating water systems of varying salinity, together with variations in bottom composition (fine mud sediment to coarse sand particles) influences the type of coastal wetlands.

The management of coastal wetland resources should recognize the important characteristics which influence the carrying capacity of the ecosystem, such as:

- (a) **Shelter:** wetlands develop in areas protected from wave action or at low energy coastlines where wave energy is well dissipated. Protection enables the retention of suspended particles and living matter.
- (b) **Light penetration and turbidity patterns:** shallow waters and the amount of suspended particles, detritus and organisms are important factors in determining rates of photosynthesis.
- (c) **Salinity:** mixing patterns and saltwater intrusion influence the diversity and distribution of biota.
- (d) **Circulation:** water movement and the transport of suspended plankton are important for the maintenance of wetlands. Tidal flux may be particularly important for transporting nutrients and flushing out wastes.

- (e) **Storage:** wetlands develop in areas of high nutrient cycling where they can store nutrients for later use.

Visual coastal resources

Visual coastal resources are those images which become valuable through man's visual perception of them. Visual resource value may not necessarily coincide with the foregoing resource values identified in this annex; it may be another facet of their importance in coastal zone management. Most of the methodologies used in landscape analysis include a combination of characteristics which contribute to visual diversity, and to visual harmony.

Visual diversity of line, point and area features is particularly strong along the coastline, due to:

- contrast between land areas and water areas, between gentle shores and steep cliff edges, between vegetated surfaces and exposed rocks;
- multiple topographic, vegetation and water interfaces as environmental conditions change from marine to terrestrial and riverine habitats;
- vividness generated by the dynamic movement of waves, spray, flowing water, light and shade;
- vibrant colours with a combination of blues (water), greens (vegetation), yellows (sand) and browns (rocks).

Visual landscape value is also found in characteristics which contribute to visual harmony, including:

- continuity of the open sea water surface and continuity of the coastline;
- congruity of lines, patterns, shapes and sizes of natural and man-made elements and structures which blend together, complementing each other.

Historical and archaeological resources

The coastal zone is rich in the remains of civilizations, leaving remnants of maritime activity and of coastal activity. Coastal civilizations focused on shipping, shipbuilding, fishing, trade and commerce, harbour installations and port related industries.

Underwater remains include:

- wrecks of ships and their cargoes;
- submerged harbours;
- sunken cities, the result of eustatic changes in sea level.

The seabed in many cases, preserves underwater antiquities by layers of sediment and by the lack of oxygen which slows the process of degeneration of wood, metal or organic materials.

On land, coastal civilizations have left monuments of their built structures, including harbours, storage facilities, aqueducts and the public and private facilities of flourishing urban centres. Coastal zone management should identify and conserve historical and archaeological remains for this and future generations.

Islands

The most comprehensive definition is that islands are parts of land surrounded by ocean, sea or lake water. The main feature is geographic isolation which, in spite of the variety of island

situations, is the principal attribute of the uniform term of "insularity". This term has its physical and socio-economic dimensions.

Islands are characterized by a high coast-to-land ratio, so that they are treated, almost as a rule, entirely as coastal areas. Island eco-systems are vulnerable to external influences. They are also characterized by a high degree of biodiversity.

Island economies necessarily have open, simple structures, highly dependent on the import component, and their development is often influenced by decisions taken thousands of kilometers away. Development problems of a majority of islands result from the fact that economic constraints imposed by their size and isolation dictate the development of only those economic sectors which are based on the exploitation of natural resources, such as agriculture, fisheries and tourism.

Over the last few decades, on many islands, tourism has been viewed as almost the only economic sector likely to develop . This development thrust caused an increased demand for local natural resources, not only due to the increased number of occasional population, but also to a rising affluence and expectations of, sometimes rapidly growing, local population. Carrying capacity for tourism is of a limited extent, and very often not defined at all or not properly. Signs that the limits of carrying capacity have been approached, hindering sustainable development, are: uncontrolled urbanization, infrastructure breakdown, environmental deterioration, and increased social collapse and impoverishment. Remoteness and isolation no longer guarantee freedom from signs of environmental deterioration such as coastal water pollution, offshore oil spills, ocean dumping, destruction of habitats and indigenous species, inappropriate coastal architecture, etc. It can be concluded that, in spite of abundance of some natural resources, islands are vulnerable to a development planning which has not taken into consideration the overall balance of island resources which should sustain such development.

ANNEX III

DATA BASE MANAGEMENT

Data represent real world facts or phenomena. They may be records of geographic features of events gathered from primary (field survey) or secondary (census) sources. Data are transformed into information through a data processing system (DPS).

Any DPS should have the following components:

- operating environment: definition of users, their needs, data needed, kind of decision making;
- perceptor apparatus: instruments by which data can be entered and up-dated;
- storage, processing and output devices;
- effector apparatus providing the information products (maps, tables, diagrams, etc.).

A DPS can be designed for multiple and varied users ("library", supply mode) or for specific purposes (function mode).

The organization of a Data Base Management System (DBMS) depends on the nature of its sub-systems for perception, storage, processing and retrieval, its basic aim being to provide efficient access to data, reduce redundancy and maintain the integrity of its data base.

There are four basic database organizational models:

- A hierarchical database, a tree model with no links or loops between different branches;
- A network with an emphasis on the lines of connectivity between data;
- Relational tables which provide links between different elements in the database;
- Object-oriented models, by which the database is designed to provide a functionally-oriented product.

The DBMS selected may include some or all of the above properties.

The development of information systems as decision support started in the 60s with the application of Electronic Data Processing (EDP) and continued in the 70s with the development of Management Information systems (MIS) and Integrated Management Information System (IMIS), the latter implying integration of information and organizational components. At the beginning of the 80s, a new generation of systems started to develop, namely, Decision Support Systems (DSS). DSS is a sophisticated new technology of management, integrating the informatics, operational research and systemic analysis. DSS requires a powerful information base, high-level expertise and professional teams, the involvement of a large number of disciplines and considerable financial resources.

One of the most frequently quoted definitions of DSS is that it is a computer based information system that helps a manager make decisions by providing him/her with all the relevant data in an easily understandable form. As DSS user, the manager formulates the problem

by using an interactive and (probably) menu driven front end. The system then accesses a database to locate the necessary data, utilizes a repertoire of mathematical and/or statistical models, and, finally, produces the derived information at the user's terminal. The user can explore several "what-if" scenarios in order to arrive at a decision.

The majority of successful applications of DSS are now concentrated in the business and corporate domain which tolerate a narrower approach to the system building.

ANNEX IV

INTEGRATED PLANNING STUDY FOR THE ISLAND OF RHODES

Introduction

The Integrated Planning Study for the Island of Rhodes, being prepared by PAP/RAC within the MAP Coastal Area Management Programme (CAMP) "The Island of Rhodes", has the nature of an "umbrella" document which, apart from planning proposals, will integrate the results of other activities performed within this CAMP.

The Study is the first and major step towards the launching of the process of integrated planning and management of coastal resources of the island of Rhodes. Former planning activities in the island were mostly aimed at defining global aspects of development, often with sectoral orientation and a short planning period. So far, there have been no significant environmental problems, but there are indications that they can be expected in future. In the planning documents prepared hitherto, environmental aspects of development did not have a prominent place. One of the principal objectives of the Study is the integration of environmental considerations into the earliest phases of the planning process, as well as to ensure that all planning actions are verified through the assessment of their possible impacts on the environment and use of natural resources. That would make a good basis for the implementation of the concept of sustainable development of the island.

The Study is a practical planning and management tool for: (a) quick identification of major development and environmental issues; (b) definition of an outlook of the most feasible future development of the island on the basis of the assessment of the capacity of the natural resources to sustain human interventions; (c) proposing spatial strategies of the development of the island along with appropriate management actions; and (d) proposing measures for taking immediate actions.

Most of the planning proposals are made at the level of community associations or communities themselves. Together with some other activities of the CAMP, the Study offers an excellent basis for the implementation of such concrete actions in the future.

Organizational background

For the preparation of the Study, a working group has been formed of the experts of the Ministry of the Environment, Physical Planning and Public Works, the Prefecture of the Dodecanese, and the Municipality of Rhodes, as well as a number of international experts engaged by PAP/RAC. The work started in June 1991. Three PAP expert missions visited Rhodes (each lasting 3 weeks) with the objective of setting up major phases of the Study preparation. In the interim periods, the local and national experts were preparing sectoral reports which were used for the preparation of the final report of the Study.

Major issues in former development and state of the environment of the island of Rhodes

Within the first phase of the Study preparation, the activities were concentrated on the identification of the basic issues in the changing context of the development and environment of the island. At that, only the available data were used, which were brought into the GIS database, which was then used for analytical procedures. Although some phenomena were analyzed sectorally in the first place (population, economy, spatial structure, natural systems, environmental management, etc.), a high degree of integration between them was achieved so that their mutual impacts and effects had been identified wherever possible. Also, for some issues, apart from the analysis of hitherto processes, trends were presented of a future development, based exclusively on the present growth rates. The objective of this procedure was to point out, at an early stage of the Study preparation, some of the problems which can be expected in the future if the present trends continue.

The major issues to be taken into consideration when planning the future development of the island, were identified as follows:

- ***Over-dependence of the island economy on tourism.*** Employment structure, urbanization processes, and investment policy are indicators of a long-term orientation of the island to the development of tourism. Apart from the obvious benefits of such a development, some problems start appearing, such as: a general lack of local labour force and migration processes; concentration of the population in the northern triangle of the island, and a relative decrease of population in many settlements of the island (especially in its southern part); dependence on investment decisions made outside the island; rigidity of the island economy with regard to the changed conditions at the market; declining hotel occupancy rates and declining income markets.
- ***Emerging processes of environmental degradation.*** Although the general environmental situation can not be defined as unfavourable, there are some disturbing indications. It can be noted through increased sea and water pollution; salination of water resources; forest fires and resulting soil erosion; overbuilding in the northern part of the coast and generally uncontrolled construction of tourist establishments, often without a building permit; and problems of historic settlements management.
- ***Inappropriate use of natural resources.*** The unbalanced socio- economic development had strong effects on the practice of resource use, especially on the use of land and water resources. In some parts of the island, land-use conflicts have already appeared as a result of the search for space for economic and other human activities (location of solid waste disposal sites, coastal land encroachment, threatening valuable ecosystems, etc.). The water resources have become an ever more limiting factor for the development. First, they are unevenly distributed over the island, and second, the increased demand due to the growth of tourist activities causes an accelerated rate of its use, as well as a number of associated environmental problems.
- ***Fragmented institutional structure of environmental management.*** Although the management role of the central Government is highly pronounced, there is a lack of coordination between the various departments in charge of environmental management. Practically, the implementation of physical planning system on the island is very weak, either because a well developed planning system is missing, or because there are no clearly defined procedures or instructions for regulating agencies which deal with environmental matters. The system of inspection and environmental law enforcement is loose.

Options for the future

In the second phase of the Study preparation, a number of possible options of the future development of the island were generated. Two target years have been established: 2000 (for proposed management actions) and 2010 (for long-term planning actions). With regard to the action character of the Study, projections into the future, beyond the target years were considered purely speculative. On the other hand, within this CAMP, environment-development scenarios were prepared by MAP's Blue Plan Regional Activity Centre, with the main objective of exploring the possible development directions on a longer term.

In defining long-term development options, a number of major indicators were used (population, labour force, employment structure, tourism, environmental objectives, impacts on the use of resources, etc.). Furthermore, two major sets of objectives were established in order to assess alternative options: environmental quality objectives and income growth objectives. Therefore, three options were identified:

- (1) Continuation of the current development pattern (*Economic Growth Option*). This option adopts as its starting point the existing trend in the growth of beds until the year 2010. The number of tourist beds is the key component because it determines the level of activity in the rest of the economy. The main conclusion to be drawn from this option is that the pressure on the natural resources of the island will continue. The local labour supply will not be able to provide the labour force required by the growing number of beds, and the rise of the tourist receipts will rise only marginally.
- (2) Alternative development option I (*Environmental Conservation*). This option is based upon the sharp reversal of existing development trends, practical moratorium on new tourist accommodation, sharp reduction of incentives to tourism, and strict planning control and land-use standards. The expected consequences are increased protection of the environment but with slow-down of economic growth, reduction of employment opportunities, marginal increase in tourist receipts, and some negative political reactions. New policies would need to be established for some other sectors of economy, like agriculture, which should replace tourism as the main pull economic factor.
- (3) Alternative development option II (*Sustainable Development*). To achieve this option it is necessary to combine a slower growth of tourist beds within a controlled growth strategy, designate "target development areas" and "conservation areas", enforce land-use/density standards, implement coastal zone management, achieve sustainable employment growth, diversify incentives to tourism, diversify "tourist product" and achieve growth of tourist receipts. The implementation of this option will depend on an active environmental management programme and new tourism policy. But, above all, it requires a spatial strategy where allocation policy will direct planned construction development to selected locations according to capacity criteria and environmental standards. Such a policy could ensure protection of the environment, continuation of a moderate economic growth and employment, with increasing diversification of investment opportunities.

It is obvious that, assessing by environmental quality and income growth objectives, the option based on the sustainable development of the island of Rhodes should be the preferred one. The implementation of this option requires an efficient spatial strategy. Starting from the existing development problems, the island is divided into three distinctive areas, namely:

- saturated zone (the coastal zone from Kalavarda to Lindos);
- non-saturated zone (the coastal zone from Lindos to Prassonissi);
- hinterland zone (south-western part of the island).

The Study lays out the general policy guidelines for each zone in relation to the principles of the protection of the environment and rational use of resources. Therefore, three types of policy guidelines are proposed:

- Rehabilitation (in the saturated zone),
- Controlled development (in the non-saturated zone), and
- Conservation (in the hinterland zone).

Management actions

Based on the above spatial differentiation of the island, the Study proposes a number of management actions. Those proposals cover a large number of sectoral activities:

(1) Spatial planning

- development of the settlement system
- land use
- transportation

(2) Environmental management

- environmental administration
- environmental education
- economic instruments of environmental management
- natural parks and natural reserves conservation
- general waste management programme
- water management programme
- noise prevention and air quality control
- energy programme
- fire hazard management
- natural hazards and risk management
- planning for climatic changes
- environmental monitoring and research

(3) Recommendations for immediate action

- priorities for implementation
- institutional implications
- financial implications.

These proposals have been offered to the local, prefectural (regional) and national authorities for implementation.

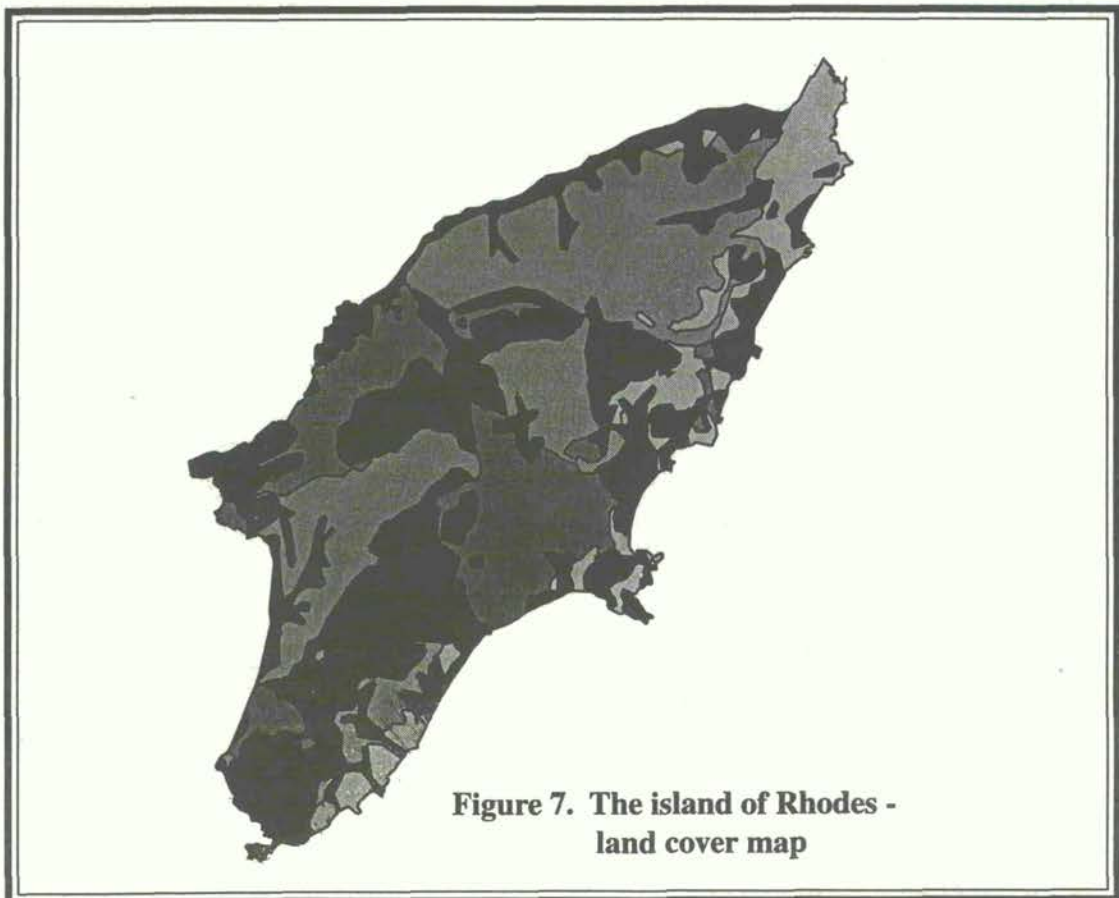
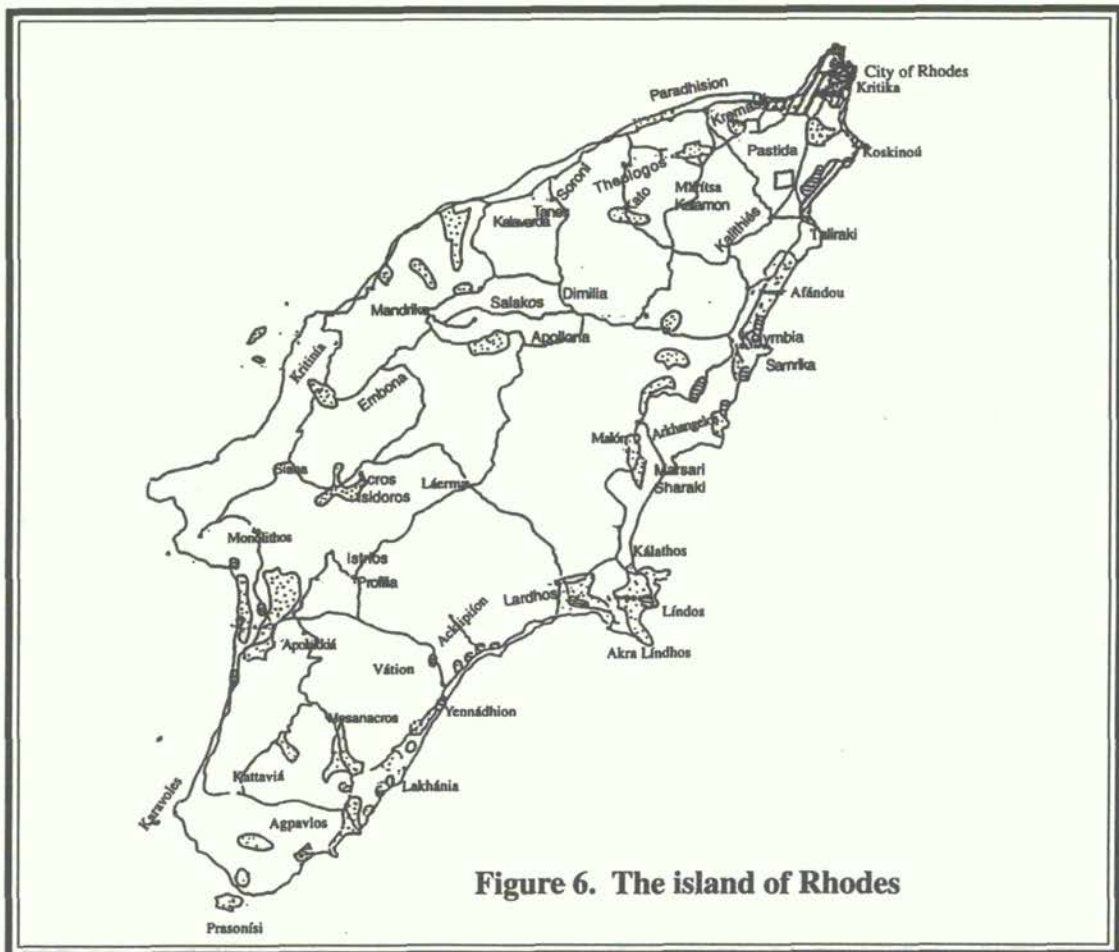

ANNEX V

ISRAELI NATIONAL OUTLINE SCHEME FOR THE MEDITERRANEAN COAST

In 1970, the National Planning and Building Board recognized that Israel's coastlines should be treated as resources of national value, and issued an order for the preparation of national plans for all its sea and lake shores: the Mediterranean Sea, the Red Sea (Gulf of Eilat), the Sea of Galilee and the Dead Sea.

The first stage of the National Outline Scheme for the Mediterranean Coast was approved in 1983. The main objectives of the plan were to prevent development which had no connection to the coast, to protect large sections of the coastline as nature reserves, national parks and coastal reserves, and to allocate coastal areas for tourism and recreation activities. The masterplan included a highly effective clause prohibiting development within 100 meters of the coastline. Relaxation of this regulation is occasionally permitted only if approved by the national board.

To help provide a comprehensive long-term guide to planning policy, beyond the general guidelines in the approved masterplan, the national board commissioned a more detailed document for the resource management of the Mediterranean coastline for tourist and recreation activities. This resource management plan, prepared by the Ministry of the Environment, was recently submitted for approval to the national board.

The plan is based on principles of suitability and sensitivity of coastal resources. The dominant principle adopted for resource management of the coast was the definition of intensity of development. A natural, undeveloped bathing beach offers a totally different experience from an urban beach with multiple visitor facilities. Similarly, overnight accommodation at a village camping site is a different experience from accommodation at a central urban hotel. Five levels of development were therefore defined for beaches and their immediate hinterland, four levels of intensity of accommodation, and three levels of development of hinterland day- visitor areas.

Each site designated for tourist and recreational use was allocated a level of intensity of development, initially proposed by the planners on the basis of surveys, geological and ecological guidelines, and local site conditions. Alternative proposals were checked to determine whether the level of development proposed would damage sensitive resources on or near the site. Where a conflict was identified, the level of intensity was reduced, the boundaries of the development area changed, or the site cancelled and an alternative selected.

The overall national policies proposed for resource management of the coast include:

- development which is not for recreation or tourism should not be permitted along the coast and its immediate hinterland;
- policies for resource protection should range from absolute protection within a designated reserve to the identification of sensitive resources to be considered within the detailed plan for site development;
- highly intensive uses should be confined to existing urban centres;

- a public footpath should be designated along the coastline to ensure public access by foot to and along the coastline.

Source: Ministry of the Environment. 1992. The Environment in Israel: National Report to UNCED. Ministry of the Environment, Jerusalem.

ANNEX VI

OBJECTIVES AND THEMATIC FRAMEWORK FOR THE MITIGATION OF SEISMIC RISK IN SEISMIC-PRONE AREAS

Objectives

The main objective of a national policy for the mitigation of seismic risk is to contribute to the reduction of loss of: lives, community identity, income and property (social, economic and environmental) frequently caused by earthquakes, and consequently to encourage a sustainable development, protection and enhancement of coastal zones.

Immediate objectives of such a policy are:

- to provide the basis for the formulation of appropriate national policies and programmes in seismic risk reduction, based on existing and available knowledge/experience;
- to develop multidisciplinary and comprehensive approaches in seismic risk research, assessment, and management;
- to introduce seismic risk reduction as an integral parts of physical planning and building;
- to strengthen and develop disaster preparedness;
- to create public awareness and a social consciousness of seismic risk in a realistic and practical sense.

Methodological framework

A general approach to seismic risk management can be explained through its methodological framework developed by MAP-PAP, accepted by several UN agencies - DHA/UNDRO including - and implemented in various projects. This framework includes the following components:

Hazard assessment (the scientific component):

- observation of seismic phenomena (instrumental networks and monitoring);
- seismological and seismotectonic studies/maps;
- seismic hazard assessment;
- seismic hazard mapping (macro and micro-zoning).

Vulnerability assessment (the engineering component):

- damage analysis;
- vulnerability assessment of structures and systems, including life-lines.

Risk reduction and management (the socio-economic component):

- a) Physical planning and building
 - comprehensive physical planning (regional and local);

- settlement planning, including land-use planning and detailed urban development planning;
 - aseismic building design and appropriate technologies;
 - design of earthquake scenarios for economic, social and physical planning and disaster preparedness;
 - revision of regional economic and development plans as a function of such scenarios.
- b) Legislation
- planning legislation for mitigation and reconstruction;
 - seismic building codes;
 - building regulations and controls;
 - codes for repair and strengthening.
- c) Planning, building and engineering aspects of disaster preparedness (emergency planning and management):
- rescue;
 - shelter and related services;
 - access and evacuation;
 - demolition and clearance.
- d) Public awareness of earthquake hazard, vulnerability and risk:
- public information and education;
 - simulation based on earthquake scenarios, with special reference to access, rescue and evacuation.

After heavy damaging earthquakes over the past 30-odd years a number of international and internationally funded national projects on seismic risk reduction have been carried out.

Within the UN system, the responsibility for seismic risk reduction lays on DHA/UNDRO-Geneva, while within the framework of UNEP, MAP/PAP has been implementing, since 1985, an action on seismic risk reduction in the Mediterranean.

ANNEX VII

ECONOMIC INSTRUMENTS

Economic instruments have always been used for implementing resource management policies, but in recent years they have found application also in environmental management, particularly in pollution control. The wider use of economic instruments developed for a number of reasons. Firstly, regulatory instruments were found insufficient, particularly in their role of promoting technical progress in clean technologies, or in new pollution control processes. Secondly, there was a disenchantment with the relative speed of their effectiveness. This was particularly the case with large bays and estuaries where the rehabilitation of ecosystems is particularly difficult and time consuming. Thirdly, regulatory instruments do not generate funds which would allow, for example, cross-subsidizing without contravening the Polluter Pays Principle.

One classification of economic instruments by the Organization for Economic Cooperation and Development (OECD) provides the following types:

- i) charges;
- ii) subsidies;
- iii) deposit-refund systems;
- iv) market creation; and
- v) financial enforcement incentives.

This classification refers only to environmental management and needs to be extended to cover resource management which is a vital component of coastal zone management.

Charges and Resource Pricing

Today a variety of charges are in use and they have different incentive (pollution reducing), revenue raising, resource use and redistributive effects. Normally, all these effects should be considered in the selection of the charges.

Effluent or pollution charges are imposed according to discharges into the environment and are based on the quantity and/or quality of pollutants released. Effluent charges can be imposed in all media: they are most widely used in the field of water pollution, but also for air, noise, and industrial waste. In the case of waste, these are imposed on private operators who treat or store waste, and thereby contribute to pollution. At least one country imposes a charge on surplus manure in order to mitigate the potential pollution effect of storing or otherwise disposing of surplus animal manure. Clearly, these charges are relevant to all activities also in coastal areas, and are presently used as a part of national pollution control policies in many countries.

User charges are probably the most widely used economic instruments both in pollution control and resource management. In pollution control they are applied as payments for the cost of collective public treatment of effluents and waste, for example for collection and disposal of solid waste. In resource management they are payments for the use of the resources, such as for irrigation water and for forest products.

User charges for pollution, for example for waste water, are applied both to households and firms and are based on volume of discharge, and sometimes also on pollution load. In many countries these charges are not regarded as economic instruments, that is, it is not thought that they have any incentive effect as far as pollution reduction is concerned, but as payment for services and as a tool for revenue raising to cover costs. However, experience suggests that they can have pollution reduction effects provided they are designed with this objective in mind, i.e. based on pollution load. Their use in coastal areas is crucial also for raising funds for pollution control.

User charges for resource management are also widely employed but often the "price-charge" is insufficient or totally fails to take certain services provided by the resource into account. It is important here to distinguish between charges paid for publicly provided resource services, for example piped water delivered to households and firms, and a lease of forest land or a sale of wetland with the permit to drain. Such differentiation is often not easy and is a combination of service charge and transfer of property rights with a permission to use for a specific purpose. They cover a wide range of services and resources: all types of water services, land for various uses (including the shore line and wetlands), coastal waters (including tidal land, coral reefs and off-shore islands), forests and forest services. Considerable progress has been made in recent years in developing natural resource pricing to include the environmental services provided by those resources, and a degree of international agreement has been reached. At the policy level, however, considerable divergences exist in the pricing policies of individual countries. These pricing policies are of considerable importance in coastal areas, from the point of view of both pollution control/conservation of resources, and revenue raising.

Product charges are charges laid upon the price of products which are polluting in the manufacturing or consumption phases, or of which a disposal system has been organized. Their use includes charges on various types of fuels, containers, pesticides, fertilizers, and on "feedstocks". Again the idea behind the scheme is partly to provide an incentive (to reduce the use of polluting substances) and/or to generate funds for pollution control, or environmental policies in general.

Administrative charges, of which there are many varieties (such as control and authorization fees), are payments for authority services; these include, for instance, registration fees for certain chemicals, or implementation and enforcement of regulations.

Tax differentiation is aimed at creating more favourable process for environmentally friendly products, or vice versa. Tax differentiation in practice is the same as negative or positive product charges.

Subsidies

Governments provide many types of financial assistance usually described with the general term "subsidies". Their objective is to assist polluters to undertake pollution control expenditures and the subsidy is usually tied to measures or performance. In principle, subsidies conform with the Polluter-Pays Principle, but they are widely used under the various exceptions foreseen by the Principle. The various types of subsidies are:

- *Grants* are straight out financial transfers of government funds to polluters; one particular variation on the subsidy scheme is "self-financing", where subsidies are paid from pollution charges to avoid the burden on the public purse and also to soften the burden of the charge on the polluting industry.
- *Soft loans* are repayable loans but provided under favourable conditions, such as below market rate of interest, or for long repayment period; in some countries, depending on the

tax system, firms prefer soft loans to grants, because grants are taxable, while interest payments are deductible.

- *Tax allowances* are given on expenditures for pollution control to reduce the cost impact of these expenditures of profit, and in this way, they have an incentive effect.
- Another type of financial assistance is provided by *undercharging of public services and prices of natural products*. These are, in fact, subsidies to pollute, particularly when they are applied to industry.

Deposit-refund system

These are used to impose a refundable charge on potentially polluting products. This system is particularly widely spread on drink and food containers and, in some countries, on car hulks. These systems are usually operated by private companies but helped by government regulations.

Market creation

Governments can create artificial markets to assist pollution control. Various alternatives are in operation:

Emissions trading can be regarded as a substitute for the use of pollution charges. Under this scheme, the discharger can sell his pollution "rights" if he is discharging less than his allowable discharges. The buyer then has the right to discharge more than his allowable discharge. These trades can take place within a plant, within a firm, or among different firms. Emissions trading is so far limited to very few countries and found few applications in the case of water resources, and hasn't so far been applied to non-point sources. Its greatest advantage appears to be in innovation in pollution control technology, in modernization, and in better industrial productivity.

Market intervention aims at creating or maintaining markets for residuals. This could again take various forms: freight discount provided for transporting waste material; stabilizing funds for waste paper prices; or assistance for a waste exchange market. Some of these are organized at municipal level.

Liability insurance is a recent development in the environment field and is used to establish legal liability of polluters for environmental damage, or clean-up costs associated with emission or storage of waste. Such liabilities create a market in insurance premiums. The incentive will be to lower the cost of the premiums through better industrial processes or fewer accidents.

Financial enforcement incentives

These are legal rather than economic instruments for potential or actual non-compliance with regulations.

Non-compliance fees are paid for failing to comply with regulations, and the charge is in accordance with the financial benefit gained through non-compliance.

Performance bonds are paid by potential "polluters" in expectation of compliance with the already imposed regulations. These payments are refunded when the regulations have been complied with.

Theoretical analysis and experience gained so far suggest that economic instruments provide a number of advantages when mixed with regulatory instruments:

- They can produce substantial cost savings, either by allowing polluters to select the most appropriate way of meeting standards, or equating the marginal cost of pollution control with emission charges;
- They offer an on-going incentive to reduce pollution below the level required by regulations; they encourage new technologies in pollution control and production processes;
- They provide flexibility; easy and fast to modify by the authorities and offer the polluter the freedom to choose;
- Together with resource pricing, they provide incentive for resource conservation;
- they provide a source of finance that can be used for specific environmental programmes.

Source: Juhasz, F. 1992. Economic Instruments and Tools for Coastal Zone Management Applicable in the Mediterranean Countries. PAP-4/1992/EM.1. UNEP/MAP/PAP, Split, Croatia.

BIBLIOGRAPHY

This is a bibliography of sources relevant for ICAM which were either used in this text or can be recommended to users for reference in the implementation of ICAM.

Chapter 1. Introduction

Lebel, G.H. and H. Kane: Sustainable Development. A Guide to Our Common Future. The Report of the World Commission on Environment and Development, Oxford University Press, Oxford, 1987.

UNCED (United Nations Conference on Environment and Development): Rio Declaration on Environment and Development, Rio de Janeiro, 1992.

Chapter 2. Justification for ICAM

Carter, R.W.G.: Coastal Environments. An Introduction to the Physical, Ecological and Cultural Systems of Coastlines, Academic Press, London, 1988.

Clark, J.: Coastal Ecosystem Management, Wiley/The Conservation Foundation, 1977.

Clark, J.: Integrated Management of Coastal Zones, FAO Technical Fisheries Paper 327, FAO Rome, Italy 1992

IOC/UNEP: Strategies for the Protection and Development of the Oceans and Coastal Areas (Unpublished), 1991.

OECD: Coastal Zone Management. Selected Case Studies, Organization for Economic Cooperation and Development. Paris, 1993.

Salm, R.V.: Marine and Coastal Protected Areas. A Guide for Planners and Managers. 2nd ed., IUCN, Gland, 1989.

Sorensen, J.C. and S.T. McCreary: Institutional Arrangements for Managing Coastal Resources and Environments, U.S. National Park Service and U.S. Agency for International Development, 1990.

The Conservation Foundation: Coastal Environmental Management Guidelines for Conservation of Resources and Protection against Storm Hazards, 1980.

UN/GESAMP: Marine Pollution Implications of Coastal Area Development. Reports and Studies. GESAMP No. 11, 1980.

UN/GESAMP: The State of the Marine Environment. Reports and Studies. GESAMP No. 39, 1990.

UNEP: Coordinated Mediterranean Pollution Monitoring and Research Programme (MED POL - PHASE I). Final Report 1975-1980. MAP Technical Reports Series No.9, UNEP, Athens, 1986

UNEP: State of the Mediterranean Marine Environment. MAP Technical Reports Series No. 28, UNEP, Athens, 1989.

UNEP: Common Measures Adopted by the Contracting Parties to the Convention for the Protection of the Mediterranean Sea Against Pollution. MAP Technical Reports Series No. 38, UNEP, Athens, 1990.

UNEP/UNESCO/FAO: Eutrophication in the Mediterranean Sea: Receiving Capacity and Monitoring of Long-Term Effects. MAP Technical Reports Series No.21, UNEP, Athens, 1988.

UNEP/WMO: Airborne Pollution of the Mediterranean Sea. Report and Proceedings of a WMO/UNEP Workshop. MAP Technical Reports Series No. 31, UNEP, Athens, 1989.

World Resources Institute: World Resources 1986-87, Basic Books, New York, USA, 1987.

World Resources Institute: World Resources 1992-93, Oxford University Press, Oxford, UK, 1992.

Chapter 3. The Development and Implementation of ICAM

California Coastal Zone Conservation Commissions: California Coastal Plan, California Coastal Zone Conservation Commission, San Francisco, USA, 1975.

Chua, T.E. and L.F.Scura (eds.): Integrative Framework and Methods for Coastal Area Management, ICLARM, Manila, 1992

Goudie, A.: The Human Impact on the Natural Environment. Third Edition, Basil Blackwell, Oxford, UK, 1990.

Hufschmidt, M.M. *et al.*: Environment, Natural Systems and Development. An Economic Valuation Guide, The Johns Hopkins University Press, Baltimore, USA, 1983.

Koudstaal, R.: Water Quality Management Plan North Sea. Framework for Analysis, A.A. Balkema, Rotterdam, The Netherlands, 1987.

Lang, R. (ed.): Integrated Approaches to Resource Planning and Management, The University of Calgary Press, Calgary, Canada, 1986.

McHarg, I.L.: Design with Nature. John Wiley, New York, USA, 1992.

Mitchell, B.: Geography and Resource Analysis. Second Edition, Longman, Harlow, UK, 1989.

OECD: Coastal Zone Management. Integrated Policies, Organization for Economic Cooperation and Development. Paris, France, 1993.

PAP/RAC: A Common Methodological Framework for Integrated Planning and Management in Mediterranean Coastal Areas, UNEP/MAP/PAP, Split, Croatia, 1988.

Penning-Rowsell, E. *et al.*, The Economics of Coastal Management. A Manual of Benefit Assessment Techniques, Belhaven Press, London, 1992

Rees, J.: Natural Resources. Allocation, Economics and Policy. Second Edition. Routledge, London, UK, 1990.

Snedaker, S.C. and C.D. Getter: Coastal Resources Management Guidelines, U.S. Department of the Interior / National Park Service and U.S. Agency for International Development, 1985.

Chapter 4. Tools and Techniques for ICAM

4.1 Data Base Management

Burrough, P.A.: Principles of Geographic Information Systems for Land Resources Assessment, Clarendon, Oxford, 1986.

- Date, C.J.: *An Introduction to Database Systems. Volume II*, Addison-Wesley, Reading, Massachusetts, 1985.
- Fedra, K. *et al*: *Expert Systems for Environmental Screening. An Application in the Lower Mekong Basin*, IIASA, Laxenburg, Austria, 1991.
- Laurini, R. and D. Thompson: *Fundamentals of Spatial Information Systems. The A.P.I.C. Series, Number 37*, Academic Press, Harcourt Brace Jovanovich, London, 1991.
- Reitsma, R.F.: *Functional Classification of Space-Aspects of Site Suitability in a Decision Support Environment*, IIASA, Laxenburg, Austria, 1990.
- Star, J. and J.E. Estes: *Geographic Information Systems*, Prentice Hall, Englewood Cliffs, New Jersey, 1990.
- Ulman, J.D.: *Principles of Database Systems*, Computer Science Press, Rockville, Maryland, 1982.

4.2 Evaluation and Assessment Techniques

a) Environmental Impact Assessment

- EC: The EC Directive on "The Assessment of the Effects of Certain Public and Private Projects on the Environment" (87/337/EEC).
- Hopkins, J.D. *et al*: *Environmental Impact Statements. A Handbook for Writers and Reviewers*. University of Illinois, Urbana Champaign, Illinois, 1973.
- Jain, R.K., L.W. Urban and G.S. Stacey: *Environmental Impact Analysis. A New Dimension in Decision Making*, Van Nostrand Reinhold, London, 1977.
- OECD: *Environmental Impact Analysis of Environmental Consequences of Significant Public and Private Projects*. Organization for Economic Cooperation and Development, Paris, 1979.
- Tortlage, C.A: *Environmental Assessment. A Practical Guide*, Gower Publishing Company, Aldershot, UK, 1990.
- Turnbull, Robert G.K (ed.): *Environmental and Health Impact Assessment of Development Projects. A Handbook for Practitioners*, Elsevier Applied Science, London, 1992.
- UNEP: *An Approach to Environmental Impact Assessment for Projects Affecting the Coastal and Marine Environment*. UNEP Regional Seas Reports and Studies No. 122, UNEP, 1990.
- UNEP: *Environmental Impact Assessment. Marina in Paphos*. UNEP Regional Seas Reports and Studies No. 130, UNEP, 1990.
- UNEP/MAP/PAP: *Environmental Impact Assessment of the Rhodes Wastewater Treatment Plant (CAMP/1991-1992/GR/EIA.1)*, PAP/RAC, Split, Croatia, 1993.
- Westman, Walter E: *Ecology, Impact Assessment and Environmental Planning*, John Wiley and Sons, New York, 1985.

b) Carrying Capacity Assessment

- UN/GESAMP: *Environmental Capacity. An Approach to Marine Pollution Prevention, Reports and Studies*. GESAMP No. 30, 1988.
- UNEP/MAP/PAP: *Methodological Framework for Assessing Tourism Carrying Capacity in Mediterranean Coastal Zones (PAP-9/P-1)*, PAP/RAC, Split, Croatia, 1990.
- UNEP/MAP/PAP: *Carrying Capacity Assessment for Tourism Activities in the Island of Vis (PAP-9-CC-1)*, PAP/RAC, Split, Croatia, 1991.

UNEP/MAP/PAP: Carrying Capacity Assessment for Tourism Activities in the Central-Eastern Part of the Island of Rhodes (CAMP/1991- 1992/GR/CC.1), PAP/RAC, Split, Croatia, 1993.

c) Climatic Change

Arrhenius E. and T.W. Waltz.: The Greenhouse Effect. Implications for Economic Development, W.B. Discussion Papers No. 78, World Bank, 1990.

Houghton, J.T., G.J. Jenkins and J.J. Ephraumus (eds.): Climate Change. The IPCC Impact Assessment, Report Prepared for IPCC by Working Group I, Cambridge University Press, Cambridge, 1991.

Jeftic, L., J.D. Milliman and G. Sestini (eds.): Climatic Change and the Mediterranean. Environmental and Societal Impacts of Climate Change and Sea-Level Rise in the Mediterranean Region, E. Arnold, London, 1992.

Pernetta, J.C. and D. Elder: Climate, Sea-Level Rise and the Coastal Zone. Management and Planning for Global Changes, IUCN, Gland, 1990.

UNEP: Report of the Joint Meeting of the Task Team on Implications of Climatic Changes in the Mediterranean and the Coordination of the Task Teams for the Caribbean, South East Pacific, South Pacific, East Asian Seas and South Asian Seas Region, UNEP(OCA)/WG.2/25, Split 1988, UNEP, 1988.

WMO/UNEP Intergovernmental Panel on Climate Change: Strategies for Adaptation to Sea - Level Rise, Response Strategies Working Group, 1990.

d) Seismic Risk Mitigation

Coburn, A. and R. Spence: Earthquake Protection, John Wiley and Sons, Chichester, 1992.

UNDR0: Disaster Prevention and Mitigation. A Compendium of Current Knowledge. United Nations Disaster Relief Organization. Geneva, Switzerland, 1987.

e) Technological Hazards

American Institute of Chemical Engineers: Guidelines for Hazard Evaluation Procedures, AIChE Centre for Chemical Process Safety, New York, USA, 1985.

Commission of European Communities: Directive of 24 June 1982 on the Major Accidents Hazards of Certain Industrial Activities, Publ. No. 230/1, Brussels, 1982.

UNEP/IE-PAC(a): APELL. A Process for Responding to Technological Accidents (E.88.III.D.3), UNEP Industry and Environment Programme Activity Centre, Paris, 1988.

UNEP/IE-PAC(b): APELL. Awareness and Preparedness for Responding to Technological Accidents, UNEP Industry and Environment Programme Activity Centre, Paris, 1988.

UNEP/IE-PAC: Hazard Identification and Evaluation in a Local Community. Technical Report No.12, UNEP/Industry and Environment Programme Activity Centre, Paris, 1992.

f) Oil Spills Control

CONCAWE: A Field Guide to Coastal and Oil Spill Control and Clean-up Techniques. Report No. 9/81, Conservation of Clean Air and Water in Europe. The Hague, The Netherlands, 1981.

IMO: Manual on Oil Pollution. Section II (Contingency Planning), IMO, London, UK, 1988.

International Tanker Owners Pollution Federation: Response to Marine Oil Spills, Witherby, London, UK, 1987.

IPIECA: A Guide to Contingency Planning for Oil Spills on Water, International Petroleum Industry Environmental Conservation Association. London, UK, 1991.

g) Economic Evaluation Techniques

Barde, J.P. and D. Pearce (eds.): Valuing the Environment, Earthscan Publications, London, 1991.

Dasgupta, A.K. and D. Pearce: Cost-Benefit Analysis. Theory and Practice, Macmillan, 1972.

UNEP: Costs and Benefits of Measures for the Reduction of Degradation of the Environment from Land-Based Sources of Pollution in Coastal Areas. MAP Technical Reports Series No. 72, UNEP, Athens, 1993.

h) Prospective Studies

Grenon, M. and Batisse, M. (eds.): The Blue Plan. Futures for the Mediterranean Basin, Oxford University Press, Oxford, UK, 1989.

UNEP/MAP/BP: The Blue Plan. Executive Summary and Suggestions for Action, BP/RAC, Sophia Antipolis, France, 1988.

UNEP/MAP/BP: Prospective Study on the Iskenderun Area, Turkey, BP/RAC, Sophia Antipolis, France, 1993.

UNEP/MAP/PAP: Management of Natural Resources of the Kastela Bay: Development-Environment Scenarios, PAP/RAC, Split, Croatia, 1992.

4.3 Instruments for Implementation

a) Economic instruments

OECD: Improving the Enforcement of Environmental Policy, Organization for Economic Cooperation and Development. Paris, 1986.

OECD: Economic Instruments for Environmental Protection, Organization for Economic Cooperation and Development. Paris, 1989.

OECD: Environment Policy. How to Apply Economic Instruments, Organization for Economic Cooperation and Development. Paris, 1991.

b) Conflict Resolution

Dorcey, A.H.J.: Negotiation in the Integration of Environmental and Economic Assessment for Sustainable Development. Paper presented at the Workshop on Integrating Economic and Environmental Assessment, 17-18 November 1988, Vancouver, B.C., 1988.

Fisher, R. and W. Ury: Getting to Yes. Negotiating Agreement Without Giving In, Houghton Mifflin Co., Boston, MA, 1981.

Issued and printed by



Oceans and Coastal Areas Programme Activity Centre
United Nations Environment Programme

Additional copies of this publication
may be obtained from:

Oceans and Coastal Areas Programme Activity Centre
United Nations Environment Programme
P. O. Box 30552
Nairobi
Kenya